

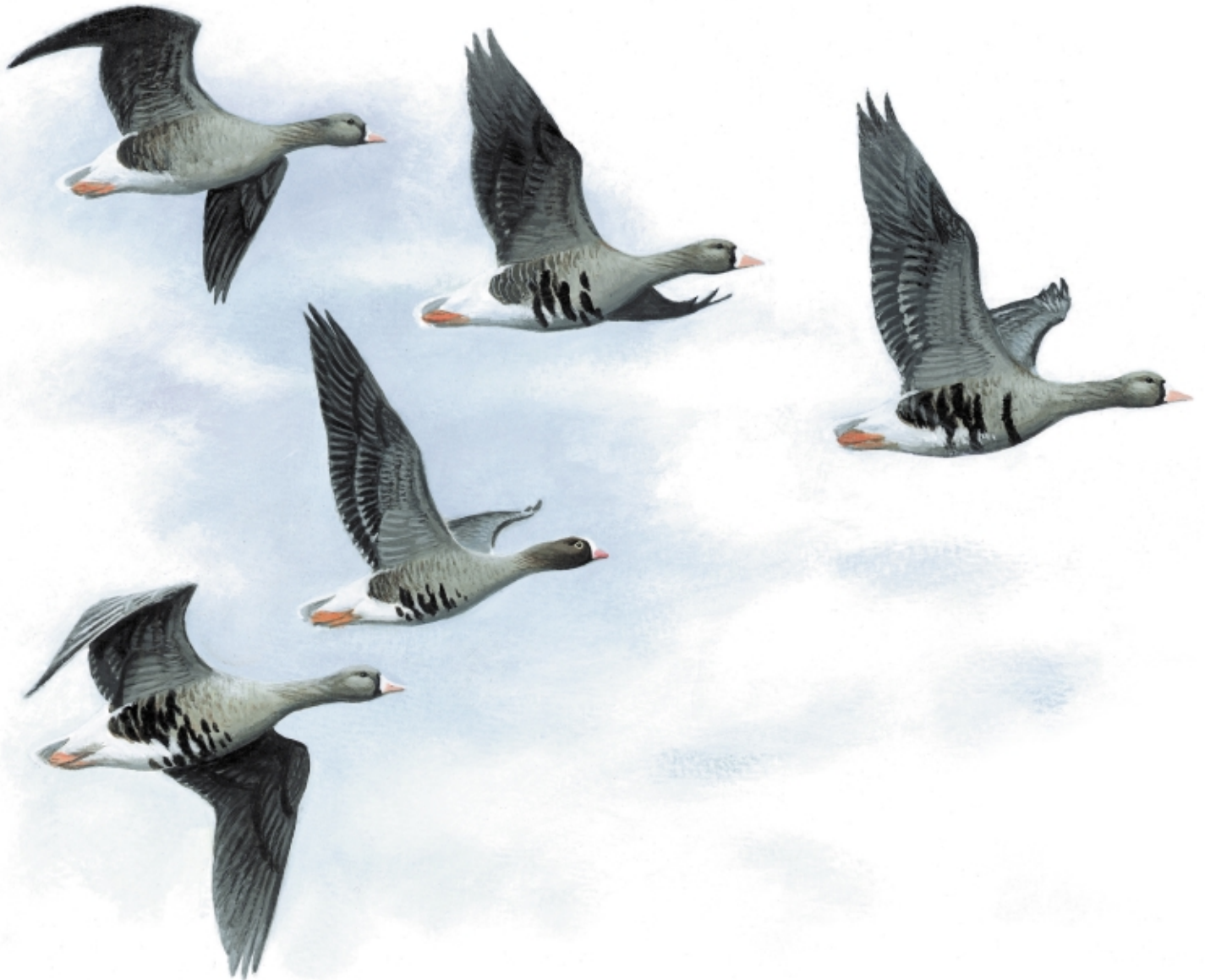

WWF Finland Report No 12
NOF Rapportserie Report No 1-2000

Fennoscandian Lesser White-fronted Goose conservation project Annual report 1999



Edited by
Petteri Tolvanen, Ingar Jostein Øien and Kalle Ruokolainen



Introduction

Petteri Tolvanen
Juha Markkola
Ingar Jostein Øien
Tomas Aarvak

The Lesser White-fronted Goose (*Anser erythropus*, later LWfG) is a globally endangered species (Tucker & Heath 1994, Tolvanen et al. 1999), and at present the only threatened arctic goose species in the Palearctic region. The current estimate of the world population in mid-winter is 25,000–30,000 individuals (Tolvanen et al. 1999), of which normally approximately 20–40% are juveniles (see e.g. Tolvanen et al. 2000, pp. 43–50 in this report; Markkola et al. 2000, pp. 9–15 in this report).

Hunting in the wintering grounds, on migration and also in the breeding grounds has proved to be the main threat to the LWfG populations. In addition, also other significant threats like decrease and deterioration of wintering and staging habitats, human disturbance and increased depredation by e.g. Red Fox (*Vulpes vulpes*) exist locally. Based on ring recoveries and satellite tracking data, it has become clear that the high hunting pressure alone is sufficient to explain the continuous decline of the LWfG populations. Spring hunting of adult birds, which is still very common in most of the LWfG breeding range in Russia in the staging and breeding areas has especially harmful effects on the population. In China, where the LWfG leave the wintering grounds as late as in early April, the winter hunting pressure from poachers using poison is especially harmful to the eastern populations.

The LWfG world population can roughly be divided into two parts of equal size between the western and eastern flyway populations (Lorentsen et al. 1999). The western flyway consists of populations that breed in scattered patches in an area stretching from Fennoscandia to Taimyr Peninsula (see e.g. Morozov 2000, pp. 35–38 in this report), and migrate through north-western Kazakstan (see e.g. Tolvanen et al. 2000, pp. 43–50 in this report) to the still mainly unknown wintering areas somewhere in the Caspian Sea – Black Sea region. Approximately 1,100 LWfG were found in Azerbaijan in January–February 1996 (Aarvak et al. 1996), 440 individuals were reported in Turkmenistan in the winter 1998–1999 (see Markkola 2000b, p. 57 in this report), and recent observations indicate that considerable amounts of LWfG could be wintering in the border area between Uzbekistan, Turkmenistan, Afghanistan and Tadjikistan (see Markkola 2000a, p. 57 in this report), and in the Crimea region in Ukraine (Kondratyev et al. 2000, p. 60 in this report). However, the wintering

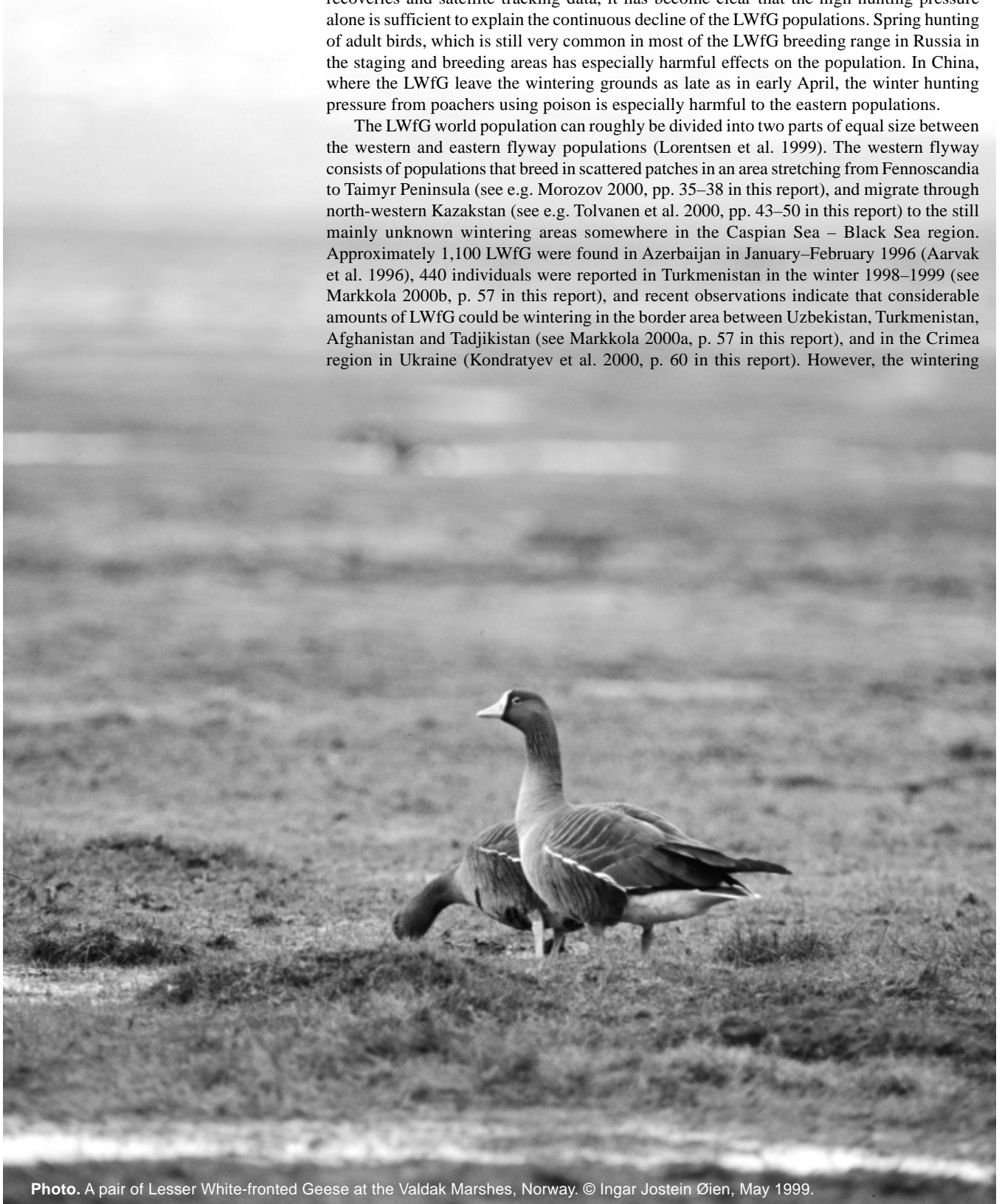

Photo. A pair of Lesser White-fronted Geese at the Valdak Marshes, Norway. © Ingar Jostein Øien, May 1999.



Photo. Aggressive interactions between pairs of Lesser White-fronted Geese are frequent in the spring staging grounds in Fennoscandia, where the behaviour of LWfG has been studied for several years. In the wintering grounds in China conflicts between individuals were not registered at all during the time budget studies at East Dongting Lake in February 1999. © Ingar Jostein Øien, Valdak Marshes, May 1999.

grounds of the main part of the western populations remain unknown.

A minor part – apparently not more than a few hundreds – of the western flyway birds migrate via Poland, Germany and Hungary (see e.g. Lorentsen et al. 1998, 1999) to Greece and Turkey for wintering. Out of these, less than 100 individuals presently winter in Greece (see e.g. Lampila 1998, Kazantzidis & Nazirides 1999). Approximately half of the highly endangered Fennoscandian breeding population use this flyway.

The eastern flyway populations, breeding in central and eastern Siberia, from the Taimyr Peninsula eastwards, migrate to winter mainly in south-eastern China. Contrary to the situation for the western populations, the wintering areas of the eastern populations are better known than the breeding areas. Important wintering areas have been revealed during the 1990's in China, where the East Dongting Lake being clearly the most important place at the present knowledge (see Markkola et al. 2000, pp. 9–15 in this report; Lei Gang 2000, pp. 16–17 in this report). Most of the breeding areas of the eastern populations are poorly known, but gratifyingly, an important breeding area was localised in the Indigirka River area in Yakutia during summer 1999 (Syroechkovski Jr. 2000, pp. 39–40 in this report).

As a result of genetic studies on LWfG in recent years (see e.g. Ruokonen & Lumme 1999, Ruokonen 2000, pp. 54–56 in this report), it has become clear that the western and eastern populations of LWfG are also genetically distinct. In addition, the genetic composition of the Fennoscandian population suggests restrictions to the gene flow with other breeding populations. Therefore, it should be conserved as a separate unit. The genetic studies have also revealed, that the captive LWfG population formerly used for reintroduction in Finland – and which is still used in Sweden – is a mixture of western and eastern mitochondrial haplotypes, and approximately 25% of the studied captive LWfG carried the mitochondrial DNA of White-fronted Goose (*Anser albifrons*). Therefore, the Finnish Ministry of the Environment and the LWfG project of WWF Finland decided to stop reintroduction in Finland using the current captive stock.

The final goal for the LWfG conservation work is recovery of the world population and all remaining subpopulations to a sustainable level. In Fennoscandia, a viable population size would be at least some hundred breeding pairs, while the current population size is only 30–50 pairs. Still, the main problem in the conservation work for the western LWfG populations – of which the Fennoscandian population is the most endangered at the moment – is the lack of knowledge about the most important staging and wintering areas south of the staging area in Kazakstan. Therefore, the main priority of the Fennoscandian LWfG conservation project is to localise and subsequently to implement conservation measures in the most important sites. As a result of our satellite tracking and ringing programmes, a very important staging area is already revealed in north-western Kazakstan, and projects aiming at conserving the most important wetlands are already under way. In the Kanin Peninsula in north-western Russia, where a stop-over site especially important for the Fennoscandian population was localised in 1995 by satellite tracking, a protected area (Shoininsky Zakasnik)



Photo. Risto Karvonen toasting for a brighter future for the Lesser White-fronted Goose in the opening of the Lesser White-fronted Goose exhibition in the Sami Museum Siida in Inari, November 1999 © Maija Aalto, November 1999

was established in 1997 (Luukkonen & Tolvanen 1996, Prokosch 1997).

Throughout the 1990's, the Finnish and Norwegian LWfG working groups, together with colleagues from e.g. Russia and Kazakstan, have put increasingly more effort in the research and conservation of the main population, breeding in central Siberia. At the same time, the Finnish and Norwegian groups united their efforts in general. In Russia and the former Soviet Union, the Goose and Swan Study Group of Eastern Europe and North Asia (RGG) has been the main co-operation partner of the Fennoscandian project. The international LWfG Task Force was established in 1995 as part of the Goose Specialist Group of Wetlands International. The Task Force co-ordinates the conservation and research work of the national projects, and makes priorities for the future conservation efforts through an annually updated Urgent Action Plan, based on the international Action Plan (Madsen 1996), and the most recent knowledge.

In this second joint annual report of the Fennoscandian LWfG conservation project, the main results of the LWfG monitoring and conservation work in 1999 by the Fennoscandian project are presented, and in addition, a progress report of the Swedish reintroduction programme is included.



Photo. Jyrki Pynnönen surveying the breeding grounds of Lesser White-fronted Geese in northern Finnish Lapland.
© Petteri Tolvanen, June 1993

The Fennoscandian LWfG conservation project

LWfG is ranked in the highest category in the national Red Lists in Finland, Norway and Sweden. The Finnish working group for LWfG was formed by WWF Finland in 1983. Since then, the Finnish LWfG project has e.g. monitored the staging geese during migration, made extensive surveys in Finnish, Swedish and Norwegian Lapland and carried out research work on the biology of LWfG. The LWfG project of WWF Finland has an official status as an adviser of the Ministry of the Environment Finland concerning conservation of the LWfG. In Norway, the Norwegian Ornithological Society NOF (the Norwegian partner of BirdLife International) has run the Lesser White-fronted Goose Monitoring Programme since 1987. The first years were mainly spent on mapping of breeding and staging areas as well as studies on the reasons for the population decline in Norway. Later on, annual spring and autumn monitoring of the most important staging ground, the Valdak Marshes, has been established. The need for information about the situation along the migration route and in the wintering areas lead to the implementation of satellite tracking, which has, together with the establishment of the international LWfG Task Force, put the monitoring work in Fennoscandia into a global perspective. Information about the alarming situation for the LWfG has been distributed to management authorities, organisations and journals dealing with ornithology, hunting and conservation in Europe and north-western Asia.

Internet pages about LWfG conservation issues and results from the Fennoscandian LWfG project can be viewed at: <http://www.metsa.fi/natural/projects/lwfg/index.htm> (in English); <http://www.metsa.fi/luo/projektit/kiljuh/index.htm> (in Finnish); <http://www.museumsnett.no/stabbursnes/trekk/htm> (in Norwegian) and <http://www.birdlife.no> (in English and Norwegian).

Acknowledgements

The work presented in this publication has been financed by the Finnish LWfG Life project, the Finnish Ministry of Environment, the Norwegian Directorate for Nature Management (DN), Office of the County Governor of Finnmark, Environmental Department and the Norwegian Ornithological Society (NOF). In the years 1997–1999, the major part of the LWfG conservation activities in Finland were carried out by the Finnish LWfG Life-Nature project supported by European Union (EU). The partners of the LWfG Life project Finland are listed in appendix A. In addition to these, several other organisations and private persons have supported the work in many ways. We are also indebted to all the co-operating organisations and partners listed in Appendix A. Several persons have helped in the editorial work, especially Sami Timonen, Petro Pynnönen and Mikko Pitkänen. Special thanks to Jyrki Heimonen and Petri Kuokka (Aarnipaja ky) for help in the layout work, and to Jari Kostet for allowing us to use his excellent LWfG paintings in this report.

References

- Aarvak, T., Øien, I.J. & Nagy, S. 1996:** The Lesser White-fronted Goose Monitoring programme. Annual report 1996. – Norwegian Ornithological Society, NOF Rapportserie. Report No 7-1996.
- Kazantzidis, S. & Nazirides, T. 1999:** National Action Plan for the Lesser White-fronted Goose (*Anser erythropus* Linnaeus, 1758). – WWF Greece. Hellenic Ornithological Society, Society for the Protection of Prespa. Thessaloniki. 36 pp.
- Kondratyev, A.V., Buzun, V.A. & Grinchenko, A. 2000:** New wintering area for Lesser White-fronted Geese in Crimea Peninsula, Ukraine. In: Tolvanen, P., Øien, I.J. & Ruokolainen, K. (eds.): Fennoscandian Lesser White-fronted Goose Conservation Project. Annual report 1999. – WWF Finland Report 12 & Norwegian Ornithological Society,

- NOF Rapportserie Report no. 1-2000:60.
- Lampila, P. 1998:** Monitoring of wintering Lesser White-fronted Geese *Anser erythropus* in north-eastern Greece, 8 January-8 April 1997. In: Tolvanen, P., Ruokolainen, K., Markkola, J., & Karvonen, R. 1998 (eds.): Finnish Lesser White-fronted Goose Conservation Project. Annual report 1997. WWF Finland Report no 9:7-8.
- Lei, G. 2000:** Status of Lesser White-fronted Goose in China. In: Tolvanen, P., Øien, I.J. & Ruokolainen, K. (eds.): Fennoscandian Lesser White-fronted Goose Conservation Project. Annual report 1999. – WWF Finland Report 12 & Norwegian Ornithological Society, NOF Rapportserie Report no. 1-2000:16-17.
- Lorentsen, S.-H., Øien, I.J., Aarvak, T., Markkola, J., von Essen, L., Farago, S., Morozov, V., Syroechkovsky Jr., E. E. & Tolvanen, P. 1999:** Lesser White-fronted Goose *Anser erythropus*. – In: Madsen, J., Cracknell, G. & Fox, A.D. (eds.): Goose populations of the Western Palearctic. A review of status and distribution. Wetlands International Publ. No. 48, Wetlands International, Wageningen, The Netherlands. National Environmental Research Institute, Rønde, Denmark. Pp. 144-161.
- Lorentsen, S.-H., Øien, I. J. & Aarvak, T. 1998:** Migration of Fennoscandian Lesser White-fronted Geese *Anser erythropus* mapped by satellite telemetry. – *Biological Conservation* 84:47-52.
- Luukkonen, J. & Tolvanen, P. 1996:** Species and spaces protection join forces. Lesser White-fronted Goose (*Anser erythropus*) expedition to the Kanin Peninsula in August-September 1996. – *WWF Arctic Bulletin* 1996(4):21.
- Madsen, J. (compiler) 1996:** International action plan for the Lesser White-fronted Goose (*Anser erythropus*). In: Heredia, B., Rose, L. & Painter, M. (eds.): Globally threatened birds in Europe. Action plans. – Council of Europe Publishing, BirdLife International.
- Markkola, J. 2000a:** New information about wintering Lesser White-fronted Geese in Uzbekistan. In: Tolvanen, P., Øien, I.J. & Ruokolainen, K. (eds.): Fennoscandian Lesser White-fronted Goose Conservation Project. Annual report 1999. – WWF Finland Report 12 & Norwegian Ornithological Society, NOF Rapportserie Report no. 1-2000:57.
- Markkola, J. 2000b:** Lesser White-fronted Goose protected in Turkmenia. In: Tolvanen, P., Øien, I.J. & Ruokolainen, K. (eds.): Fennoscandian Lesser White-fronted Goose Conservation Project. Annual report 1999. – WWF Finland Report 12 & Norwegian Ornithological Society, NOF Rapportserie Report no. 1-2000:57.
- Markkola, J., Iwabuchi, S., Lei Gang, Aarvak, T., Tolvanen, P. & Øien, I.J. 2000:** Lesser White-Fronted Goose survey at the East Dongting and Poyang lakes in China, February 1999. In: Tolvanen, P., Øien, I.J. & Ruokolainen, K. (eds.): Fennoscandian Lesser White-fronted Goose Conservation Project. Annual report 1999. – WWF Finland Report 12 & Norwegian Ornithological Society, NOF Rapportserie Report no. 1-2000:9-15.
- Morozov, V. 2000:** Surveys for Lesser White-fronted Goose in the Bolshezemelskaya Tundra, European Russia, in 1999. In: Tolvanen, P., Øien, I.J. & Ruokolainen, K. (eds.): Fennoscandian Lesser White-fronted Goose Conservation Project. Annual report 1999. – WWF Finland Report 12 & Norwegian Ornithological Society, NOF Rapportserie Report no. 1-2000:35-38.
- Prokosch, P. 1997:** Detected by satellite and protected within 16 months: Shoininski Reserve established on Kanin. – *WWF Arctic Bulletin* 1997(1):16.
- Ruokonen, M. & Lumme, J. 1999:** Phylogeography and population genetic structure of the Lesser White-fronted Goose. In: Tolvanen, P., Øien, I.J. & Ruokolainen, K. (eds.): Fennoscandian Lesser White-fronted Goose Conservation Project. Annual report 1998. – WWF Finland Report 10 & Norwegian Ornithological Society, NOF Rapportserie Report no. 1-1999:51-52.
- Ruokonen, M. 2000:** Genetic composition of the captive Lesser White-fronted Goose population In: Tolvanen, P., Øien, I.J. & Ruokolainen, K. (eds.): Fennoscandian Lesser White-fronted Goose Conservation Project. Annual report 1999. – WWF Finland Report 12 & Norwegian Ornithological Society, NOF Rapportserie report no. 1-2000:54-56.
- Syroechkovski, E. E. Jr. 2000:** New breeding and moulting areas of Lesser White-fronted Goose revealed in Indigirka, Yakutia. In: Tolvanen, P., Øien, I.J. & Ruokolainen, K. (eds.): Fennoscandian Lesser White-fronted Goose Conservation Project. Annual report 1999. – WWF Finland Report 12 & Norwegian Ornithological Society, NOF Rapportserie Report no. 1-2000:39-40.
- Tolvanen, P., Markkola, J., Aarvak, T. & Øien, I. J. 1999:** Introduction. In: Tolvanen, P., Øien, I.J. & Ruokolainen, K. (eds.): Fennoscandian Lesser White-fronted Goose Conservation Project. Annual report 1998. – WWF Finland Report 10 & Norwegian Ornithological Society, NOF Rapportserie Report no. 1-1999:5-8.
- Tolvanen, P., Eskelin, T., Aarvak, T., Eichhorn, G., Øien, I. J. & Gurtovaya, E. 2000:** Monitoring the autumn staging of Lesser White-fronted Geese in Kazakhstan, October 1999. In: Tolvanen, P., Øien, I.J. & Ruokolainen, K. (eds.): Fennoscandian Lesser White-fronted Goose Conservation Project. Annual report 1999. – WWF Finland Report 12 & Norwegian Ornithological Society, NOF Rapportserie report no. 1-2000:43-50.
- Tucker, G. & Heath, M.F. 1994:** Birds in Europe: their conservation status. – BirdLife Conservation Series no. 3. BirdLife International. Cambridge.



Photo. A juvenile (feeding) and an adult Lesser White-fronted Goose at the autumn staging site on the island of Skjåholmen, Varangerfjord, northern Norway © Petteri Tolvanen, August 1999

Authors' addresses

– PT: WWF Finland, Lintulahdenkatu 10, FIN-00500 Helsinki, FINLAND, e-mail: tolvanen@sl.fi

– JM: North Ostrobothnia Regional Environment Centre, P.O. Box 124, FIN-90101 Oulu, FINLAND, e-mail: juha.markkola@vyh.fi

– IJØ & TAA: Norwegian Ornithological Society (NOF), Seminarplassen 5, N-7540 Klæbu, NORWAY, e-mails: ingar@birdlife.no, tomas@birdlife.no

Lesser White-fronted Goose survey at the East Dongting and Poyang lakes in China, February 1999

Juha Markkola¹, Shigeki Iwabuchi², Lei Gang³, Tomas Aarvak⁴, Petteri Tolvanen⁵ & Ingar Jostein Øien⁴

¹ North Ostrobothnia Regional Environment Centre, P.O. Box 124, FIN-90101 Oulu, FINLAND, e-mail: juha.markkola@vyh.fi

² Sendai Science Museum, 4-1 Dainohara Forest Park, Aoba Ward, Sendai, JAPAN 981, e-mail: iwabuchi@sendai-smus.go.jp

³ East Dongting Lake National Nature Reserve, Yueyang City, Hunan Province, 414000, P.R. of CHINA

⁴ Norwegian Ornithological Society (NOF), Seminarplassen 5, N-7540 Klæbu, NORWAY, e-mails: tomas@birdlife.no, ingar@birdlife.no

⁵ WWF Finland, Lintulahdenkatu 10, FIN-00500 Helsinki, FINLAND, e-mail: tolvanen@sll.fi

1. Introduction

The unique importance of China as the main wintering quarter for the eastern populations of the Lesser White-fronted Goose (*Anser erythropus*, later LWfG) was unknown until 1994, when Jian Jian Lu presented annual counts of 1,000–10,000 LWfG from China at the Anatidae 2000 conference in Strasbourg, France (see Anonymous 1995). However, this information was presented in several articles in Chinese already in the years 1990–1994 (Lu 1990, Hu & Guan 1994, Li et al. 1994, Liu 1994, Liu et al. 1994, Lu and the Waterbird Specialist Group of the Chinese Ornithological Association 1994; see Table 1). Lu and the articles mentioned above listed 10 places, where 50 or more LWfG had been observed and of these the eight most important are listed on Table 1.

During the period 31 January – 15 February, 1999, after the Wetlands International Goose Specialist Group meeting in Matsushima, Japan, representatives of the Wetlands International LWfG Task Force visited China in order to survey the East Dongting Lake area (Hunan province) and Lake Poyang (Jiangxi province). These sites are supposed to be the two most important wintering places for the eastern flyway population of the LWfG. The aim of the survey was to estimate the numbers and distribution of LWfG at these two well known goose wintering quarters, to collect demographic data, to calibrate the census techniques between European, Chinese and Japanese colleagues as well as to negotiate with Chinese goose specialists and authorities about improving the conservation of the LWfG in these areas.

Of the sites (cf. Table 1), East Dongting Lake is classified mainly as a wintering area, Qingdao mainly as a staging area and Xingkai as a pure staging area. The lakes 1, 2, 3, 6 (Figure 1a) and Shenjing Lake, all belong more or less to the Chang Jiang (Yangtze) river system. The distance between the East Dongting Lake Goose Station and the administration centre of Poyang Lake Nature Reserve was measured at 311 km.

All the areas listed in Table 1, except Xinkai (Hanka) Lake and maybe Huang He are located in climatic zones that provide suitable wintering conditions for LWfG. However, it is not clear to what extent LWfG visit several of these sites, thus resulting in overlapping counts, or that some flocks could be missed. Synchronous counts in this huge country are difficult to implement, and a reliable estimation of

the total numbers of wintering or staging LWfG in China can still not be made.

From the numbers presented (Table 1), the East Dongting Lake did not seem to be a place of special importance for LWfG. However, as part of a co-operation project between the Forest and Park Service of Finland and the corresponding Chinese organisation in Hunan, a Chinese-Finnish research group visited the East Dongting Lake in January 1996, and registered 2,000–3,000 LWfG (Below & Virolainen 1996). In February 1997, a joint Chinese-Japanese group counted a total of 13,700 LWfG at East Dongting Lake National Nature Reserve (Iwabuchi et al. 1997). This number exceeds the figures counted anywhere else along the western or eastern flyway of the LWfG, and represented roughly 60 % of the assessed world population at that moment.

In the period 16–28 February 1998, Japanese goose researchers and the staff of East Dongting Lake National Nature Reserve organised a training camp for goose identification and survey methods (Iwabuchi et al. 1998). Probably due to difficult weather conditions (constant smog), less LWfG were counted as compared with the previous year. However, pure flocks of 340, 95 and probably 914 (only LWfG voices heard from the flock) LWfG were observed in addition to 1,260 unidentified geese.

2. Itinerary, study areas and weather conditions

The itinerary of the survey is shown in Table 2. In general we had good weather conditions during the survey, with some minor problems caused by smog limiting the visibility.

2.1. East Dongting Lake

The East Dongting Lake is a part of the huge Dongting Lake system, consisting of West, South and East Dongting Lake (Figure 1b). This area covers altogether c. 4,000 km². East Dongting Lake is a nature reserve covering an area of c. 1,190 km². The fluctuations in water-level are huge, with as much as 15 m difference between the low water level in winter, and the spring and, especially summer monsoon floods.

During winter, c. 290 km² of the area is covered by water, and c. 200 km² by reedbeds, which are mostly harvested by reed-farms.

Table 1. The most important sites in China where 50 or more Lesser White-fronted Geese have been observed (see Figure 1).

Locality	Province	Coordinates	Count	Date	Reference
Poyang Lake	Jianxi	28°50'N, 116°10'E	5,432	16 Jan, 1990	Lei 1999
Poyang Lake	Jianxi	28°50'N, 116°10'E	3,100	21 Nov, 1991	Lei 1999
Poyang Lake	Jianxi	28°50'N, 116°10'E	9,790	winter 1988–89	Lei 1999
Shijiu Lake	Jiangsu & Anhui	31°20'N, 118°40'E	2,650	20 Feb, 1992	Anonymous 1995
East Dongting Lake	Hunan	29°10'N, 113°50'E	1,200	8 Jan, 1990	Liu et al. 1994 ¹
Qingdao coast	Shandong	36°10'N, 120°10'E	1,000	10 Jan, 1991	Liu 1994
Xingkai (Hanka) Lake ²	Heilongjian ³	45°30'N, 132°30'E	7,500	spring 1988	Li et al. 1994
Hannan Lakes ⁴	Hunan		400	winters regularly	Lu 1990, Hu & Guan 1994
Shenjing Lake	Anhui	30°20'N, 117°00'E	1,150	winter 1992–93	Lei 1999
Huang He (Yellow River)			1,000		J.J. Lu (pers. comm)

¹ LWfG were not surveyed before 1990's though the species was common (Lei Gang, pers. comm.)

² usually 3,000–5,000 LWfG stage in spring, late March – early May

³ and adjacent parts of Russia

⁴ in the South Dongting Lake area

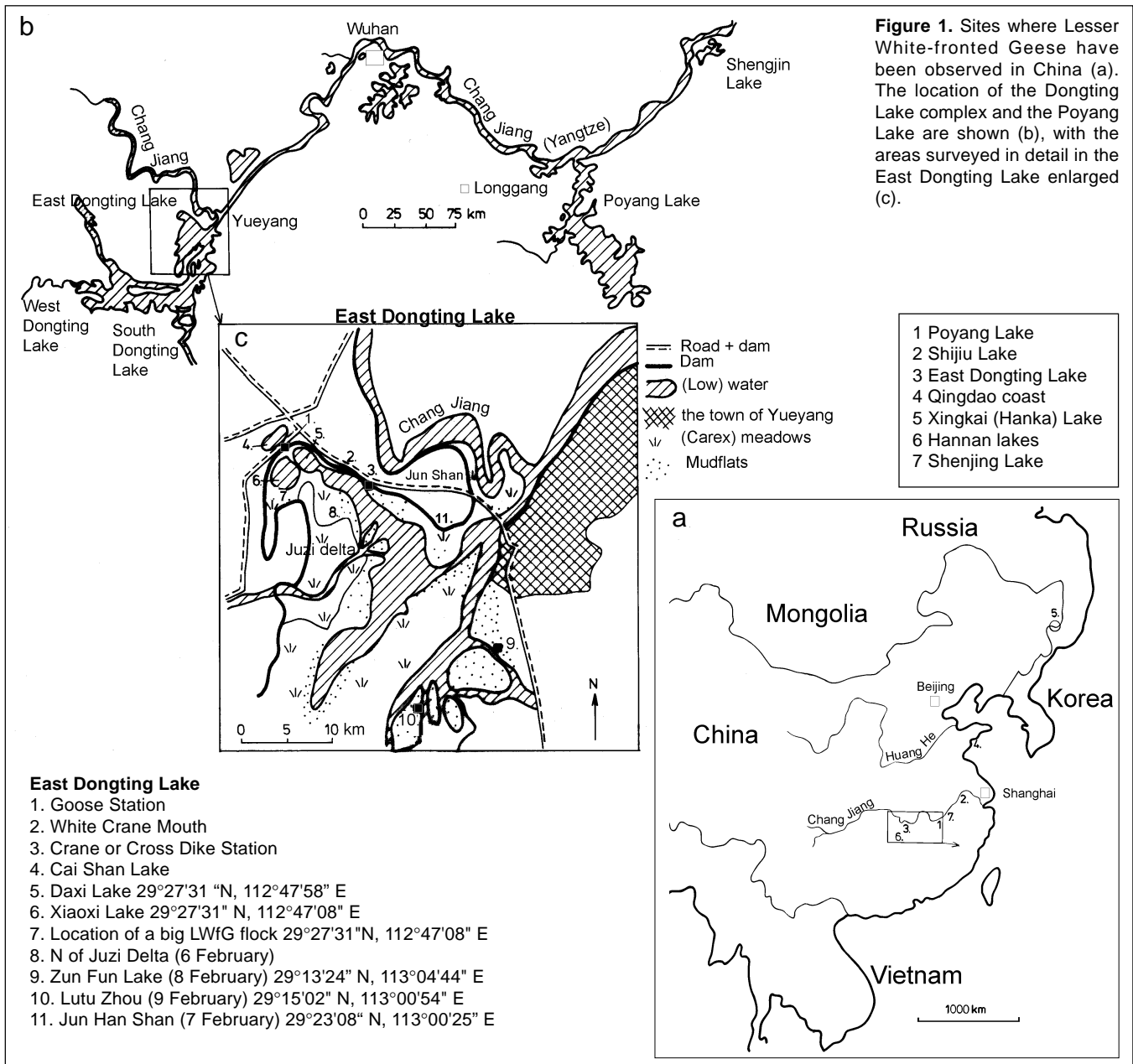

Natural habitats like sedge (*Carex*) meadows, mudflats and sandbanks cover c. 610 km² and the rest c. 90 km² is mainly covered by pasture land and agricultural fields.

The first zone upwards from the waterline consisted of bare mudflats and sand banks, and the next zone was made up by slightly higher mudflats mostly covered by plants as small clones of sedges, grasses and *Dicotyledons*, especially *Rorippa* sp. Also *Polygonum lapathifolium* was identified in this zone. North of the Juzi Delta also creeping *Ranunculus repens*-like buttercup species and small *Polygonum* species resembling *R. hydropiper* were growing below the sedge zone (cf. Anonymous 1997). Further up, sedge (*Carex* spp.) meadows are found, the physiognomy of which greatly depends on the intensity of water buffalo grazing. To the north of the Juzi Delta, the lower-lying edge of the sedge zone was fringed by a narrow grass zone with tussocks of *Juncus* sp. The sedge zone is followed by the reed (*Phragmites* etc.) zone.

Sometimes interference between water buffaloes and geese may occur as approaching buffalo flocks may disturb the geese and chase them away. However, at least during our survey, the geese and especially LWfG seemed to prefer meadows grazed by buffaloes.

Two field stations are located in The East Dongting Lake National Nature Reserve: the Goose Station on the dam of the NW corner of East Dongting Lake and the Crane (or Cross Dike) Station on the

dam following the northern shore of the lake c. 10 km E of the Goose Station (see Figure 1c). The Goose Station has an optimal location between Cai Shan, Daxi and Xiaoxi Lakes (Figure 1c). In winter, Daxi and Xiaoxi appear as separate lakes, but they unify when the water level rise. The soil consist of clay, mud and other fine fractions and is very dry and hard in winter. The shores of Daxi Lake near the Goose Station were intensively grazed by geese. The sedge meadows SE of the Goose station, N of the Juzi Delta (Figure 1c) are nearly 5 km wide, and at least in the winter 1998/99 they were at most only slightly grazed by water buffaloes, and seemed to be too highly growing to be suitable as feeding habitat for geese.

The open shores of Jun Han Shan (Figure 1c) are vast, and are told to be a major grazing place of geese when the water level is high. However, during our visit, no geese were observed due to low water levels. In 1996, c. 5,000 geese (mainly White-fronted Geese (*Anser albifrons*), but no LWfG) were observed here. Two poachers were caught here at that time. In the Zun Fun Lake area (Figure 1c) the sedge meadows were heavily grazed, and with only small amounts of litter or dry old vegetative parts.

Since 1983, the East Dongting Lake has been a Ramsar site. Until 1994 it was protected according to regional legislation, but then received status as a national protected area. The nature reserve is famous for e.g. wintering Oriental White Storks (*Ciconia boyciana*)



Photo. The meadows at Xiaoxi Lake is among the most frequently used grazing areas for Lesser White-fronted Geese at the East Dongting Lake National Nature Reserve. © Petteri Tolvanen, February 1999

Table 2. Itinerary of the survey.

Date	Itinerary
31 January	Meeting with prof. Jian Jian Lu and He Wenshem at the East China Normal University in Shanghai
1 February	Negotiations with representatives of the regional nature conservation authorities of Hunan Province in Changsha
2 February	Negotiations with director of the East Dongting Lake National Nature Reserve in Yueyang; short visit to the Cross Dike station (point 3 on Figure 1) area in the East Dongting Lake National Nature Reserve
3 February	East Dongting Lake: surveys in NE parts of the East Dongting Lake National Nature Reserve (White Crane mouth, point 2 on Figure 1, Goose station, point 1)
4 February	East Dongting Lake: surveys at Daxi (point 5) and Xiaoxi (point 6) lakes and at the Goose station
5 February	East Dongting Lake: surveys at Daxi and Xiaoxi lakes, at the Cross Dike and Goose stations and at White Crane Mouth; meeting with the director of the East Dongting Lake National Nature Reserve in Yueyang
6 February	East Dongting Lake: survey of the area N of Juzi Delta (8 km S of the Goose station, point 8)
7 February	East Dongting Lake: surveys at Xiaoxi Lake, at the Goose Station and at White Crane Mouth, Jun han Shan (point 11) meeting with representatives of Hinganskiy Nature Reserve, Amur Oblast, Russia
8 February	East Dongting Lake: survey at Zun Fun Lake (point 9) E of East Dongting Lake, SW of the town of Yueyang
9 February	East Dongting Lake: survey by boat in East Dongting Lake, Lutu Zhou (point 10)
10 February	Travelling from East Dongting Lake to Poyang Lake
11 February	Poyang Lake: surveys SW of the headquarter of the Poyang Lake National Nature Reserve, e.g. at the Dahutsi shore (29°09'N, 115°58'E), discussions with the directors of the Poyang Lake nature reserve
12 February	Poyang Lake: surveys by boat in the vicinity of the headquarters of the Poyang Lake Nature Reserve (e.g. Zhonghuzi Lake, Banghu Lake)
13–14 February	Travelling, Poyang Lake – Changsha – Shanghai; meeting with prof. Jian Jian Lu and He Wenshem at the East China Normal University in Shanghai

enumerating up to 800 individuals. According to the management plan for the area, 233 bird species, 115 fish species and c. 700 plant species have been registered within the reserve (Anonymous 1997).

2.2. Poyang Lake

Poyang Nature Reserve was established in 1983 by the regional government. In 1989 it became a nature reserve of national status. It covers an area of 202 km², which is only a small part of the whole Poyang Lake (covering c. 4,500 km²). When the water level is high, there are two lakes in the reserve, but they are divided into eight parts when the water level decreases. The nature reserve employs 46 persons, working under the leadership of the board of forestry of the province.

A total of 306 bird species, 122 fish species, 45 mammals and 45 amphibians and reptiles have been observed in the nature reserve as well as 227 insect species and 300 plant species. Poyang Lake is the main wintering quarter for Siberian White Cranes (*Grus*

leucogeranus) and Swan Geese (*Anser cygnoides*) in the world.

3. Methods

The estimation of the total number of geese was based on direct counts of grazing and sometimes flying flocks. At East Dongting Lake we tried to visit as many parts of the nature reserve as possible and we succeeded to survey the main parts of the NW, N and E shores, but only small parts of the SE shores. The W and SW shores were left practically unchecked. We divided in smaller groups and visited two or three places simultaneously in order to avoid double counting. We also interviewed buffalo herdsman and other local people about the diurnal rhythm and flight directions of the geese. At Poyang Lake, shortage of time restricted our survey to the easiest accessible sites (close to the road, and along the river from a boat). Goose families typically aggregate in particular parts of a larger flock

Table 3. The highest goose counts in six different parts of East Dongting Lake National Nature Reserve in February 1999. The numbers after the place name refer to Figure 1b. The numbers below show the highest count per place per species, except for the Crane Station, where the birds (e.g. White-fronts) may overlap with those counted in the first area and are not listed here; the term "many" refer to impressions based on interviews. The flock of 5,000 LWfG at the Crane Station (figures marked with *) could totally or partly overlapped with flocks observed at other places, but this could not be confirmed by simultaneous counts. A.ery = Lesser White-fronted Goose (*Anser erythropus*), A.alb = White-fronted Goose (*A. albifrons*), A.ery/alb = one of two former species or both, A.fab = Tundra Bean Goose (*A. fabalis serratirostris*), A.cyg = Swan Goose (*A. cygnoides*), A.ans = Greylag Goose (*A. anser*) and A. sp = *Anser* sp.

Locality	A.ery	A.alb	A.ery/alb	A.fab	A.cyg	A.ans	A. sp	Total
White Crane Mouth –
Goose St. – Xiaoxi (1, 2, 4–6)	7,300	5,360	–	3,200	1,000	157	–	17,017
Crane Station (3)	*5,000	–	–	–	–	–	–	*5,000
Jun Han Shan (11)	–	–	–	–	–	–	"many"	"many"
Zun Fun Lake (9)	–	–	–	100	–	–	100	200
Lutu Zhou (10)	4,500	83	17	642	2	–	2,712	7,956
Juzi Delta	–	–	–	–	–	–	"many"	"many"
Total minimum	11,800	5,443	17	3,942	1,002	157	2,812	25,173
	*16,800							*30,170

(see results). Therefore, the sampling of brood size and age ratios was carried out separately. For a thorough description of the methods, see Tolvanen et al. (1999).

For the study of habitat use (4–5 February), an area consisting of grasslands, mud-flats and open water was scanned by telescope and every individual was registered according to species and habitat type used. The size of the different habitats in the area were not measured, but it was sufficiently available area in every habitat type to reflect the habitat preference of each goose species. We carried out two bouts of samples, the first one consisting of altogether 2,896 individuals, and the second one of 877 individuals.

Behavioural studies on the LWfG were carried out 5 February, and the behaviour was categorised as feeding, watching, preening, sleeping, drinking, alarming, moving (walking) and aggression. We implemented the sampling in two different parts of grassland (1,384 and 1,434 individuals were sampled, see Table 5) and in mud-flats (only 75 LWfG sampled) and open water (only 3 LWfG present). We scanned the flock with the telescope and registered the behaviour of every individual according to the first glimpse we got of it. The mortality rate of adults was roughly calculated according to the presence or absence of both parents in goose families.

4. Results and discussion

4.1. Total number and movements

4.1.1. East Dongting Lake

A summary of the highest counts of geese is shown in Table 3. We have the impression that the flocks seen at the Goose and Crane Station, White Crane Mouth, Cai Shan Lake, Daxi lake, Xiaoxi Lake and even the northern side of Juzi Delta (numbers 1, 3, 2, 4, 5, 6, 8 on Figure 1c) are mostly the same birds, while the geese at Jun Han Shan probably are not.

At Jun Han Shan we heard from local people, that the geese normally arrive to the grazing areas from SE, to which direction they also depart. In the morning of 7 February, the first flock came from E and the second one from S, and both returned back to the direction from where they arrived. This means that the geese of Jun Han Shan probably stay in the huge mud-flat and low-lying meadow area in the central parts of the East Dongting Lake, in low-water conditions W of the river system flowing N towards the Yangtze. They could theoretically overlap with the geese visiting Zun Fun Lake (number 9 on Figure 1c) c. 15 km SE or Lutu Zhou 20 km S, but probably they do not. Near the Crane (Cross Dike) Station the geese usually graze in the morning, and later they probably leave in W direction.

At the Goose station we observed quite regular evening flights of White-fronts and Bean Geese (*A. fabalis*) to NW-NE and back over Cai Shan Lake, but the main part of the LWfG stayed in the Daxi and Xiaoxi lakes the whole day.

The total number of LWfG observed during the East Dongting

Lake survey was 11,800 (minimum estimate) – up to 16,800 individuals (Table 3). The second most numerous species was the White-fronted Goose with c. 5,400 individuals and the Eastern Tundra Bean Goose (*A. fabalis serratirostris*) was the third most numerous with c. 4,000 individuals. We also registered c. 1,000 Swan Geese and some few Greylag Geese (*A. anser*). The maximum figures of Swan Geese are c. 5,500 at East Dongting Lake, but this winter probably less than 2,000 wintered there (Lei Gang pers. comm.).

Altogether we counted 25,000–30,000 geese (Table 3). Probably quite many more were present in Jun Han Shan and the Juzi Delta areas, as well as in parts of the lake that we did not visit. Before 1980, as many as 200,000 geese were counted in eastern parts of East Dongting Lake at Gao Shan Wan (according to the staff of the nature reserve). Even in 1998, 10,000 geese were seen there, but the area is at present quite disturbed, and poaching by poisoning is common.

In April, 1999, Lei Gang repeated the LWfG survey during the pre-migration period, resulting in the highest ever record of 16,500 individuals in one day at Daxi Lake in the East Dongting Lake. This is very close to our maximum estimate. According to this and other recent observations (Iwabuchi et al. 1997, Lei 1999), it is typical that LWfG concentrates to the vicinity of the Goose Station during the pre-migration period in March–April, when the greatest flocks as well as the peak total numbers have been counted. This is probably a consequence of upheaval of the water level in spring when the low-lying central parts of the lake system are flooded, but probably indicates also the most safe conditions near the station. This phenomenon should be considered when planning future inventory schedules.

4.1.2. Poyang Lake

On 11 February at 12:30, when entering the Poyang Lake Nature Reserve, we observed a goose flock of c. 3,000 individuals on the NW side of the road. All properly identified individuals were White-fronts, but we also heard Bean Goose voices. Later on we took samples from the same flock, and all the 300 identified individuals were White-fronts. Approximately 1,000 more geese were observed flying from long distance. At 15:55, the Dahutsi shore (29°08'59"N, 115°58'23"E) SW of the station was visited. There we counted 1,750 geese, most of them being White-fronted Geese, but with at least 30 Bean Geese.

On 12 February (between 09:30–14:05) we searched for geese at Poyang Lake (incl. Zhonghuizi Lake and Banghu Lake) by boat. No LWfG were found, but c. 1,300 White-fronts and 300 Bean Geese were observed.

According to the staff (director Zhao and assistant director Yi, pers. comm.), the Poyang Nature Reserve is the most important wintering quarter for Swan Geese enumerating up to 31,000 birds (the world population is estimated at 50,000). White-fronted Goose is the second most numerous species with up to 27,000 birds. Bean Goose, Greylag Goose and LWfG are scarce, with less than 200 birds each. Also Bar-headed Goose (*A. indicus*) (max. 32 individuals), Snow Goose (*A. caerulescens*) and Red-breasted Goose (*Branta*

ruficollis) have been observed in the area.

According to Mr. Zhao and Mr. Yi, too little attention has been given to the occurrence of LWfG in the Poyang Lake area, but it seems obvious, that the information about 6,000 LWfG presented at the Anatidae 2000 conference in 1994 (Anonymous 1995) was incorrect. Their impression was that LWfG has not been (at least for a long time) a common species at the Poyang Lake. The numbers of White-fronted Geese has decreased in the area, probably due to poaching (by poison). The maximum count mentioned above is from the 1980's.

4.2. Brood size and age ratio

The brood size data were sampled mainly 4–5 February on the SW side of Xiaoxi Lake (n=139 broods), some broods on 3 and 4 February in the vicinity of the Goose Station (Daxi Lake, n=8) and on the mud-flat islands of Lutu Zhou 9 February (n=7). The average brood size of the LWfG was 2.9 goslings per family (n=154 broods, SD=1,33). At Lutu Zhou the average brood size was 2.7 immatures. (n=7).

For the White-fronted Goose, the average brood size in a sample of 43 families was 3.2 (SD= 1.28). In both species (White-fronted Goose and LWfG), the brood size was considerably higher as compared with other goose species (Table 4).

The proportion of immature LWfG (2nd calendar-year birds) was 36% (n=430), which is quite high taking into account the time of the survey. During the previous winter (1997-98), the proportion of juveniles was c. 20 % (Lei Gang, pers. comm.).

In the most important autumn staging area on the western flyway for LWfG, the Kustanay region in north-western Kazakstan, the proportion of immatures was 33 % in October 1996, 43 % in October 1998 (Tolvanen et al. 1999), and 44 % in October 1999 (Tolvanen et al. 2000, pp. 43–50 in this report).

For White-fronted Geese wintering in Europe, the average proportion of immatures was as high as 34% in 1950's but decreased to 27% in the first half of the 1990's (Mooij et al. 1999). In the Taiga Bean Goose (*A. fabalis fabalis*), percentages between 16.7 and 32.5 have been reported in different winters and sites (Nilsson et al. 1999). For the Tundra Bean Goose (*A. fabalis rossicus*) wintering in western Europe the proportion of immatures varied greatly in the 1980's, between the limits of 9.1 and 41%, with an average of 21.7 % (van den Bergh 1999).

In Pink-footed Geese (*A. brachyrhynchus*) the average immature proportion in the years 1975-79 was as low as 11.7 (Mitchell et al. 1999), and for Russian Barnacle Geese (*Branta leucopsis*) fluctuations in immature proportions have been high; between 1 and 50% in the period 1960–1990, while in the 1990's the average proportion of immatures has been less than 20% (Ganter et al. 1999). In Brent Goose (*B. bernicla bernicla*) populations breeding in Russia, the proportion of immatures vary between 0 and >50%, while the average in the period 1980–1990 was <20%. Thus, the reproductive rate of the Far East LWfG population seems to be quite high, but the data is still limited to very few years, and should be treated cautiously.

In the great LWfG flock present near the Goose Station during our survey at East Dongting Lake, the families with young were concentrated to the marginal parts of the flock. Also White-fronted Geese showed the same pattern. All samples that was suspected to be biased due to such flock composition were removed from the



Photo. Lei Gang (left) and Shigeki Iwabuchi collecting brood size data on Lesser White-fronted Geese at Xiaoxi Lake, East Dongting Lake National Nature Reserve. © Petteri Tolvanen, February 1999

final results.

4.3. Habitat use and behaviour

The sampled mixed goose flock studied on 4 February consisted of altogether 10,700 geese, with White-fronted Goose being the most numerous (see Chapter 5.1). The flock sampled on 5 February enumerated 9,490, with the majority being LWfG. The total number of geese included in the habitat samples was 1,965 LWfG, 853 White-fronts, 817 Bean Geese, 76 Swan Geese and 34 Greylags.

LWfG mostly used grassland (88%), and White-fronted Geese seemed to prefer the same habitat as LWfG: grassland (78–92%), Swan Geese were usually seen on open water (52–65%), and Bean Geese and Greylag Geese mostly used mud flats (58–75%).

The content of the muscle stomach of a poisoned 2nd calendar-year male LWfG was studied, and all 50 identified food items were *Rorippa* sp. (resembling the European species *R. palustris*). Of this genus, the Management Plan (Anonymous 1997) lists four species; *R. montana*, *R. cantoniensis*, *R. indica* and *R. globosa*. Also the stomach content of one poisoned Bean Goose *Anser fabalis serrirostris* was studied, and it consisted completely (50 items) of sedge (*Carex*) leaves. The LWfG individual had been foraging on a lower zone and the Bean Goose on a higher zone, which is somewhat contradictory to our results on habitat use patterns for these species.

Most of the time, LWfG in the great flock were grazing (77 %; see Table 4), while in 8% of the time they were moving (some of the walking geese were grazing at the same time, but are included in this category) and 6% of the time they were watching. More irregular behavioural features were sleeping (4 %), drinking (2%) and aggressions (0,07 %). The low proportion of time spent for watching, reflects the advantage of forming a great flock. For example in the small groups staging at the Finnish stop-over sites, the percentage of vigilant behaviour was measured to 18.8-22.4 % (Markkola et al. 1998).

4.4. Mortality

The average number of adults in LWfG families was 1.98 (n=154) . The corresponding number for the White-fronted Goose was 1.93 (n=43). We did not see single immature individuals, nor broods without parents.

Assuming that the mortality risk for every adult LWfG is independent of the mortality risk of its mate, would yield a mortality rate of only 0.97 % (= $100 \times 3 / 2 \times 154$; the probability for both parents in the same family being killed would be very low: 0,009 %

Table 4. Brood size in some goose species and populations sampled during the winter.

Species	Population	Year	Brood size (mean)	Source
Pink-footed Goose	Iceland/Greenland	1970–94	1.9–2.4	Mitchell et al. 1999
Greylag Goose	Iceland	1970–94	1.8–2.3	Mitchell & Sigfusson 1999
Barnacle Goose	Greenland	1984,1987	1.9–2.2	Cabot et al. 1988
Light-bellied Brent Goose	Canada	1977–93	1.7–3.2	Merne et al. 1999

Table 5. Time budgets of the behaviour of LWfG at Xiaoxi Lake (29°27'31"N, 112°47'08"E) in the East Dongting Lake in China in February 1999, 5 February 1999, 08:45–10:03.

Habitat	Grazing	Watching	Preening	Sleeping	Drinking	Moving	Aggress.	Total ind.
Grassland	78 %	4 %	3 %	0 %	4 %	11 %	0 %	1,384
Grassland 2	81%	9 %	2 %	2 %	1 %	5 %	0 %	1,434
Mudflats	0 %	0 %	0 %	100 %	0 %	0 %	0 %	75
Open water	0 %	0 %	0 %	100 %	0 %	0 %	0 %	3
All habitats	77 %	6 %	2 %	4 %	2 %	8 %	0 %	2,896

with probably no cases among 154 families) for adults between the nesting period and February, even though this time-span includes the critical autumn migration and roughly half of the winter.

In the morning of 3 February, we witnessed poachers picking up 10–20 poisoned LWfG on the mud-flats at the White Crane Mouth. In addition, they left three dead 2nd calendar-year LWfG on the ground.

According to observations by Lei Gang, LWfG are much more shy than other geese. On the other hand LWfG stay for a longer period in the area compared with other goose species, making them more vulnerable to poaching. It is typical that LWfG are the last geese to leave the lake (sometimes together with small numbers of White-fronts and Bean Geese) as late as 15 April. If LWfG stay at Dongting Lake from early November to early April, the poachers have five months, i.e. 150 days for goose poaching. Assuming a mean of 23 LWfG daily killed – as we observed in this one case – an estimated 3,450 individuals is killed during the 150 days wintering period.

The estimate of Lei Gang was >1,000 LWfG poisoned every winter in the East Dongting Lake reserve, which mean > 8.5 % of our minimum estimate of the Dongting Lake LWfG winter population and > 6.0 % of the maximum estimate. The estimate of 3,450 LWfG killed yield mortality rates of 29.3% and 20.5 % respectively. The annual mortality rate of non-protected geese in the Western Palearctic is commonly 25–30 % (Ebbinge 1991). Protection may decrease the figure to c. 15 %, of which still 50% is caused by hunting (Ebbinge 1991). An annual mortality rate of >30 % is too high for any goose species in order to keep a stable population.

More precise studies on the effect of poaching and measures to limit it are inevitable at the East Dongting Lake. It is probable that effective conservation measures at the East Dongting Lake would lead to a quick recovery of the LWfG Far East population.

5. Conservation status and needed improvements

The East Dongting Lake National Nature reserve is one of the core areas for conservation of the LWfG in the whole world. The huge meadows around the East Dongting Lake offer extremely favourable conditions for the wintering LWfG. However, poaching by poisoning is a serious threat, and it should be effectively limited in the future. Another serious threat for wintering geese in the area in the future could be the effects on the water level caused by the Three Gorges Dam under construction in the Yangtze River. The expected effect of the dam is an increase in water level during winter, which may reduce available grazing habitat for geese.

According to the staff of the East Dongting Lake National Nature Reserve, the status of the nature reserve is sufficient and the financing situation adequate. However, the protection is not satisfactory even in the strictly protected core zone including the Daxi and Xiaoxi lakes, and in the outer zone it is e.g. allowed for one hunter to catch ducks with nets. Further away from the strictly protected part, the situation is more serious: e.g. ca 10 km south, –at the Juzi Delta, waterfowl hunting by poisoning is common, and to a lesser extent also hunting by shotguns.

During the winter 1998–1999, two poachers had distributed 6 kg poison (alphachlorolose) and killed 200 geese in this area (Lei Gang, pers. comm). Also in more southern areas poisoning has taken place (e.g. two poachers were captured there in January 1996), but at present this area is probably too over-grown by reeds and the geese may more or less have abandoned the area.

According to observations by Lei Gang, poisoning is most serious after a snow fall; poison particles are probably easily distinguishable for geese that are searching gravel for their muscular stomach.

According to the staff of the Poyang Lake Nature Reserve, the poachers at Poyang Lake utilise both nets and poison, but usually not shotguns to hunt geese, swans and cranes. Netting has decreased due to more efficient inspection by the nature reserve staff. In early 1998, three poachers who had trapped and sold 68 swans were caught and they were prisoned for 2–3 years and had to pay penalties according to a new, more strict legislation directed in 1997. Just before our visit a group of eight poachers, who had killed e.g. Oriental White Storks were caught.

The staff of the Poyang Lake Nature Reserve could not estimate the total hunting bag of poachers in the area. The poaching problem became more serious after the disastrous flood in the summer 1998, that destroyed a lot of crops. Later on, the problem may decrease, because 460,000 inhabitants of the adjacent area will be moved away from the flood-threatened areas. We saw large areas, where former rice fields were flooded, and these areas will be left intact to form new “natural” wetlands and meadows.

6. Summary

East Dongting Lake National Nature Reserve in China has proved to be the most important key area for conservation of the LWfG in the whole world. A team formed by researchers from China, Japan, Finland and Norway surveyed the East Dongting and Poyang lakes, China in the period 2–12 February, 1999. The total number of LWfG observed during the survey was 11,800–16,800 individuals, all at East Dongting Lake. The average brood size was 2.9 immatures (n=154 broods) and the proportion of immatures in the whole population was c. 36% (n= 4310 individuals), indicating a successful breeding season in 1998. LWfG preferred grasslands (88%) and their main behaviour was registered as grazing (77%), walking (8%) and vigilance (6%). In April 1999, Lei Gang repeated the survey during the pre-migration period, when the LWfG flocks gather in the vicinity of Daxi Lake, and counted 16,500 individuals. This is the maximum confirmed count of LWfG at any single site in the world for more than a decade. The need for establishing annual monitoring of LWfG in the East Dongting Lake is obvious, and revealing the occurrence of LWfG at Poyang Lake should also be given high priority. Urgent actions are needed in order to limit poaching of LWfG and to confirm the status of the species as strictly protected in China.

7. Acknowledgements

We are grateful to all people who contributed on our journey and work: the staff of the Dongting Lake and the Poyang Lake nature reserves and

the Forest and Park Service in Changsha, Mr. Chen Jin-Wen and other friendly people in the town of Long Gang, our bus driver Yang Jian Xiang and many others. In addition to the authors of this paper, Minna Ruokonen (University of Oulu, Finland) participated full-time in the surveys, and Jiang Yong (East Dongting Lake National Nature Reserve, China) participated in the surveys at the East Dongting Lake. We like to acknowledge their effort and company.

References

- Anonymous 1995:** Status of the Lesser White-fronted Goose in China. – IWRB Goose Research Group Bulletin. No 6, August 1995:25–26.
- Anonymous 1997:** Management plan of the East Dongting Lake National Nature Reserve. – 112 pp.
- Below, A. & Virolainen, E. 1996:** A trip to East Dongting Lake Nature Reserve in January 1996. – Internal report. Finnish Forest and Park Service. 10 pp.
- van den Bergh, L. 1999:** Tundra Bean Goose *Anser fabalis rossicus*. In: Madsen, J., Cracknell, G. & Fox, T. 1999: Goose Populations of Western palearctic. A review of status and distribution. – Wetlands International Publication No. 48, Wetlands International, Wageningen, The Netherlands. National Environmental Research Institute, Rønde, Denmark. 48:38–66.
- Cabot, D., Goodwillie, R. & Viney, M. 1988:** Irish expedition to north-east Greenland 1987. Barnacle Books, Dublin.
- Ebbinge, B. S. 1991:** The impact of hunting on mortality rates and spatial distribution of geese, wintering in western palearctic. – *Ardea* 79:197–209.
- Ganter, B., Larsson, K., Syroechkovsky Jr., E. E., Litvin, K., Leito, A. & Madsen, J. 1999:** Barnacle Goose *Branta leucopsis*: Russia/Baltic. In: Madsen, J., Cracknell, G. & Fox, T. 1999 (eds.): Goose Populations of Western palearctic. A review of status and distribution. – Wetlands International Publication No. 48. Pp. 270–297.
- Hu, H. & Guan, H. 1994:** Species diversity of waterfowl on the Honghu lake with an assessment of the environmental impacts. In: Lu W. & the Waterbird Specialist Group of the Chinese Ornithological Association (eds.): Waterbird Research in China: 129–134.
- Iwabuchi, S., Ikeuchi, T., Lei, G., Yong, J. & Sun Ping Yue 1997:** Record count of Lesser White-fronted Geese at Dongting lake, China. – Threatened Waterfowl Specialist Group. No. 11, July 1998:7–8.
- Iwabuchi, S., Ikeuchi, T., Matsuda, M. & Matsuda T. 1998:** The short report on survey of Lesser White-fronted Goose (*Anser erythropus*) and the first term of Goose Training Program at Dongting Lakes in China 1998. – Bull. Sendai Science Museum, No 7:98–101.
- Lei, G. 1999:** Action Plan for the Lesser White-fronted Goose (*Anser erythropus*) in China. –Project proposal. 6 pp.
- Li, W., Zhao, H., Li, J. & Feng, S. 1994:** Waterbirds study in Xingkei Nature Reserve. In: Lu W. & the Waterbird Specialist Group of the Chinese Ornithological Association (eds.): Waterbird Research in China: 135–140.
- Liu, D. 1994:** A survey of waterbirds on the Qingdao coast. In: Lu W. & the Waterbird Specialist Group of the Chinese Ornithological Association (eds.): Waterbird Research in China: 174–176.
- Liu, Q., Huang, Z. & Zhang, Z. 1994:** A preliminary study on wetland birds in lake Dongting. In: Lu W. & the Waterbird Specialist Group of the Chinese Ornithological Association (eds.): Waterbird Research in China: 152–156.
- Lu, J. J. 1990:** Current status and distribution of geese in China. – Presentation given to the International Symposium on Wild Goose Populations in Northern Asia. Magadan, USSR.
- Lu, W. & the Waterbird Specialist Group of the Chinese Ornithological Association (eds.) 1994:** Waterbird Research in China. – East China Normal University Press. 234 pp.
- Markkola, J., Ohtonen, A. & Karvonen, R. 1998:** Spring staging areas of the Lesser White-fronted Goose *Anser erythropus* on Bothnian Bay coast: features of spring migration in 1997. In: Tolvanen, P., Ruokolainen, K., Markkola, J. & Karvonen, R. (eds.): Finnish Lesser White-fronted Goose Conservation Project. Annual report 1997. – WWF Finland Report no 9:36–37.
- Merne, O. J., Boertmann, D., Boyd, H., Mitchell, C., Briain, M. O., Reed, A. & Sigfusson, A. 1999:** Light-bellied Brent Goose *Branta bernicla hrota*: Canada. In: Madsen, J., Cracknell, G. & Fox, T. 1999 (eds.): Goose Populations of Western palearctic. A review of status and distribution. – Wetlands International Publication No. 48, Wetlands International, Wageningen, The Netherlands. National Environmental Research Institute, Rønde, Denmark. Pp. 298–311.
- Mitchell, C., Fox, A. D., Boyd, H., Sigfusson, A. & Boertmann, D. 1999:** Pink-footed Goose *Anser brachyrhynchus*. In: Madsen, J., Cracknell, G. & Fox, T. (eds.): Goose Populations of Western Palearctic. A review of status and distribution. – Wetlands International Publication No. 48, Wetlands International, Wageningen, The Netherlands. National Environmental Research Institute, Rønde, Denmark. Pp. 68–81.
- Mitchell, C. & Sigfusson, A. 1999:** Greylag Goose *Anser anser*: Iceland. In: Madsen, J., Cracknell, G. & Fox, T. 1999 (eds.): Goose Populations of Western palearctic. A review of status and distribution. – Wetlands International Publication No. 48, Wetlands International, Wageningen, The Netherlands. National Environmental Research Institute, Rønde, Denmark. Pp. 162–171.
- Mooij, J. H., Faragó, S. & Kirby, J. S. 1999:** White-fronted Goose *Anser albifrons albifrons*. In: Madsen, J., Cracknell, G. & Fox, T. (eds.): Goose Populations of Western Palearctic. A review of status and distribution. – Wetlands International Publication No. 48, Wetlands International, Wageningen, The Netherlands. National Environmental Research Institute, Rønde, Denmark. Pp. 94–128.
- Tolvanen, P., Litvin, K. & Lampila, P. 1999:** Monitoring the autumn staging of Lesser White-fronted Geese in north-west Kazakhstan, October 1998. In: Tolvanen, P., Øien, I.J. & Ruokolainen, K. (eds.): Fennoscandian Lesser White-fronted Goose Conservation Project. Annual report 1998. – WWF Finland Report 10 & Norwegian Ornithological Society, NOF Rapportserie report no. 1-1999:42–46.
- Tolvanen, P., Pynnönen, P., Markkola, J., Aarvak, T. & Øien, I.J. 1999:** Monitoring instructions for Lesser White-fronted goose surveys. In: Tolvanen, P., Øien, I.J. & Ruokolainen, K. (eds.): Fennoscandian Lesser White-fronted Goose Conservation Project. Annual report 1998. – WWF Finland Report 10 & Norwegian Ornithological Society, NOF Rapportserie report no. 1-1999:68–71.
- Tolvanen, P., Eskelin, T., Aarvak, T., Eichhorn, G., Øien, I.J. & Gurtovaya, E. 2000:** Monitoring the autumn staging of Lesser White-fronted Geese in Kazakhstan, October 1999. In: Tolvanen, P., Øien, I.J. & Ruokolainen, K. (eds.): Fennoscandian Lesser White-fronted Goose Conservation Project. Annual report 1999. – WWF Finland Report 12 & Norwegian Ornithological Society, NOF Rapportserie report no. 1-2000:43–50.

Status of Lesser White-fronted Goose in China

Lei Gang

East Dongting Lake National Nature Reserve, Yueyang City, Hunan Province, 414000, P.R. of CHINA

1. Introduction

The Lesser White-fronted Goose (*Anser erythropus*, later LWfG) is a globally threatened species. In Japan and Korea, where it used to be a common winter visitor, LWfG is at present almost extinct. Results from satellite tracking and ringing projects strongly indicate that the most important reason for the decline of the LWfG population is hunting (e.g. Lorentsen et al. 1999, Øien et al. 1999, Tolvanen et al. 1999).

Current studies show that the world population of LWfG is not more than 25,000–30,000 individuals (Tolvanen et al. 1999). Roughly half of these belong to the eastern subpopulation, which breeds in eastern Siberia (east of the Taimyr Peninsula) and winters mainly in China. The East Dongting Lake National Nature Reserve is the most important wintering site known so far, the highest counts being 9,000 ind. in the winter 1989/90 (Liu 1994); 13,700 ind. in spring 1997 (Iwabuchi et al. 1997) and 16,500 ind. in late autumn 1999 (own unpublished data).

Information about the eastern subpopulation of LWfG is very limited. The LWfG population size and its habitat preferences remains poorly understood, especially at its wintering sites in China. In China, LWfG is not protected under the National Special Protection Decree. In the Decree, protected species are divided in first (stricter protection) and second degree categories. Surprisingly, White-fronted Goose (*Anser albifrons* et. spp) is listed as a protected species (second degree), but LWfG is not on the list. There are two alternative explanations for this. First, the expression "*Anser albifrons* et. spp" on the list could mean all goose species with a white front patch. In that case, also LWfG would be protected. Usually, Chinese authorities seem to follow this explanation, but it also means that LWfG has been treated as a subspecies of White-fronted Goose. Alternatively, LWfG is treated as a separate species, and since it is not included on the list, it is unprotected. However, LWfG has usually been treated as a protected species (second degree) in practice.

2. Study activities

2.1. Monitoring

The available data on LWfG from China is very limited. There is no specific monitoring programme for LWfG, as usually only the first degree protected species are monitored annually. However, some persons working for the nature reserves or other research institutions may possess some old unpublished data.

Information from Asian Waterbird Census (AWC) include the following quite recent counts: 7,500 individuals at Xinkai Lake (a staging site) in spring 1988 (Li et al. 1994); 1,150 ind. at Shenjing Lake in winter 1992/93 (AWC); 9,790 ind. at Poyang Lake in winter 1988/1989 (AWC) and 13,700 ind. at East Dongting Lake in winter 1997/1998 (Iwabuchi et al. 1997). According to old monitoring data at Daxi Lake in the East Dongting Lake National Nature Reserve, 1,350 ind. were counted in 1993; 1,500 ind. in 1994;

2,300 ind. in 1995 and 1,800 ind. in 1996. The maximum counts of all goose species in the East Dongting Lake National Nature Reserve are shown in Table 1.

2.2. Research

Most of the research work on LWfG in China has been conducted after 1996, when we for the first time became aware that LWfG is a globally threatened species. Our main aim is to improve the protection of LWfG at the known wintering areas (especially at the East Dongting Lake). In order to achieve this, it is important to establish annual monitoring; to study the habitat use of LWfG, and to reveal what are the most important factors causing the population decline. Unfortunately, our work is suffering from lack of supporting funds.



Photo. The author holding a 2cy Lesser White-fronted Goose killed by illegal poisoning in the core area of the East Dongting Lake National Nature Reserve in February 1999. © Petteri Tolvanen

Table 1. Species composition in the goose flocks in the East Dongting Lake National Nature Reserve in 1997 and 1998.

Species	Highest count in 1997	Highest count in 1998	% 1997	% 1998
<i>Anser albifrons</i>	83,000	60,000	77.2	76.1
<i>Anser erythropus</i>	13,700	9,860	12.7	12.5
<i>Anser fabalis</i>	6,000	5,800	5.6	7.4
<i>Anser cygnoides</i>	4,500	3,000	4.2	3.8
<i>Anser anser</i>	345	180	0.3	0.2

In 1997 the first LWfG arrived on 29 October, and in 1998 they arrived on 11 November. The spring migration northwards starts in late March and ends in mid April, with the peak departure normally between 26 March and 5 April. The juvenile ratio of LWfG is normally in the range 25–30 %.

The most important wintering sites of LWfG in the East Dongting Lake Nature Reserve are the Daxi and Xiaoxi lakes in the north-western part of the reserve, but also the Chun Feng Lake, the White Crane Mouth, He Dang and Piaow Wei are commonly used by LWfG, especially when the disturbance (fishing) at the Daxi and Xiaoxi lakes is high. In early winter, LWfG are usually shy and mixed with White-fronted Geese, so it can be very difficult to count the total population size at that time of year. In spring, especially after the Chinese Spring Festival (normally in February), the LWfG are usually concentrated at the Daxi and Xiaoxi lakes, because the disturbance is relatively low in that period.

In 1997, the staff of East Dongting Lake ringed the first LWfG in China with a colour neck collar. The Bird Ringing Centre of China has no ring recoveries of LWfG.

3. Threats and problems of LWfG conservation in the East Dongting Lake area

3.1. Illegal hunting

The hunting pressure on geese has never been as high as today. Poisoning is the most common way of hunting. In the East Dongting Lake National Nature Reserve, more than 2000 kg of Funandan (a typical poisoning chemical used by poachers) is estimated to be spread in the lake annually. The poachers usually put the poison on the mud flats and the shoreline, that is frequently used by LWfG, while White-fronted Geese usually occupy the higher-laying grass land or open water.

3.2. Habitat loss and degradation

Although we do not have firm evidence that habitat loss and degradation are significant reasons for the drastic decline of LWfG population, suitable feeding habitats for LWfG have decreased by 50% during the last 50 years. According to local hunters, the present density of geese and ducks is far lower than 50 years ago.

3.3. Human disturbance

Human disturbance, especially due to fishing, is also a serious threat for the wintering geese, because more than 20,000 fishermen live in the East Dongting Lake area, with some 180,000 more in the surrounding areas. In order to obtain more income from the lake, many fishermen dry out parts of the lake in order to increase the catch, thus drying out the lake. They also have extended their working hours thus prolonging the disturbance period.

4. Discussion

Efficient conservation work for LWfG can hardly be implemented without international co-operation and support, since China is a developing country. The threats which LWfG are facing are more serious than ever before, and thus the need for an international co-operation in the LWfG conservation work in China is urgent. The most urgent actions in the LWfG conservation would be to establish an efficient guarding system against poaching in the core area of the



Photo. Lesser White-fronted Geese grazing near the Crane Station in East Dongting Lake, February 1997. © Lei Gang

East Dongting Lake National Nature Reserve. It is further important to train Chinese field workers; to estimate the total wintering population of LWfG in China; to reveal the (winter) distribution area and site preferences in the most important areas and to raise public awareness on the status of LWfG.

References

- Iwabuchi, S., Ikeuchi, T., Lei, G., Yung, J. & Sun Ping Yue 1997:** The short report on survey of Lesser White-fronted Geese at Dongting Lakes in China. – Bulletin of the Sendai Science Museum No 7:103–105.
- Li, W., Zhao, H., Li, J. & Feng, S. 1994:** Waterbirds study in Xingkei Nature Reserve. In: Lu W. & the Waterbird Specialist Group of the Chinese Ornithological Association (eds.): Waterbird Research in China: 135–140.
- Liu, Qi-de. 1994:** Preliminary study on the birds of wetland in Lake Dongting. – Water bird research in China. Pp. 152–156. (in Chinese with English summary)
- Lorentsen, S.-H., Øien, I. J., Aarvak, T., Markkola, J., von Essen, L., Faragó, S., Morozov, V., Syroechkovski Jr., E. E. & Tolvanen, P. 1999:** Lesser White-fronted Goose *Anser erythropus*. In: Madsen, J., Cracknell, J. & Fox, T. (eds): Goose Populations of the Western Palearctic. A review of status and distribution. – Wetlands International Publ. No. 48. Wageningen, The Netherlands. National Environmental Research Institute, Rønde, Denmark. Pp. 144–161.
- Øien, I. J., Tolvanen, P., Aarvak, T., Litvin, K. E. & Markkola, J. 1999:** Surveys and catching of Lesser White-fronted Geese in Taimyr Peninsula – preliminary results on autumn migration routes mapped by satellite telemetry. In: Tolvanen, P., Øien I.J. & Ruokolainen, K. (eds.): Fennoscandian Lesser White-fronted Goose conservation project. Annual report 1998. – WWF Finland Report 10 & Norwegian Ornithological Society, NOF Rapportserie Report no.1-1999:37–41.
- Tolvanen, P., Markkola, J., Aarvak, T. & Øien, I. J. 1999:** Introduction. In: Tolvanen, P., Øien, I. J. & Ruokolainen, K. (eds.): Fennoscandian Lesser White-fronted Goose conservation project. Annual report 1990. – WWF Finland Report 10 & Norwegian Ornithological Society, NOF Rapportserie Report no. 1-1999:5–8.

Monitoring of Lesser White-fronted Geese in western Estonia in 1999

Petteri Tolvanen¹, Risto Karvonen², Petro Pynnönen³ & Aivar Leito⁴

¹ WWF Finland, Lintulahdenkatu 10, FIN-00500 Helsinki, FINLAND, e-mail: tolvanen@sll.fi

² Järvitie 34, FIN-36110 Ruutana, FINLAND, e-mail: karvonen@vip.fi

³ Kilonkallio 10 F 52, FIN-02610 Espoo, FINLAND

⁴ KKI, Akadeemia 4, 51003 Tartu, ESTONIA, e-mail: leito@envinst.ee

1. Introduction

An important spring staging area for Lesser White-fronted Geese (*Anser erythropus*, later LWfG) was revealed at Matsalu Bay, western Estonia, in 1996, and a minimum of 32 LWfG were seen in the area in April–May 1998 (Tolvanen 1999) without systematic searching. In spring 1999, the first organised monitoring of LWfG in western Estonia covered the period 23 April – 11 May. The work was carried out by volunteers of the Finnish WWF LWfG project, in co-operation with Estonian ornithologists. In autumn 1999, a small-scale survey trip to the same area was made in order to check for possible autumn staging LWfG.

2. Methods and weather conditions

The main aims of the spring monitoring in western Estonia are to:

- reveal the numbers and age ratio of LWfG staging in the area (identifying individually as many as possible)
- localise the most important feeding and roosting areas for LWfG
- assess possible threats for LWfG in the area during the staging period
- collect data for the research on the migration routes of the Fennoscandian wild LWfG population, especially by recording the individual belly patches of adult individuals

The spring monitoring started 23 April, and lasted until 10 May. Altogether 16 persons took part in the work (Table 1), and all the potential feeding and roosting areas around the Matsalu Bay were checked several times, and the core area for LWfG (the fields and coastal meadows of Haeska) were monitored daily (see Table 1, Figure 1). During four days, a survey was carried out also in the Noarootsi Peninsula north of Matsalu. After the 17 days of monitoring in the Matsalu area, a one day survey trip was made in the Pärnu region in south-western Estonia. In addition, observations were received from other Finnish ornithologists birding in the area.

The geese were mainly observed from birdwatching towers and from field roads. When possible, the LWfG were recorded on videotape by a combination of a telescope (Leica Apo-Televid) and digital video camera (Canon MV-10); altogether 25 individuals were recorded.

In the second half of April the weather was very warm (with prevailing S – SE winds and daily maximum temperatures up to +21°C), but turned much colder in the end of April. During the first two weeks of May, there was frost in most nights and daily maximum temperatures varied between +3° and +10°C. On 9 May, it was snowing heavily the whole day, and in the morning of 10 May there was 10 cm snow on the ground in the Matsalu area.

During 17–21 September, a group of Finnish and Estonian ornithologists (Risto Karvonen, Maire Toming, Juha Markkola and Aleksei Lotman) made a short survey trip to western Estonia to search for LWfG. On 17 September, the fields at Taebala, Noarootsi, Ridala and Martna in north-western Estonia were checked; on 18 September, the coastal meadows and fields around Pärnu, Varbla (Saulepi meadow), Töstamaa (Värati meadow) and the Audru fields were visited. During 19–20 September, surveys were carried out in the Lihula area and at Kloostri, and on 21 September, the Martna fields were checked once again.

3. Results of the spring monitoring

A total of 43–51 LWfG were observed during the monitoring period. The lowest number is a minimum, but more probably the real number of observed individuals was closer to 50. The exact number was not possible to determine, because only c. half of the individuals were individually identified and recorded on video.

The first LWfG (groups of 2 + 12 individuals) were seen already the first day, 24 April. The highest direct count at one place was 43 individuals at Haeska on 26 April (with 3 more possibly different

Table 1. Schedule of LWfG monitoring in western Estonia in spring 1999 (see also Figure 1). Abbreviations of the observers: José Luis Copete (JLC), Heikki Holmström (HH), Risto Karvonen (RK), Aura Koivisto (AK), Pekka Komi (PK), Katriina Könönen (KK), Aivar Leito (AL), Mauri Leivo (MLe), Mariko Lindgren (MLi), Juha Markkola (JM), Ivar Ojaste (IO), Jorma Pessa (JP), Petro Pynnönen (PP), Risto Sauso (RS), Petteri Tolvanen (PT), Maire Toming (MT), Vello Vichterpal (VV). Column 2 (Matsalu Bay W) includes the north-western coast of the Matsalu Bay between Puise and Saardo; column 3 (Matsalu Bay E) includes the eastern parts of the Matsalu Bay, including Kasari and Kloostri; column 4 (Matsalu Bay S) includes the southern coast of the Matsalu Bay from Matsalu to Saastna; column 5 (Inland fields) includes the fields N and NE of Haeska, e.g. the fields at Ridala, Tagavere and Martna; column 7 (SW Estonia) includes the Pärnu region.

Date	Haeska	Matsalu Bay W	Matsalu Bay E	Matsalu Bay S	Inland fields	Noarootsi Peninsula	SW Estonia	Observers
24 Apr	x	x			x			PT, MLi
25 Apr	x		x		x			RK, HH, JP, JM, AL, MT, PT, MLi
26 Apr	x	x	x	x	x			RK, HH, AL, JP, JM, MT, PK
27 Apr	x							RK, HH, AL, JP, JM, MT
28 Apr	x		x	x				RK, HH, AL, MT, PK
29 Apr	x		x	x				RK, HH, AL, MT, IO, PK
30 Apr	x				x			RK, HH, MT, MLe
1 May	x				x			RK, HH, AL, MT, MLe, VV
2 May	x				x	x		RK, HH, MT, PP, JLC, KK
3 May	x							PP, JLC, KK
4 May	x					x		PP, JLC
5 May	x	x		x				PP, JLC
6 May	x	x			x			PP, JLC
7 May	x	x			x			PP, JLC
8 May	x				x	x		PP, JLC
9 May	x	x				x		PP, JLC
10 May	x							PP, JLC
11 May							x	PP, JLC

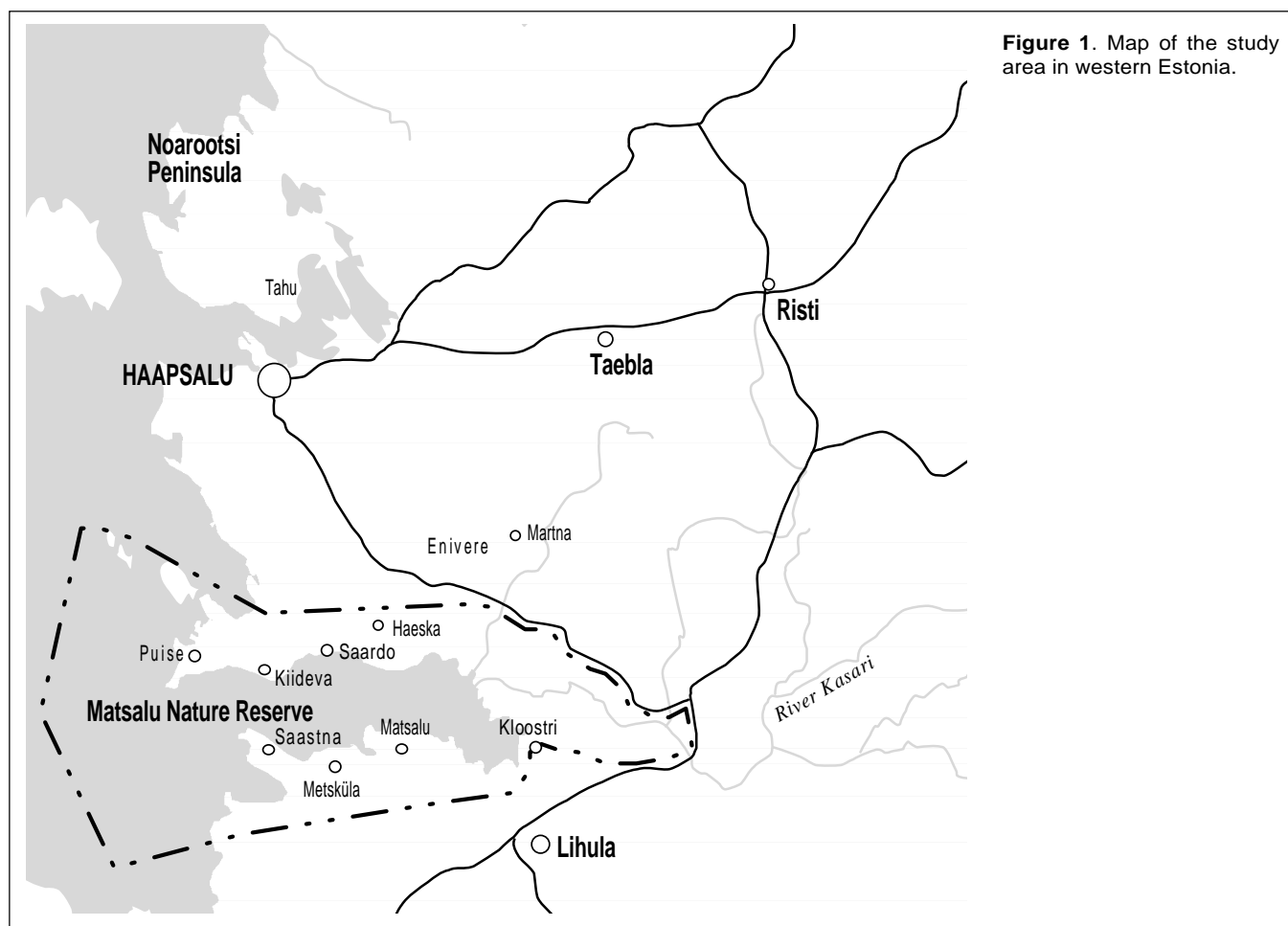

Figure 1. Map of the study area in western Estonia.

individuals seen at Kiideva and at the south coast of Matsalu Bay), which was the peak day during the monitoring period. Most of the observations of LWfG were from the Haeska area, but scattered observations were made in a relatively large area around the Matsalu Bay: in the Martna fields (Enivere, Ehmja, Putkaste), Kiideva (flying birds), Saardo fields, Metsküla coastal meadow, Tagavere (flying birds) and Tahu coastal meadows. A summary of all LWfG observations are shown in Table 2. Most of the individuals were adults (older than 2nd calendar-year), and only three 2nd calendar-year birds were identified. The results of the comparison of the video material from Estonia, the Bothnian Bay coast and the Valdak Marshes (Porsangen Fjord, northern Norway) are reported in a separate article (see Aarvak et al. 2000, pp. 24–27 in this report);

The flock of c. 22 LWfG, which was feeding daily on the eastern side of Haeska birdwatching tower in the period 24 April – 1 May, did not use this area during 2–4 May, but was seen there again 5–6 May. Most probably the flock continued the migration towards north after 6 May, because they were not found after that date despite active searching. When the flock was not feeding in the fields of Haeska, it most probably stayed in other parts of the Matsalu Bay coast at daytime. On one occasion, the flock was seen landing at the Saardo fields (c. 3 km west of Haeska) – this area is not used for grain-growing, but is a pasture for cattle. Excrements of geese were found on these quite small fields.

During daytime, several hundreds of *Anser* geese were roosting in flocks on the water. They could be seen from Haeska by telescope, but species identification of these flocks was impossible. In addition to the LWfG flocks of wild origin, one adult LWfG with Swedish colour-rings was observed in a big flock of Barnacle Geese (*Branta leucopsis*) at Haeska, at the base of Puise Peninsula and at Martna (see Table 2). The last observation (of one LWfG) was made 20 May in Haeska (Estonian Birding Society/ I. Ojaste, J. Pulli, T. Aartolahti).

In the end of April and on the first days of May (when the big flock was present), the daily movements of LWfG seemed to be quite

well defined: They spent early morning hours grazing on the fields (especially on the fields at Haeska), flew in the forenoon to the coastal meadows of Haeska, turned back to the fields in the evening and then they flew to Haeska (Matsalu Bay coast) to roost overnight. When feeding on the fields, LWfG mostly preferred green hay fields and hay-growing pastures. On the coastal meadows, LWfG were mostly feeding in the low-growth (grazed by cattle) green parts of large, open meadow areas. Inside the Matsalu Nature Reserve (established in 1957), there was very little disturbance of the geese during the monitoring period. In some single cases, the geese were scared away (or did not land) because of birdwatchers and/or photographers.

4. Results of the autumn survey

In September 1999, LWfG were seen in one occasion: in the morning 19 September 3 + 1 adult birds were observed together with some White-fronted (*Anser albifrons*), Bean (*A. fabalis*) and Barnacle Geese in a flock of c. 1000 Greylag Geese (*A. anser*) at the Pagasi fields (Kloostri, E parts of the Matsalu Nature Reserve). The origin of these four LWfG could not be identified e.g. by possible rings; they could have been either wild or Swedish re-introduced birds. In the evening of 20 September, voices of LWfG were heard from a mixed flock of Greylags, Bean Geese, White-fronts and 5–7 unidentified white-fronted geese (*A. erythropus/albifrons*).

On 15 October 1999, two more observations of LWfG were reported from Estonia: at cape Pöösaspea (Läänemaa): 1 individual migrating in a flock of White-fronted and Barnacle Geese, and at Risti (Läänemaa), 5 individuals migrating in a flock of White-fronted and Bean Geese (Ivar Ojaste, pers.comm.). The Estonian Rarities Committee has rejected LWfG from the list of species for which observations should be considered by the Rarities Committee, and only records from 1997 or before will be considered (Lilleleht 1999).



Photo. A view of the Haeska coastal meadows, western Estonia, April 1999. © Petteri Tolvanen

Table 2. Summary of LWfG observations during the spring monitoring. For abbreviations of the observers, see Table 1. Other abbreviations: ad = adult, 2cy = 2nd-calendar-year, Aalb = White-fronted Goose (*Anser albifrons*), Bleu = Barnacle Goose (*Branta leucopsis*)

Date	Place and habitat (and time)	No of ind.	Comments	Observers
24 Apr	Haeska, coastal meadows (10:50–11:30)	2	ad pair, swimming	PT, MLI, AK, RS
24 Apr	Martna, Enivere, feeding on a hay-growing pasture with Aalb and Bleu (20:15–21:50)	12	left towards Haeska after sunset	PT, MLI
25 Apr	Haeska, grazing on coastal meadows (15:30–18:35)	23	in a pure flock	RK, HH, AL, IO, JP, JM etc.
25 Apr	Haeska, a flying flock came from N and flew with other geese towards NNW	16	in another pure flock, arrived from N	RK, HH, AL, IO, JP, JM etc.
25 Apr	Martna, Ehmja, grazing on fields (in the evening)	4	total number in 25 Apr: 43 ind.	RK, JP, JM
26 Apr	Kiideva, flying SE with Aalb 2 (07:45)	2		AL
26 Apr	Haeska, coastal meadows (in the afternoon)	43	a flock of 20 ad + 1 2cy, another flock of 22	HH, RK, AK, AL, RS, PK
26 Apr	between Saastna and Metsküla, grazing on coastal meadows in a flock of Bleu	1	ad, probably not a wild ind.	JP, JM, MT, A.Lotman
27 Apr	Haeska fields, came flying from seashore with Aalb and Bleu (05:45–06:15)	21	same flock as in previous days	AL, PK
27 Apr	Haeska, coastal meadows, maximum count (10:15–20:40)	24	at least flocks of 22 + 2 individuals	HH, RK, AL
28 Apr	Haeska fields, grazing with Aalb 1 (05:45–09:00)	19	same flock as in previous days	HH, RK, AL, MT
28 Apr	Haeska, coastal meadows; maximum count (11:10–16:30)	21	probably including the 19 ind. seen in the morning on the fields; a flying flock of LWfG disturbed by a photographer	HH, RK, AL, MT, PK
29 Apr	Haeska fields, grazing with Aalb 1 (05:50)	22	same flock as in previous days	HH, RK, AL, MT, PK
29 Apr	Haeska, coastal meadows; maximum count (07:00–14:30)	22	same flock as in previous days	HH, RK, AL, MT
30 Apr	Haeska, coastal meadows, grazing in a big flock of Bleu	1	with Swedish colour-rings (= not a wild bird)	MLe
30 Apr	Haeska, coastal meadows; maximum count (05:50–17:15)	20	not including the colour-ringed individual	HH, RK, MLe, MT
30 Apr	Tagavere, N of kolkhoz, flying to NW towards the fields of Uugla with Aalb 4	2		HH, RK, MT
1 May	Haeska, coastal meadows; maximum count (13:30–21:30)	20	same flock as in previous days	HH, RK, MT, VV
2 May	Noarootsi, Tahu coastal meadows (10:35–12:30 and 14:30–18:00)	4	2 ad pairs; probably not seen at Haeska at all	HH, RK, MT
5 May	base of Puise peninsula, in a big flock of Bleu	1	with Swedish colour-rings (= not a wild bird)	PP, JLC
5 May	Haeska, coastal meadows; maximum count (9:30–11:30)	21	same flock as in previous days	PP, JLC
6 May	Haeska, coastal meadows; maximum count; the flock took off and landed in Saardo fields	22	probable LWfG, probably the same flock as in previous days	PP, JLC
7 May	Saardo; a flying flock tried to land at the fields but were scared because of the observers and flew to Haeska	4	2 ad with 2 2cy birds	PP, JLC
8 May	Martna, Putkaste, grazing in a big flock of Bleu	1	with Swedish colour-rings (= not a wild bird)	PP, JLC

5. Discussion

As suggested already before the start of the LWfG monitoring, the surroundings of the Matsalu Bay are definitely a very important spring stop-over site for the Fennoscandian LWfG population. In spring 1999, the total number of LWfG staging in western Estonia was considerably higher as compared with the number of LWfG staging on the Bothnian Bay coast (Timonen 2000, pp. 22–23 in this report) and close to the number counted at the Valdak Marshes (Aarvak & Øien 2000, pp. 24–27 in this report).

The preliminary results of the analyses of the video material (see Aarvak et al. 2000, pp. 32–33 in this report) and colour ring observations (Aarvak et al. 1999) have shown, that at least the main part of LWfG staging in the area belongs to the Fennoscandian population. A major part, if not all, of the birds staging in western Estonia in April–May, stage later in spring also on the Bothnian Bay coast and/or at the Valdak Marshes. The peak number of staging LWfG was noted in the end of April, while on the Bothnian Bay coast the peak was in the period 16–19 May (Timonen 2000, pp. 22–23 in this report) and at the Valdak Marshes between 22 and 25 May (Aarvak & Øien 2000, pp. 24–27 in this report). More research is needed to confirm the importance of western Estonia as an autumn staging area for LWfG, but the results of the 5-days survey trip in September 1999 suggested that the Matsalu area is also a propable autumn stop-over for LWfG.

However, as shown by the observations this year, and also reported e.g. by Pehlak & Lilleleht (1998) and Lilleleht and Leibak (1991), some individuals of reintroduced Swedish origin also use the area for staging. The birds of Swedish reintroduction origin, however, usually occur in the big flocks of Barnacle Geese – which are used as foster parents for them in the reintroduction – and do not seem to mix with the flocks of wild LWfG even when they stage at the same localities.

Clearly, Estonia should be included in the next review of the Action Plan for LWfG conservation (see Madsen 1996) as an important staging area along the migration route of the Fennoscandian population, and annual population monitoring should be given high priority. The coastal meadows of Haeska are included in the highest priority class in the management plan of the coastal meadows of the Matsalu Nature Reserve, and the meadows have been managed by grazing ever since they were lifted up from the sea. At present, the grazing on the meadows is much less intensive than in former times, and two-three times more intensive grazing would be needed to prevent over-growing of the valuable meadows (Leibak & Lutsar 1996).

6. Acknowledgements

Thanks are due to all the field workers and observers mentioned in Table 1. In addition, observations were received from the Estonian Birding Society (Viron lintuseura). The staff of the Matsalu Nature Reserve helped in the arrangements, and Bongariliitto ry funded part of the monitoring work.

References

- Aarvak, T., Øien, I.J., Tolvanen, P. & Markkola, J. 1999:** Two pieces of the spring migration puzzle of the Fennoscandian Lesser White-fronted Goose population in place. In: Tolvanen, P., Øien, I.J. & Ruokolainen, K. (eds.): Fennoscandian Lesser White-fronted Goose conservation project. Annual report 1998. – WWF Finland Report 10 & Norwegian Ornithological Society, NOF Rapportserie Report no 1-1999:27–30.
- Aarvak, T. & Øien, I. J. 2000:** Monitoring of staging Lesser White-fronted Geese at the Valdak Marshes in 1999. In: Tolvanen, P., Øien, I.J. & Ruokolainen, K. (eds.): Fennoscandian Lesser White-fronted Goose conservation project. Annual report 1999. – WWF Finland Report 12 & Norwegian Ornithological Society, NOF Rapportserie Report no 1-2000:24–27.
- Aarvak, T. Timonen, S., Øien, I. J. & Markkola, J. 2000:** Spring migration of Lesser White-fronted Geese in north-western Europe – an analysis from individual markings. In: Tolvanen, P., Øien, I.J. & Ruokolainen, K. (eds.): Fennoscandian Lesser White-fronted Goose conservation project. Annual report 1999. – WWF Finland Report 12 & Norwegian Ornithological Society, NOF Rapportserie Report no 1-2000:32–33.
- Leibak, E. & Lutsar, L. 1996:** Eesti ranna- ja luhaniidud. Estonian coastal and floodplain meadows. – Estonian Fund for Nature and WWF Denmark. Kirjameeste Kirjastus, Tallinn. 247 pp.
- Lilleleht, V. & Leibak, E. 1991:** Rarities in Estonia till 1989 (in Estonian). – *Hirundo* 9:11–26.
- Lilleleht, V. 1999:** Linnuharuldused Eestis 1990–1997. Eesti linnuharulduste komisjoni aruanne. (Rarities in Estonia 1990–1997: report of the Estonian Rarities Committee, in Estonian with English summary) – *Hirundo* 12(2):51–102.
- Madsen, J. (compiler) 1996:** International action plan for the Lesser White-fronted Goose (*Anser erythropus*). – In: Heredia, B., Rose, L. & Painter, M. (eds.) 1996: Globally threatened birds in Europe. Action plans. Pp. 67–78. Council of Europe Publishing, BirdLife International.
- Pehlak, H. & Lilleleht, V. 1998:** Haruldased linnud Lääne-Eestis. Rare birds in the West-Estonia. – *Linnurada* 1/1998:26–33.
- Timonen, S. 2000:** The spring migration of the Lesser White-fronted Geese at the Bothnian Bay in 1999. In: Tolvanen, P., Øien, I. J. & Ruokolainen, K. (eds.): Fennoscandian Lesser White-fronted Goose conservation project. Annual report 1999. – WWF Finland Report 12 & Norwegian Ornithological Society, NOF Rapportserie Report no 1-2000:22–23.
- Tolvanen, P. 1999:** A spring staging area for Lesser White-fronted Geese recovered in Matsalu, Estonia. In: Tolvanen, P., Øien, I.J. & Ruokolainen, K. (eds.): Fennoscandian Lesser White-fronted Goose conservation project. Annual report 1998. – WWF Finland Report 10 & Norwegian Ornithological Society, NOF Rapportserie Report no 1-1999:15–18.

The spring migration of the Lesser White-fronted Goose at the Bothnian Bay in 1999

Sami Timonen

Kosteperäkatu 2 B 12 K, FIN-90100 Oulu, FINLAND, e-mail: sami.timonen@vyh.fi

1. Introduction

The severe world-wide decline of the Lesser White-fronted Goose (*Anser erythropus*, later LWfG) first became apparent in the Fennoscandian population. In Finland, the regular and intensive monitoring started just after the numbers of staging LWfG had decreased to c.100 individuals. The autumn staging as a phenomenon has almost totally disappeared, whereas spring staging LWfG are still seen. After the heavy decline, the only regular staging sites in Finland remain in the low-lying fields with short vegetation along the Bothnian Bay coast.

The year 1999 was the 15th consecutive year with intensive monitoring in the Bothnian Bay by the LWfG working group of WWF Finland. The main results of the monitoring work are summarised in this article.

2. Study area and weather conditions

In 1999, three separate areas were surveyed on the Bothnian Bay coast near Oulu (Figure 1). A detailed description of the study sites is given by Markkola et al. (1998). The Tömpä meadow in Hailuoto has been the most important staging site during the years of LWfG monitoring. In some years in the 1980's, the Säärenperä area has been the best place. The importance of the third area, Liminganlahti Bay, has been gradually decreasing, and at present LWfG are only rarely observed in the area.



Photo. An adult Lesser White-fronted Goose at the Tömpä meadows on Hailuoto, recorded on digital video for individual identification based on the belly patch markings. © Seppo Haapala, May 1999

The weather was exceptionally cold during the first half of May (5°C below the 30-year average), but the temperature rose rapidly (5 degrees) on 16 and 17 May. When the LWfG continued their migration on 19 May the temperature was 5°C above the 30-year average.

3. Methods

The LWfG were observed from permanent hides in Säärenperä and Tömpä. In the Liminganlahti Bay, the geese were searched for by round walks and observing from bird towers. Observations

from the hide succeeded well in Tömpä, whereas in Säärenperä the LWfG were unexpectedly feeding in fields situated 1–2 kilometres from the most regularly used main staging field. Thus, the observations by round walks became the most important method in Säärenperä.

Altogether nine persons participated in the monitoring. The continuous observation period lasted from 5 to 20 May in all observation points.

The attention was mainly paid to video filming of the geese from the hide in Tömpä and from far distance in Säärenperä with a Sony MV 10 video camera with optical magnification up to 16x and a digital magnification up to 64x. The video camera was fixed to the ocular of a telescope (Leica Apo Televid with ocular magnification of 20–60x or 32x). In practice the geese could be filmed from a distance of some hundred metres.

4. Numbers of LWfG in different observation sites

The daily numbers and the total sum of LWfG in the different observation sites are presented in Table 1. Also the number of goosedays and the cumulative sum of individuals are shown. The number of goosedays indicates the preferability of staging place for the geese and the cumulative sum reveals the progress of the migration.

4.1. Tömpä

At the Tömpä meadows in Hailuoto altogether 11 individuals were seen in the period 9–19 May. This is less than at Säärenperä in the nearby mainland area. The length of the staging period, 11 days, was exactly the same as in Säärenperä, and it was continuous (no "empty" days). The peak of the migration took place on 19 May. Three pairs stayed in the fields for 7 days. The number of goosedays was 24 days higher than at Säärenperä. The average staging period per individual was 5.7 days.

4.2. Säärenperä

As in 1998, the LWfG preferred the Säärenperä area. The numbers at this site exceeded those of the Tömpä meadows: altogether 16 LWfG were counted. The peak migration took place 1–2 days earlier than in Hailuoto, and the migration period was two-peaked: 6 LWfG were observed from 10 to 11 May, and the second staging period started after three "empty" days and lasted for five days.

Table 1. Daily numbers of Lesser White-fronted Geese in 1999 in three main observation sites and the cumulative sum of different individuals seen in these places. The final cumulative sum of different individuals per place are shown in the last column. The daily sum of LWfG at all observation points is presented on the last line.

Area / date of May	5	6	7	8	9	10	11	12	13	14	15	16	17	18	19	20	Total
Hailuoto, Tömpä																	
Daily number	–	–	–	–	4	6	6	6	6	6	6	6	4	4	9	–	63 goosedays
Cumulative sum	–	–	–	–	4	6	6	6	6	6	6	6	6	6	11	11	11 ind.
Siikajoki, Säärenperä																	
Daily number	–	–	–	–	–	6	2	–	–	–	2	6	10	8	5	–	39 goosedays
Cumulative sum	–	–	–	–	–	6	6	6	6	6	8	12	16	16	16	16	16 ind.
Bay of Liminganlahti																	
Daily number	–	–	–	–	–	–	–	–	–	–	–	–	–	–	–	–	–
Daily sum of all places	–	–	–	–	4	12	12	12	12	12	14	18	22	22	27	–	

Figure 1. Spring staging areas on the Bothnian Bay coast. The figures inside the circles indicate the number of LWfG seen at each site in spring 1999. For detailed information see the text.



Figure 2. Total numbers of Lesser White-fronted Geese in the Bothnian Bay spring staging areas in the period 1985–1999.

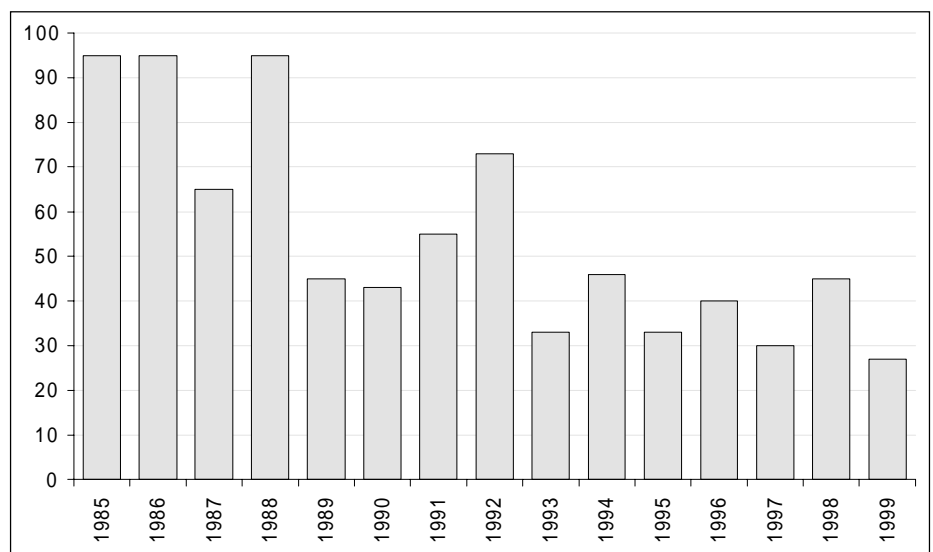

The main fields used by LWfG in Säärenperä were situated southwards from the western cape area, outside the borders of the Nature 2000 conservation area. The reason for this unusual site preference is unclear: it was e.g. assumed that the brand new hide could have scared the geese.

4.3. Liminganlahti and Kraaseli

During the period no LWfG were observed in Liminganlahti Bay.

4.4. Additional observations

As in 1998, the first arriving LWfG was an adult bird flying at the Sannanlahti Bay in the Liminganlahti area on 17 April. LWfG arriving in Finland in early or mid April are commonly considered to be originating from the reintroduction project in Sweden.

5. Discussion

The total number of migrating LWfG, 27 individuals, was the lowest since the start of the monitoring in 1985 (Figure 2). This was unexpected considering the high numbers last year (Timonen 1999) and the high numbers in Estonia earlier this spring (see Tolvanen et al. 2000, pp. 18–21 in this report).

In Tömpä, only one out of three properly identified pairs was found present also in Matsalu, Estonia. None of these three pairs were later observed at Valdak. One out of Säärenperä's four properly

identified pairs was also seen both in Matsalu and at Valdak, and another one only at Valdak (see Aarvak et al. 2000, pp. 32–33 in this report).

References

- Aarvak, T., Timonen, S., Øien, I. J., Tolvanen, P. & Markkola, J. 2000: Spring migration of Lesser White-fronted Geese in north-western Europe – an analysis from individual markings. In: Tolvanen, P., Øien, I. J. & Ruokolainen, K. (eds.): Fennoscandian Lesser White-fronted Goose Conservation Project. Annual report 1999. – WWF Finland Report 12 & Norwegian Ornithological Society, NOF Rapportserie Report no. 1-2000:32–33.
- Timonen, S. 1999: The spring migration of the Lesser White-fronted Goose at Bothnian Bay in 1998. In Tolvanen, P., Øien, I.J. & Ruokolainen, K. (eds.): Fennoscandian Lesser White-fronted Goose conservation project. Annual report 1998. – WWF Finland Report 10 & Norwegian Ornithological Society, NOF Rapportserie Report no. 1-1999:18–20.
- Tolvanen, P., Karvonen, R., Pynnönen, P. & Leito, A. 2000: Monitoring of Lesser White-fronted Geese in western Estonia in 1999. In Tolvanen, P., Øien, I.J. & Ruokolainen, K. (eds.): Fennoscandian Lesser White-fronted Goose conservation project. Annual report 1998. – WWF Finland Report 12 & Norwegian Ornithological Society, NOF Rapportserie Report no. 1-2000:18–21.

Monitoring of staging Lesser White-fronted Geese at the Valdak Marshes in 1999

Tomas Aarvak & Ingar Jostein Øien

Norwegian Ornithological Society (NOF), Seminarplassen 5, N-7540 Klæbu, NORWAY, e-mails: tomas@birdlife.no, ingar@birdlife.no

1. Introduction

Several staging areas for Lesser White-fronted Geese (*Anser erythropus*, later LWfG) existed in Norway until the 1950's, but at present only two areas seems to be important for the small remaining population in the northernmost areas of Fennoscandia. The traditional staging area at Valdak is situated in the Porsangen Fjord in Western Finnmark, and the other, Skjåholmen, which was rediscovered as a staging area in 1994, is situated in the Varangerfjord in eastern Finnmark. Both places are utilised as the last staging area before the onset of breeding and as the first staging area after the moulting period. These two staging areas support geese from two separate breeding areas. The LWfG utilising Valdak breed in western and central Finnmark, while the LWfG staging on Skjåholmen and the surrounding coastal areas in the Varangerfjord breed in eastern Finnmark and northern Finland (Lorensen et al. 1999, own unpublished data). However, it is very likely that the two groups meet during the migration and wintering period, since they utilise the same staging areas during autumn migration (Lorensen et al. 1998).

The Fennoscandian LWfG project run by WWF Finland and NOF has monitored the two staging areas annually since 1995 (Skjåholmen) and 1990 (Valdak) respectively. The results of the monitoring work from October 1998 to November 1999 at the Valdak Marshes is reported in this article, which reiterates all results presented in earlier yearly reports (see Aarvak et al. 1996, 1997, Aarvak & Øien 1999) from the monitoring and research work, but more comprehensive discussions are omitted. This summary is restricted to short comments on the results from 1999. For results of the monitoring work at Skjåholmen, see Tolvanen (2000, pp. 28–31 in this report).

2. Study area and methods

The Valdak Marshes (N 70°09', E 24°54') is a part of the Stabbursnes Nature Reserve, which is a Ramsar site and a BirdLife International Important Bird Area (Norwegian IBA 010; cf. Lislevand et al. 2000). It is one of the largest salt and brackish marshes in northern Norway (Elven & Johansen 1982), and represent an extremely important feeding area for the LWfG in Fennoscandia. The salt tolerant grass *Puccinellia phryganodes* is the staple food for the geese during spring staging. In autumn, they have a much wider diet, comprising *Festuca rubra*, *Puccinella phryganodes*, *Eleocharis uniglumis*, *Agrostis stolonifera*, *Juncus gerardi* and *Elymus arenarius* (Aarvak et al. 1996).

Valdak is demarcated inwards from the fjord by Stabbursnes, which is a headland made up of glacialfluvial depositions. It constitutes of a natural watching point with a height of c. 25 metres above the wet mires and the salt-marshes of Valdak. During the studies, the

observers sit close to the edge of the headland, just beneath the rim, to ensure that their silhouettes can not be seen from beneath. Under such circumstances, the foraging birds can easily be studied at a distance of 250–500 metres without any disturbance to the birds using a telescope (20–60 x magnification).

From 1998 on we have used a new method, by utilising a video-camera (Sony Handycam) to film the geese through the telescope. This method increased significantly the possibilities for accurate individual identification and age determination of the staging geese (Aarvak et al. 1999). By this method it is possible to distinguish subadult pairs from adult pairs, and to more securely separate single subadults from immatures and subadult pairs from adult ones. Subadults are here defined as birds in their third calendar year, while immatures are in their second calendar year (see Øien et al. 1999 about details on ageing).

The aim of the spring monitoring (13 May - 6 June) was to follow the progress of migration and the total number of staging LWfG in the area. As in former years, the individuals were identified by the individual uniqueness of the belly patches. A thorough description of the method is given by Øien et al. (1996). The number of staging individuals and staging time for the pairs (turnover rates) were monitored. In addition, daily activity of individuals and flocks, food preferences, tolerance of disturbance, habitat use, flying activity and migratory movements have been registered.

During autumn (20 August – 5 September) emphasis was put on carrying out counts of families and social groups in order to obtain estimates on brood size, productivity and proportion of immatures in the population. Also during the autumn staging the flocks and individual pairs with goslings were recorded by video-camera.

Since 1995 number of LWfG has been caught, both in Norway, Finland and Russia to map the migration routes by use of satellite telemetry. A few individuals have also been colour-ringed. This has provided further knowledge together with the results obtained by the satellite telemetry (see Aarvak et al. 1999). In autumn 1999 we wanted to catch more geese for colour-ringing. One net covering an area of 1600m² was mounted in the staging period for the geese, but no catching possibilities occurred. The catching attempt was carried out together with the Finnish LWfG Life project.

3. Results

3.1. Spring staging

The first three LWfG arrived during midday and afternoon on 14 May. Thereafter the numbers increased fast on 19 and 20 May,

Table 1. Overview of numbers of Lesser White-fronted Geese at the Valdak Marshes in the springs 1993–99. The table shows the maximum number of staging geese at the best day, distribution of adult pairs, subadult pairs, single subadults, single adults and immatures, as well as total number of staging individuals each spring.

Year	Max on one day	no. of ad pairs	no. of subad pairs	no. of imm	no. of single subadults	no. of single adults	Proportion of imm./single subads	Total no. of ind.
1993	32	32	–	4	–	–	5.9 %	68
1994	24	26	–	4	–	–	7.1 %	56
1995	48	>25	–	>10	–	–	>16.7 %	>60
1996	31	23	–	10	–	–	17.9 %	56
1997	32	26	–	7	–	–	11.9 %	59
1998	37	33	5	5	3	–	21.4 %	84
1999	35	22	3	7 ¹	–	1	25.9 % ²	58

¹ Not included two immatures in pair with adults which is included in the "no. of ad. pairs" column.

² Also included two immatures in pair with adults which is included in the "no. of ad. pairs" column.

reaching a peak of 35 individuals on 23 May. The numbers kept steady around 25 individuals until 25 May (Figure 1). Two pairs and one immature (second calendar-year) bird was still present at the end of the monitoring period on 5 June (Figure 1). Totally 58 individuals were staging at the Valdak Marshes in 1999 (Figure 2), which included 20 adult pairs, 2 pairs of mixed age (one adult and one 2cy), three immature pairs, one single adult and 7 immatures (Table 1). The absolute number of immatures was not very high, but the juvenile proportion was the highest ever since the monitoring began in 1990. In Table 1, percentages of immatures and subadults are given. However, these are not directly comparable to the years 1993–1997 and 1998–1999, since subadults were registered as adults before 1998. The comparable immature percentages for 1998 and 1999 are 6.0 and 12.1 respectively.

In 1999 the mean length of staging period for adult LWfG pairs was 8.0 days (Figure 3), when the pairs already present at the arrival of the field workers and those still left at the departure of the field workers were omitted. We have not tested for differences between years since we have very little data on individual pairs and how their staging time change between years. We have data for more than one year of only one individual LWfG. This is a male which was caught and colour-ringed (colour ring code red-black-yellow) during moult in Finnmark in 1995. It has been observed staging at the Marshes for 10, 6 and 10 days in the years 1996, 1997 and 1998 respectively (see Aarvak & Øien 1999). In 1999, three LWfG colour ringed at the Valdak Marshes in earlier years were seen. An adult female (colour ring code yellow-black) staged 14 days, while an adult male (colour ring code white-black-yellow) staged four days. The last bird with colour rings (code green-white) arrived too late in the period to be followed properly.

3.2. Autumn staging

The year 1999 was the fifth consecutive year when continuous monitoring during the LWfG autumn staging at the Valdak Marshes was accomplished. A total of 43 individuals staged there during a period of three weeks (see Tables 2 and 3). The first single LWfG was seen 16 August. The last observation was at 18:00 on 3 September, when 24 LWfG left the area.

Also in previous years all autumn observations are from the period 16 August to 10 September (1981–1996, see Table 3). This yields a range of 26 days. However, continuous observation effort has been limited to the period from 20 August to the first few days of September in the years 1995 to 1998, and we expect that the actual staging period could start earlier, and in some years it might end later than stated in the table.

The LWfG mainly utilise the area during late evening, night and early morning. They only rarely stay at the marshes during daytime. As experienced in the years 1995–1997, the LWfG behave quite differently compared with the spring staging period, spending more time being alert and showing a restless behaviour. The absence of the LWfG during daytime could partly be caused by

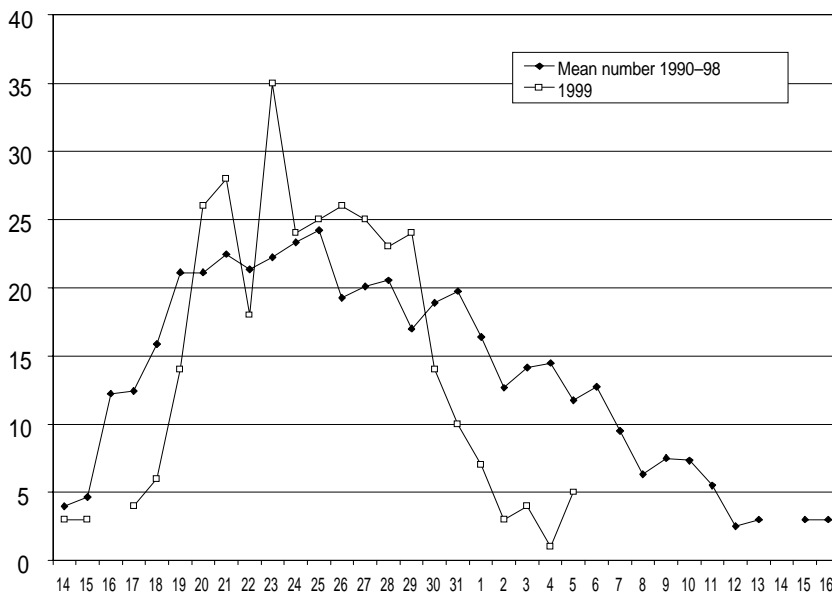

Figure 1. Maximum daily numbers of Lesser White-fronted Geese in the period 14 May – 16 June 1999. Daily means for the years 1993–1998 give an overview of the staging phenology.

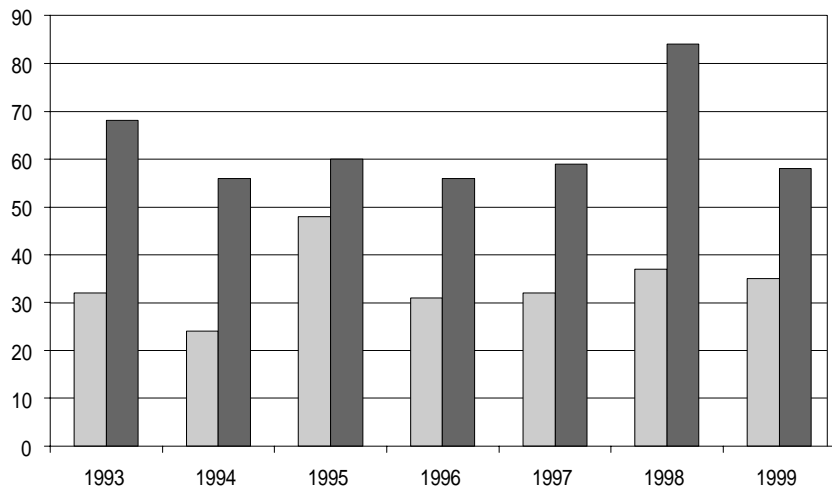

Figure 2. Maximum daily numbers of Lesser White-fronted Geese (light bars) and the total numbers estimated from the drawings of belly patches (dark bars) observed at the Valdak Marshes in the years 1993–1999.

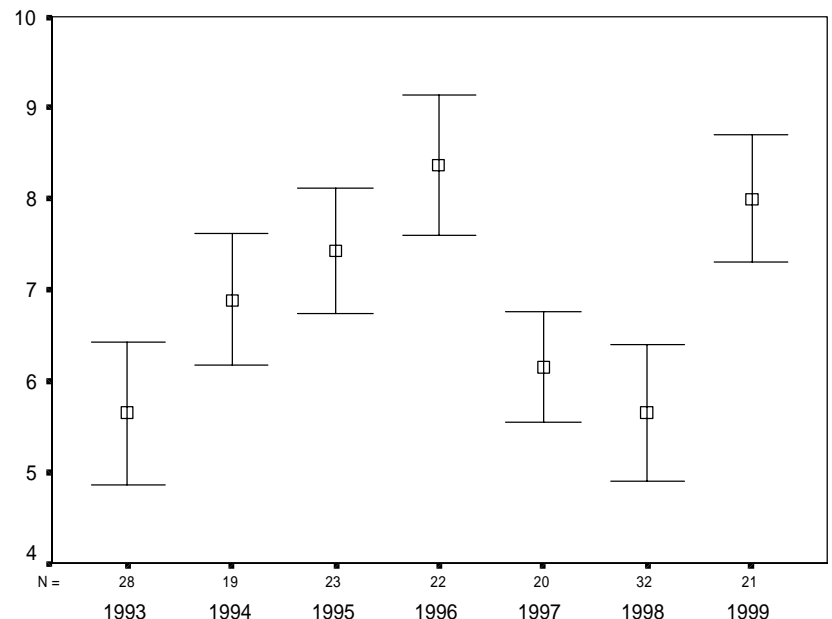

Figure 3. Overview of mean staging time of pairs of Lesser White-fronted Geese at the Valdak Marshes in the years 1993–1999 estimated by the belly patch method (see Øien et al. 1996).



Photo. In spring 1999, 22 adult Lesser White-fronted Goose pairs were staging at the Valdak Marshes, which is 11 pairs less than in the previous year. The picture shows a pair of LWfG at the Valdak Marshes in May 1999. © Ingar Jostein Øien

disturbance from local people picking cloudbberries (*Rubus chamaemorus*). As a result, the geese spend the daytime on the adjacent small islands in the innermost part of the Porsangen Fjord. The LWfG have also been observed on the small islets Kråkholman at the boundary of Stabbursnes Nature Reserve (in 1996) and the northwest point of the Oldereidneset Peninsula (in 1997).

3.3. Breeding success

A total of 26 adults and 17 (40 %) juveniles were registered during the autumn monitoring period. Six pairs brought goslings, yielding a mean brood size of 2.8 (Tables 2 and 4). On the Skjåholmen Island, only one pair with two young were seen (see Tolvanen 2000, pp. 28–31 in this report).

Breeding success is monitored during post breeding period at the Valdak Marshes, which represent the first staging area before the onset of autumn migration. The observations of brood sizes may explain the variation in the breeding success between years. Mean brood size observed at the Valdak Marshes in the years 1994–1999 is as high as 3.2



Photo. During the autumn staging period, the Lesser White-fronted Geese spend more on the islets in the inner part of the Porsangen Fjord than at the Valdak Marshes. © Ingar Jostein Øien, June 1997

Table 2. Autumn age ratio and annual brood sizes of Lesser White-fronted Geese in the years 1981–1999, based on counts during autumn migration at the Valdak Marshes (see also Table 4 for distribution of broods and number of pairs with broods). No data from the years 1982–1986, 1988–1991 and 1993.

Year	n ad	n juv	n total	% juv	n flocks	Mean brood ¹	Mean brood ²	Mean brood ³
1981	10	18	28	64.3	1		3.6	
1987	10	18	28	64.3	1		3.6	
1992	24	34	58	58.6	?		2.8	
1994	31	33	64	*51.6	3	2.4	2.2	1.3
1995	61	67	128	52.3	3	3.9	2.2	2.7
1996	16	23	39	59.0	1	2.6	2.9	1.0
1997	25	32	57	56.1	1	4.0	2.6	1.2
1998	29	31	60	51.6	3–1	2.8	2.4	0.9
1999	26	17	43	39.5	6	2.8	1.3	0.8

¹ Counts of pairs with broods in autumn.

² Number of juveniles divided by number of adults (pairs) in autumn.

³ Number of juveniles in autumn divided by number of pairs in spring.

* Assumed that the observations are from three independent flocks.

Table 3. Overview of the autumn staging period at the Valdak Marshes in the years 1981–1999 (all observations are from the period 16 August – 10 September).

Year	Observation dates (extremes)			Time span in days
	First	Last	Occasional	
1981			17 Aug	(1)
1987			20 Aug	(1)
1992	18 Aug	20 Aug		(3)
1994	17 Aug	10 Sep		25
1995	19 Aug	06 Sep		19
1996	22 Aug	05 Sep		15
1997	20 Aug	03 Sep		15
1998	17 Aug	02 Sep		17
1999	16 Aug	03 Sep		19

($sd=1.4$, $n=58$), although it varies significantly between years (Aarvak et al. 1997). It thus seems that the production is generally high, when based only on the individuals seen on post-moult.

Estimates on brood size can be derived in different ways. Probably, the best estimate is based on the number of juveniles compared with the number of pairs observed (potential breeders) in the pre-breeding period (Mean brood³ - cf. Aarvak et al. 1997), which yields an estimate of 0.8 goslings per potential breeding pair for 1999. This estimated 0.8 goslings fledged per potential breeding pair yield a ratio of 29.3% juveniles in the autumn/winter population based on the number of juveniles produced during summer in relation to all birds that were present at Valdak in spring. For the years 1994, 1995, 1996, 1997 and 1998 we obtained an estimated proportion of 37.1%, 52.8%, 29.1%, 35.2% and 27.0% respectively, with a mean for all years of 35.1% ($sd=9.5$).

Many studies on arctic breeding geese like Barnacle Goose (*Branta leucopsis*), Brent Goose (*B. bernicla*), White-fronted Goose (*Anser albifrons*) and Tundra Bean Goose (*A. fabalis rossicus*) use the age

composition (first-winter individuals and adults) during mid winter counts as a measure of the breeding success of the preceding breeding season (e.g. Ebbinge 1991). In contrast to what we have found in the LWfG, these studies show that the proportion of juveniles varies heavily between 0 and 60% for Brent Goose, 5–30% for Barnacle Goose and 2–50% for White-fronted Goose (Ebbinge 1989, Ebbinge 1991, Fox & Gitay 1989).

Table 4. Distribution of brood sizes (post-moult) at the staging areas of ValdaK Marshes (VM) in 1994–1999, Skjåholmen Island (SI) in the period 1995–1999 and in the breeding grounds in 1994 and 1995. No data exists from the breeding areas in Norway from the years 1996–1999 (see also Table 2).

Year/Area	Brood allocation						Mean size	SD	no. of broods
	1	2	3	4	5	6			
1994									
Breeding area	3	1	1				2.00	1.41	5
Staging area VM		1	2	4			*2.43	0.79	7
1995									
Breeding area	1	1	3	1	2		3.25	1.39	8
Staging area SI		2					2.0	0	2
Staging area VM		4	3	2	6	2	3.94	1.43	17
1996									
Staging area SI					1		5.0	–	1
Staging area VM		1	3	4	1		2.56	0.88	9
1997									
Staging area SI		2	1				2.33	0.58	3
Staging area VM			2	1		5	4.00	1.41	8
1998									
Staging area SI			3				2.0	0	3
Staging area VM		2	4	2	1	1	2.82	1.60	11
1999									
Staging area SI			2				2.00	–	1
Staging area VM		1	1	2	2		2.83	1.12	6

*One flock of 32 individuals (16 goslings) has been omitted, because the distribution of brood sizes is unknown (see also Table 2).

4. Discussion

We have earlier shown that the spring population numbers utilising the ValdaK Marshes decreased by 5% annually in the period 1992–1997, as estimated by Monte Carlo Simulation (Øien et al. 1996, Aarvak et al. 1997). In 1999 the number of (adult and subadult) pairs was the second lowest recorded since the monitoring started in 1990.

The number of juveniles registered during autumn 1999 was very low, and only six out of the 22 adult pairs present during spring successfully produced goslings. This is in line with the observations from Skjåholmen in eastern Finnmark (Tolvanen 2000, pp. 28–31 in this report), indicating a very poor breeding season. We must go back to 1995 to find a very good breeding season for the LWfG in Fennoscandia. For the overall population development, gosling production does not have as significant impact as does adult mortality. As discussed by Aarvak & Øien (1999), it is of vital importance that conservation measures are undertaken to decrease the adult mortality rate for the LWfG population in Fennoscandia. Small changes would most certainly have a significant impact on the population development.

5. Acknowledgements

Many persons have been involved in the project during the period. Special thanks are due to Torkjell Morset at Statskog, Mountain Service in Lakselv for his outstanding logistic and personal assistance during the fieldwork. We would also like to thank Barb Lamprecht Håland and Andreas Tveteraas at Stabbursnes Naturhus og Museum for various help and good co-operation. We are further indebted to Lieutenant Colonel Lyng, Captain Svenningsen and Lieutenant Olsen at the Porsangmoen division of the Norwegian Army for loan of equipment, and to Lieutenant Morten Blom at Banak Air Force Station for various help. From Finland, Risto Karvonen, Ari Leinonen and Petro Pynnönen did a good job during the autumn monitoring period. We are also indebted to Kristine Jacobsen for good work and company, when staying together with us in the field during her studies on behaviour of LWfG. Financial support was provided by the Department of Environmental Affairs – Office of the County Governor of Finnmark and the Directorate for Nature Management, Norway.

References

- Aarvak, T., Øien, I. J. & Nagy, S. 1996: The Lesser White-fronted Goose monitoring programme. Annual report 1996. Klæbu, Norwegian Ornithological Society. NOF Rapportserie. Report no. 7-1996.
- Aarvak, T., Øien I. J., Syroechkovski Jr., E. E. & Kostadinova, I. 1997: The Lesser White-fronted Goose monitoring programme. Annual report 1997. – Norwegian Ornithological Society, Klæbu. NOF Rapportserie. Report No.5-1997. 68 pp.
- Aarvak, T. & Øien, I. J. 1999: Monitoring and catching of staging Lesser White-fronted Geese at the ValdaK Marshes in 1998. - In: Tolvanen, P., Øien, I.J. & Ruokolainen, K. (eds.): Fennoscandian Lesser White-fronted Goose conservation project. Annual report 1998. WWF Finland Report 10 & Norwegian Ornithological Society, NOF Rapportserie Report no. 1-1999:22–27.
- Aarvak, T., Øien, I. J., Tolvanen, P. & Markkola, J. 1999: Two pieces of the spring migration puzzle of the Fennoscandian Lesser White-fronted Goose population in place. - In: Tolvanen, P., Øien, I.J. & Ruokolainen, K. (eds.). Fennoscandian Lesser White-fronted Goose conservation project. Annual report 1998. WWF Finland Report 10 & Norwegian Ornithological Society, NOF Rapportserie Report no. 1-1999:27–30.
- Ebbinge, B. S. 1989: A multifactorial explanation for variation in the breeding performance of Brent Geese *Branta bernicla*. – Ibis 131:196–204.
- Ebbinge, B. S. 1991: The impact of hunting on mortality rates and spatial distribution of geese, wintering in the Western Palearctic. – Ardea 79:197–209.
- Elven, R. & Johansen, V. 1982: Seashore in Finnmark. Flora, vegetation and botanical protection values. Institute of biology and geology, University of Tromsø, report T-541 (In Norwegian with English summary).
- Fox, A. D. & Gitay, H. 1989: Breeding success in Greenland Barnacle Geese *Branta leucopsis* wintering on Islay, Scotland. – Ardea 79:359–364.
- Lahti, K. & Markkola, J. 1995: Ringing recovery of a Finnish Lesser White-fronted Goose from the Russian areas. IWRB Goose Research Group Bulletin, No. 6:27–28.
- Lislevand, T., Folvik, A. & Øien, I. J. 2000: Norway. In: Heath, M. F. & Evans, M. I. (eds.): Important Bird Areas in Europe: priority sites for conservation. Cambridge, UK, BirdLife International Conservation Series No. 8.
- Lorentsen, S.-H., Øien, I. J. & Aarvak, T. 1998: Migration of Fennoscandian Lesser White-fronted Goose *Anser erythropus* mapped by satellite telemetry. – Biological Conservation 84:47–52.
- Lorentsen, S.-H., Øien, I.J., Aarvak, T., Markkola, J., von Essen, L., Farago, S., Morozov, V., Syroechkovsky Jr., E.E. & Tolvanen, P. 1999: Lesser White-fronted Goose *Anser erythropus*. – In: Madsen, J., Cracknell, G. & Fox, A.D. (Eds.) Goose populations of the Western Palearctic. A review of status and distribution. Wetlands International Publ. No. 48, Wetlands International, Wageningen, The Netherlands. National Environmental Research Institute, Rønde, Denmark. Pp. 144–161.
- Øien, I. J., Aarvak, T., Lorentsen, S.-H. & Bangjord, G. 1996: Use of individual differences in belly patches in population monitoring of Lesser White-fronted Goose *Anser erythropus* at a staging ground. – Fauna norv. Ser. C, Cinclus 19:69–76.
- Øien, I. J., Tolvanen, P., Aarvak, T. & Markkola, J. 1999: Occurrence and identification of Lesser White-fronted Goose. – Alula 5:18–23.
- Tolvanen, P. 2000: Monitoring Lesser White-fronted Geese in the Varangerfjord area and eastern Finnmark in 1999. In: Tolvanen, P., Øien, I. J. & Ruokolainen, K. (eds.): Fennoscandian Lesser White-fronted Goose conservation project. Annual report 1999. – WWF Finland Report 12 & Norwegian Ornithological Society, NOF Rapportserie Report no 1-2000:28–31.

Monitoring Lesser White-fronted Geese in the Varangerfjord area and eastern Finnmark in 1999

Petteri Tolvanen

WWF Finland, Lintulahdenkatu 10, FIN-00500 Helsinki, FINLAND, e-mail: tolvanen@sl.fi

1. Introduction

The island Skjåholmen in the bottom of the Varangerfjord (Finnmark, Norway), with the adjacent coastal meadow areas at Veines and Varangerbotn, is one of the two remaining stop-over sites for Lesser White-fronted Geese (*Anser erythropus*, later LWfG) in Fennoscandia during the autumn migration (Tolvanen et al. 1998, Lorentsen et al. 1999). Skjåholmen was identified as a staging area in August–September 1994, when an adult male LWfG tagged with a satellite transmitter in northern Finnish Lapland was located there (Tolvanen et al. 1998). The LWfG staging in the Varangerfjord area are presumed to belong to the part of the Fennoscandian population that breeds in the eastern parts of Finnmark and the northernmost parts of Finland. In addition to the Varangerbotn area (Varangerbotn–Skjåholmen–Veines), LWfG are also known to utilise some other places in eastern Finnmark, especially fields along the shores of the Varangerfjord and the Tana River, and the deltas of the rivers Tana and Neiden.

In 1999, spring monitoring of LWfG in the Varangerfjord area was carried out for the second time, and autumn monitoring for the fifth time.

2. Methods

During spring, three survey trips were carried out, and all the most probable staging places were checked at least once (Table 1, Figure 1). In addition, observations were received from Finnish birders frequently visiting the area. The autumn monitoring on Skjåholmen covered the period 16–27 August, (see Table 1). On Skjåholmen, the geese were observed daily by using two hiding tents to minimise the disturbance for the geese. On the mainland, the northern shoreline of Varangerfjord from Varangerbotn to Vardø was surveyed once (23 August).

3. Results of the spring monitoring

Most of the potential spring staging sites were surveyed, however excluding Skjåholmen Island. The places where LWfG were seen in springtime in 1998 (see Ruokolainen et al. 1999) or 1999 (Sirma fields, Tana Delta/Høyholmen, Nesseby, Ekkerøy/Solnes and Skallelv; see Figure 1) were visited several times.

All observations of LWfG are presented in Table 2. LWfG were seen at four localities (in Nesseby only in flight), but because the individual belly patches were not recorded, the exact total number of observed individuals was not possible to determine. Probably the real number of different individuals was 11–13 birds. The highest single count was 7 individuals (not including the colour-ringed individual seen at Sirma), so the absolute minimum total was 8 birds, and the absolute maximum was 15 individuals, respectively. Among these, no 2nd or 3rd calendar-year birds were reported.

The colour-ringed adult bird seen on Sirma fields in 17 May, continued the migration further to the Valdak Marshes (Porsanger Fjord) where it was seen 18–31 May (see Aarvak & Øien 2000, pp. 24–27 in this report). This individual (yellow-black code on right leg) was ringed 29 May, 1998 at the Valdak Marshes as adult female (Aarvak & Øien 1999), and these were the first reported resightings of it.

4. Results of the autumn monitoring

In mid-summer (29 June, 1999), Finnish birders observed a pair of adult LWfG at the Ekkerøy/Solnes ponds, along E75 road c. 2 km E of the crossroads to Ekkerøy – one of these had green neck band 02 (Eelis Rissanen, pers.comm.). This female (“Enni”) was ringed as breeding adult in Finnish Lapland in July 1995, and has been seen staging on Skjåholmen in August 1995, 1996 and 1997 (Tolvanen et al. 1998), and on the Kanin Peninsula in September 1996 (Tolvanen

Table 1. Schedule of the LWfG monitoring in the Varangerfjord area in 1999 (see also Fig 1). For full names of the observers, see Table 2.

Date	Schedule	Observers
<i>Spring 1999</i>		
17 May	Sirma	MP, PKi, MA
18 May	Sirma – Alletnjarga – Tana Delta/Høyholmen – Nesseby – Karielv – Ekkerøy	MP, PKi, MA
19 May	Nesseby – Varangerbotn – Karlebotn – Veines – Neiden – Ferdesmyra	MP, PKi, MA
20 May	Ferdesmyra – Neiden	MP, PKi, MA
21 May	Neiden – Ferdesmyra – Bugøynes	MP, PKi, MA
22 May	Bugøynes – Varangerbotn – Nesseby – Ekkerøy/Solnes – Skallelv – Kiberg – Vardø	MP, PKi, MA
23 May	Nesseby – Varangerbotn – Veines	MP, PKi, MA
29 May	Sirma – Tana Delta/Høyholmen – Nesseby – Ekkerøy/Solnes	MP, PKi, MA
03 June	Neiden – Munkfjorden – Ferdesmyra – Gukkesgalsjavre	RK, AL, MK
04 June	Gukkesgalsjavri – Coarboeivarri-Reinbogfjellet area	MK
05 June	Ruovdasjavre – Gukkesgalsjavre – Siljuvarri – Garanaskaidi	MK
06 June	Ferdesmyra – Bugøyfjord – Gandvik	MK
07 June	Gandvik – Veines – Karlebotn – Varangerbotn/Meskfjorden – fields along Tana River – Sirma	MK
08 June	Utsjoki – Alletnjarga – Tana Delta/Høyholmen	MK
09 June	Tana Delta/Høyholmen – Varangerbotn/Meskfjorden – Nesseby – Karielv – Ekkerøy – Skallelv	MK
10 June	Skallelv – Kiberg – Vardø – Hamningberg – Ekkerøy	MK
11 June	Ekkerøy – Nesseby – Kvalnes – fields along Tana River – Utsjoki	MK
12 June	Utsjoki – Sirma – Buolmatjavri	MK
13 June	Buolmatjavri area	MK
<i>Autumn 1999</i>		
16 Aug	Varangerbotn	JP, PP, PT
16–27 Aug	Skjåholmen, continuous monitoring	JP, PP, PT
23 Aug	N coastline of Varangerfjord from Varangerbotn to Vardø and back to Nesseby	PP, PT
27 Aug	Skjåholmen – Varangerbotn/Meskfjorden – Neiden, Ferdesmyra	JP, PP, PT



Photo. An adult Lesser White-fronted Goose with two juveniles staging on Skjåholmen. This brood was the only one observed on Skjåholmen in autumn 1999, and had lost another of the parents already before mid-August. In August, the primaries of the breeding adults after the complete moult are not necessarily fully grown. © Petteri Tolvanen, August 1999

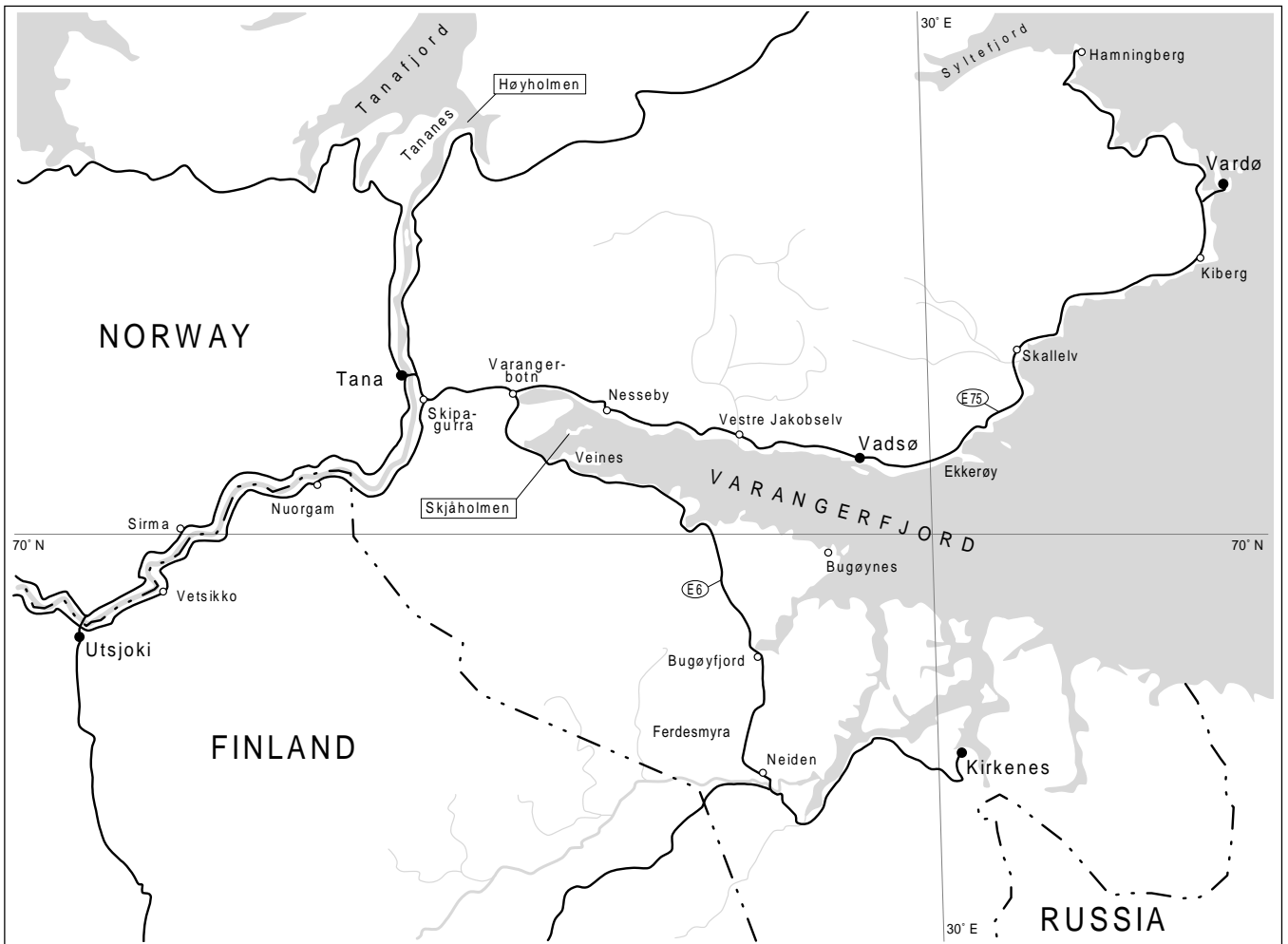

Figure 1. Map of the monitoring area.

Table 2. Observations of Lesser White-fronted Geese in the Varangerfjord area and eastern parts of Finnmark in 1999. Observers: Mika Alava (MA), Risto Karvonen (RK), Pasi Kitti (PKi), Matti Koistinen (MK), Pekka Komi (PK), Ari Leinonen (AL), Maiju Pasanen (MP), Petteri Polojärvi (PP), Jyrki Pynnönen (JP), Eelis Rissanen (ER), Markku Saarinen (MS), and Petteri Tolvanen (PT).

Date	Observations of Lesser White-fronted Geese	Observers
<i>Spring 1999</i>		
14 May	Tana, Sirma fields: 2 ad (not a pair), of which one ind. with Norwegian colour leg rings (yellow-black) in a flock of Bean (<i>Anser fabalis</i>), Pink-footed (<i>A. brachyrhynchus</i>) and Greylag Geese (<i>A. anser</i>) (15:25–17:00)	PK, MS
17 May	Tana, Sirma fields: same 2 ad (not a pair), of which one ind. with Norwegian colour leg rings (yellow-black); in a flock of Bean, Pink-footed and White-fronted Geese (<i>Anser albifrons</i>) (15:45–16:40)	PK, MS; MP, PKi, MA
19 May	Vadsø, Ekkerøy / ponds at Solnes: one adult pair (16:50–18:00)	PK, MS
20 May	Nesseby, Nesseby church: 2 ad flying towards E (07:50–08:35)	PK, MS
20 May	Tana, Sirma fields: 1 unringed ad, left towards Varangerbotn in a flock of Bean and Pink-footed Geese (10:05–10:45)	PK, MS
22 May	Vadsø, Ekkerøy / fields at Solnes: (1 km along E75 road E of the crossroads to Ekkerøy) 7 ind. in a pure flock: 3 ad pairs + 1 single ad; no rings	MP, PKi, MA
29 May	Tana, Sirma fields: 1 ad in a flock of Bean Geese	MP, PKi, MA
08 Jun	Tana, Høyholmen (Tana Delta): adult pair, flew towards NE crossing the delta, circled around the observer and left to E (23:50)	MK
<i>Autumn 1999</i>		
29 Jun	Vadsø, Ekkerøy / Solnes: one adult pair, of which one ind. with green neck band 02 ("Enni", ringed in 1995 in Finnish Lapland)	ER
19–27 Aug	Nesseby, Skjåholmen: 1 ad + 2 juv daily	JP, PP, PT
21 Aug	Nesseby, Skjåholmen: a flock of 5 probably LWfG migrating towards E	PP

1998).

During the autumn monitoring, only one family of one adult and two juvenile LWfG was seen. They were observed for the first time 19 August and stayed on Skjåholmen until the end of the monitoring period (27 August). In addition, a flock of five unidentified small *Anser* geese (probably LWfG) were seen on 21 August migrating towards east along the Varangerfjord. No LWfG were seen on the mainland during the autumn monitoring period.

In August 1999, human disturbance of geese on Skjåholmen was relatively low: a couple of people visited the island for picking of berries, and on some occasions LWfG were scared away from the feeding meadows by them. No hunters were seen on the island during the monitoring period.

5. Discussion

Compared with the autumn staging period, LWfG seem to occur much more scattered in the area in springtime. During the spring staging period 1999, roughly as many LWfG as in spring 1998 were observed in the study area (cf. Ruokolainen et al. 1999). At least the Sirma fields, the Tana river delta (Høyholmen), the Nesseby area (including the in springtime poorly studied Skjåholmen), Ekkerøy area (especially the Solnes ponds with adjacent fields) and the Skallev fields seem to be regular spring staging sites for LWfG. Because the individual belly patches have not yet been recorded in the area during spring, it is not possible to assign if the same birds are using several of these sites, or if observations at one site from different days in fact involves different individuals.

Compared with the previous years (see Figure 2), the total number of LWfG during this autumn monitoring period was clearly the lowest so far, probably again indicating an unsuccessful breeding season in the eastern parts of Finnmark and in northern Finland. The observation of the neck banded female ("Enni") paired with another adult male at Ekkerøy/Solnes on 29 June is another indication of a poor breeding season. Satellite tracking has revealed it is known, that failed breeders can leave Fennoscandia already in mid-summer to moult e.g. on the Kanin Peninsula or other parts of arctic Russia (Aarvak et al. 1997).

During the autumn staging period, the island Skjåholmen has proved to be the most important site for LWfG in the Varangerfjord area, – e.g. in August 1999 LWfG spent the whole monitoring time on the island. Despite being one of the only two remaining important

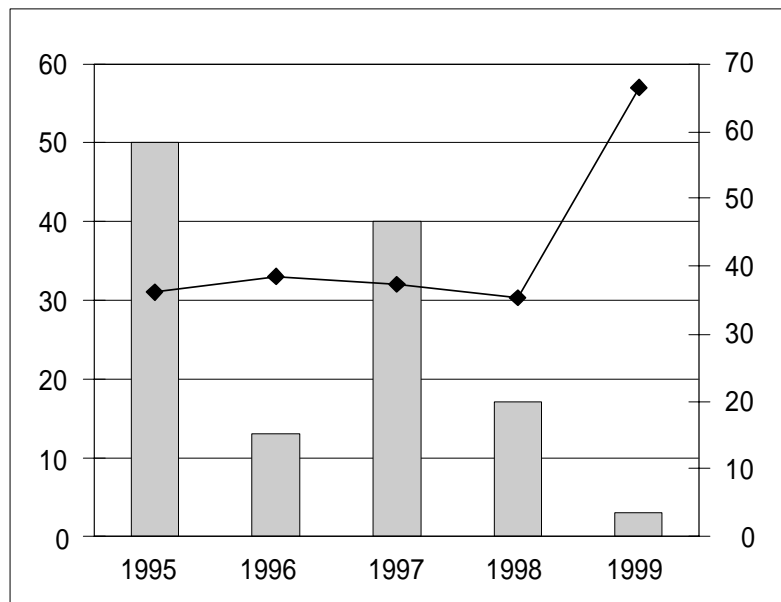

Figure 2. Total numbers (minimum estimates) of LWfG staging in the study area during the autumn monitoring period in 1995–1999 (bars, scale on the left side) and respective juvenile percentages (line, scale on the right side).

autumn staging areas for the Fennoscandian LWfG, Skjåholmen still remains unprotected, and there are no restrictions for human activities like berry picking, hiking or even hunting during the staging periods of LWfG. Protection is urgently needed at least for the staging periods (15 May–15 June and 15 August–15 September). Fortunately – possibly partly due to the monitoring activity on the island – the human disturbance on geese on Skjåholmen was low also in August 1999.

In a meeting with Steinar Schanche, Fylkesmannen i Finnmark, Miljøvernavdelingen (County Governor of Finnmark, Environmental Department) on 23 August, 1999, LWfG conservation issues in the Varangerfjord area were discussed. According to S. Schanche, a ban for hunting on Skjåholmen could be achieved in the near future.

6. Acknowledgements

Thanks are due to all the people who took part in the monitoring. Einar Roska from Nesseby kindly rescued the autumn monitoring team back to mainland after a motor breakdown, and Steinar Schanche helped in the arrangements. The autumn monitoring was

Photo. An adult Lesser White-fronted Goose (same individual as in the photo on p. 29) on Skjåholmen, recorded on digital video for individual identification based on the belly patch markings. © Petteri Tolvanen, August 1999



for the first time funded by the Forest and Park Service and conducted by the Finnish LWfG project.

References

- Aarvak, T., Øien, I. J., Syroechkovski Jr, E. E. & Kostadinova, I. 1997:** The Lesser White-fronted Goose Monitoring Programme. Annual report 1997. – Klæbu, Norwegian Ornithological Society. NOF Rapportserie, Report no. 5-1997.
- Aarvak, T. & Øien, I. J. 1999:** Monitoring and catching of staging Lesser White-fronted Geese at the Valdak Marshes in 1998. In: Tolvanen, P., Øien, I.J. & Ruokolainen, K. (eds.): Fennoscandian Lesser White-fronted Goose conservation project. Annual report 1998. - WWF Finland Report 10 & Norwegian Ornithological Society, NOF Rapportserie Report no 1-1999: 22–27.
- Aarvak, T. & Øien, I. J. 2000:** Monitoring of staging Lesser White-fronted Geese at the Valdak Marshes in 1999. In: Tolvanen, P., Øien, I.J. & Ruokolainen, K. (eds.): Fennoscandian Lesser White-fronted Goose conservation project. Annual report 1999. – WWF Finland Report 12 & Norwegian Ornithological Society, NOF Rapportserie Report No 1-2000: 24–27.
- Lorentsen, S.-H., Øien, I. J., Aarvak, T., Markkola, J., von Essen, L., Faragó, S., Morozov, V., Syroechkovski Jr., E. E. & Tolvanen, P. 1999:** Lesser White-fronted Goose Anser erythropus. In: Madsen, J., Cracknell, J. & Fox, T. (eds): Goose Populations of the Western Palearctic. A review of status and distribution. – Wetlands International Publ. No. 48. Wageningen, The Netherlands. National Environmental Research Institute, Rønde, Denmark. Pp. 144–161.
- Ruokolainen, K., Tolvanen, P. & Kaartinen, R. 1999:** Monitoring Lesser White-fronted Geese in the Varangerfjord area in 1998. In: Tolvanen, P., Øien, I.J. & Ruokolainen, K. (eds.): Fennoscandian Lesser White-fronted Goose conservation project. Annual report 1998. - WWF Finland Report 10 & Norwegian Ornithological Society, NOF Rapportserie Report no 1-1999: 31–35.
- Tolvanen, P. 1998:** Lesser White-fronted Goose Anser erythropus expedition to the Kanin Peninsula in 26 August – 12 September, 1996, and the establishment of the Shoininsky Reserve. In: Tolvanen, P., Ruokolainen, K., Markkola, J. & Karvonen, R. (eds.). Finnish Lesser White-fronted Goose conservation project. Annual report 1997. – WWF Finland Report 9: 33–35.
- Tolvanen, P., Pynnönen, J. & Ruokolainen, K. 1998:** Monitoring of Lesser White-fronted Goose Anser erythropus on Skjåholmen (Varangerfjord, Finnmark, Norway) in 1995–1997. In: Tolvanen, P., Ruokolainen, K., Markkola, J. & Karvonen, R. (eds.): Finnish Lesser White-fronted Goose conservation project. Annual report 1997. – WWF Finland Report 9: 30–32.

Spring migration of Lesser White-fronted Geese in north-western Europe – an analysis from individual markings

Tomas Aarvak¹, Sami Timonen², Ingar Jostein Øien¹, Petteri Tolvanen³ & Juha Markkola⁴

¹Norwegian Ornithological Society (NOF), Seminarplassen 5, N-7540 Klæbu, NORWAY, e-mails: tomas@birdlife.no, ingar@birdlife.no

²Kosteperänkatu 2 B 12 K, 90100 Oulu, FINLAND, e-mail: sami.timonen@vyh.fi

³WWF Finland, Lintulahdenkatu 10, FIN-00500 Helsinki, FINLAND, e-mail: tolvanen@sl.fi

⁴North Ostrobothnia Regional Environment Centre, P.O. Box 124, FIN-90101 Oulu, FINLAND, e-mail: juha.markkola@vyh.fi

1. Introduction

In 1998, we were able to document that Lesser White-fronted Geese (*Anser erythropus*, later LWfG) utilising spring staging areas in Estonia, Finland and northern Norway were mainly the same individuals. This was achieved by comparing videotapes and belly patch drawings from the Valdak Marshes in spring 1998 with photos and belly patch drawings made during spring 1998 on the Bothnian Bay coast in Finland. Roughly calculated, 75% of the LWfG staging at the Bothnian Bay coast migrated further to the Valdak Marshes. This was also supported by the appearance of the same colour-ringed individual in both areas in spring 1998 (Aarvak et al. 1999). This individual was also observed in Haeska, Matsalu, W Estonia a few days prior to the observation in Finland (Aarvak et al. 1999). In 1999 we extended the use of video equipment to follow individuals and pairs already from the staging area in Estonia to obtain a better understanding of the numbers and structure of the Fennoscandian breeding population.

2. Methods

Øien et al. (1996) describe how the unique pattern of belly patches is used to follow the LWfG population staging at the Valdak Marshes. In Valdak all geese are drawn on ready-made sheets to provide a reliable estimate of the number of LWfG using the area. To create a more accurate archive of the individuals we have started to film the geese by video camera (Sony Handycam) mounted on a telescope (Swarovski AT 80 HD with 20-60 x zoom ocular) at the Valdak Marshes. This combination enables us to videotape the geese at much longer distances than would otherwise be possible with photographic equipment (cf. Aarvak et al. 1999). On the Bothnian Bay coast and in Estonia, a digital video camera (Canon MV10) mounted on a telescope (Leica Apo Televid with 20xW and 20-60 x zoom oculars) was used in the spring 1999. The main purpose was to improve the identification of individuals and pairs and ageing, and finally to reveal migratory movements and life history of individuals by comparing the belly patches on the videotapes from these three staging sites. Two examples of digital video images from the year 1999 (one from the Bothnian Bay coast, recorded in May; and one from Skjåholmen, Varangerfjord, recorded in August) are shown in this report, see pp. 22 and 31.

In Estonia, continuous monitoring was carried out from 23 April to 12 May (Tolvanen et al. 2000, pp. 18–21 in this report), on the Bothnian Bay coast in the period 5 May to 20 May (Timonen 2000, pp. 22–23 in this report) and at the Valdak Marshes in the period 13 May – 6 June (Aarvak & Øien 2000, pp. 24–27 in this report).

3. Results

In total, 13 out of estimated 27 geese were filmed in the Bothnian Bay area. This excludes about half of the geese from the comparison. In Estonia most of the geese were filmed, but due to general low quality of the tapes, only eight pairs and two single males could be readily identified by their belly patch pattern. Out of the 43–51 LWfG seen in Estonia (Tolvanen et al. 2000, pp. 18–21 in this report), six pairs and two males arrived at Valdak. One of the males seemed to be unpaired in Estonia, but at Valdak he was paired with a female

that was colour-ringed at the same site in 1997 (colour leg ring code: White-Black-Red). Whether this male later found a partner along the route or was paired already in Estonia is unknown. One of the pairs divorced at Valdak, but both individuals mated with other mates after two days at the Valdak Marshes. All the six pairs and two single male LWfG that were identified from the video tapes from both Estonia and Valdak, arrived at the Valdak Marshes during the relatively short time span between 19 and 23 May. At the Valdak Marshes, the first LWfG pair was seen 14 May, while the last pair arrived as late as 5 June (Aarvak & Øien 2000, pp. 24–27 in this report). At the Valdak Marshes, 21 pairs out of the estimated total of 25 adult and subadult pairs were filmed. However, in practise all LWfG observed, excluding juveniles, were identified due to exact belly patch drawings.

Only one of these pairs was also positively identified at Säärenperä on the Bothnian Bay coast. In addition to these birds, one more pair seen at the Bothnian Bay coast (Säärenperä) was also seen staging at the Valdak Marshes.

Out of the pairs identified in the Matsalu area, two pairs were not seen at the Valdak Marshes. Similarly four pairs and one single bird of the LWfG identified in the Bothnian Bay area were not seen later at the Valdak marshes, showing that not all pairs migrate to the Valdak Marshes and further to the core breeding area in Norway.

4. Discussion

The videotapes and belly patch drawings collected from Estonia, Finland and Norway in 1999 confirmed the results from 1998, that the LWfG using these areas are mainly the same individuals.

Unfortunately, in Finland it was not possible to obtain high-quality videotape of the filmed individuals, and half of the observed geese could not be filmed at all because the LWfG mostly staged too far from the observers and in the mudflats at Säärenperä.

In addition some methodological problems in Estonia made it impossible to gain reliable data on which birds migrate to the different staging sites in Fennoscandia. Only further work in the coming years will unveil this. At the Valdak Marshes it seems that the LWfG arrive via two different routes, because a bimodal distribution of LWfG numbers can be seen in some of the years where monitoring has been conducted at the Valdak marshes (see Aarvak & Øien 2000, pp. 24–27 in this report; Aarvak & Øien unpublished data). The lack of this bimodal distribution does, however, not preclude the existence of a population with mixed migratory behaviour. A more detailed analysis of the material and observations of colour ringed individuals are necessary.

Since the LWfG positively identified in Estonia this spring arrived at the Valdak Marshes during a relatively short time period in May, we suggest that there might be two sub-groups of LWfG using the Valdak Marshes almost simultaneously. Results obtained by the use of satellite transmitters have shown that there are in fact two different migration routes during autumn (see Lorentsen et al. 1997), but whether these birds return along a common spring migration route is at present unknown.



Photo. Ingar Jostein Øien recording geese on video tape using a video camera mounted on a telescope. © Petteri Tolvanen, 1999

5. Acknowledgements

We appreciate the monitoring work carried out by a number of field workers at the Bothnian Bay coast and in Estonia. Details about this work and acknowledgements to the observers are given by Tolvanen et al. 2000 (pp. 18–21 in this report) and Timonen 2000 (pp. 22–23 in this report). The video filming was, in addition to the authors, carried out by Risto Karvonen and Heikki Holmström in Estonia, Seppo Haapala at Hailuoto, Tömpä and Risto Karvonen at Siikajoki, Säärenperä in Finland. We really appreciate their effort and enthusiasm.

References

- Aarvak, T. & Øien, I.J. 2000:** Monitoring of staging Lesser White-fronted Geese at the Valdak Marshes in 1999. In: Tolvanen, P., Øien, I. J. & Ruokolainen, K. (eds.): Fennoscandian Lesser White-fronted Goose conservation project. Annual report 1999. – WWF Finland Report 12 & Norwegian Ornithological Society, NOF Rapportserie Report no 1-2000:24–27.
- Aarvak, T., Øien, I.J., Tolvanen, P. & Markkola, J. 1999:** Two pieces of the spring migration puzzle of the Fennoscandian Lesser White-fronted Goose population in place. In: Tolvanen, P., Øien, I. J. & Ruokolainen, K. (eds.): Fennoscandian Lesser White-fronted Goose conservation project. Annual report 1998. WWF Finland Report 10 & Norwegian Ornithological Society, NOF Rapportserie Report no. 1-1999:27–30.
- Lorentsen, S.-H., Øien, I.J. & Aarvak, T. 1998:** Migration of Fennoscandian Lesser White-fronted Geese *Anser erythropus* mapped by satellite telemetry. – *Biological Conservation* 84:47–52.
- Øien, I.J., Aarvak, T., Lorentsen, S.-H. & Bangjord, G. 1996:** Use of individual differences in belly patches in population monitoring of Lesser White-fronted Goose *Anser erythropus* at a staging ground. – *Fauna norvegica Series C, Cinclus* 19:69–76.
- Timonen, S. 2000:** The spring migration of the Lesser White-fronted Goose at the Bothnian Bay in 1999. In: Tolvanen, P., Øien, I. J. & Ruokolainen, K. (eds.): Fennoscandian Lesser White-fronted Goose conservation project. Annual report 1999. – WWF Finland Report 12 & Norwegian Ornithological Society, NOF Rapportserie Report no 1-2000:22–23.
- Tolvanen, P., Karvonen, R., Pynnönen, P. & Leito, A. 2000:** Monitoring of Lesser White-fronted Geese in western Estonia in 1999. In: Tolvanen, P., Øien, I. J. & Ruokolainen, K. (eds.): Fennoscandian Lesser White-fronted Goose conservation project. Annual report 1999. – WWF Finland Report 12 & Norwegian Ornithological Society, NOF Rapportserie Report No 1-2000:18–21.

Field surveys in possible breeding areas of Lesser White-fronted Goose in Lapland and Finnmark

Jarmo Pääläinen & Sami Timonen

North Ostrobothnia Regional Environment Centre, PO BOX 124, FIN-90101 OULU, FINLAND, e-mails: jarmo.paalainen@vyh.fi, sami.timonen@vyh.fi

1. Introduction

The field work in Lapland in summer 1999 was divided in three different parts: surveys in the potential breeding grounds of Lesser White-fronted Goose (*Anser erythropus*, later LWfG); limiting the Red Fox population; and offering additional food for geese. The work was concentrated in the most potential breeding areas based on knowledge from earlier years, and was carried out as a part of the Finnish LWfG Life project.

The surveys were carried out by 12 survey groups formed by 23 persons, equivalent to about 10 months field work. The surveyed area covered c. 2000 km² in Finland and c. 500 km² in Norway. Like in earlier years, the teams were in the field from 2 to 20 June, and again from 20 to 10 August, leaving the incubating and hatching period of LWfG without human disturbance.

The surveys in Norway were carried out by three survey teams and the areas were chosen based on earlier observations near the Finnish border and in the eastern and western parts of Finnmark.

The teams collected all goose feathers found in the field, and compared them with a LWfG feather formula specially made for this purpose to verify the identification. Also, faeces of geese were collected for later DNA analysis. Suitable LWfG breeding habitats were photographed in order to analyse possible landscape changes. A team visiting the core breeding area used a videocamera for this purpose.

2. Weather conditions

The snow layer was exceptionally thick due the cold temperatures in May and June, and when it melted rapidly the flood was huge, complicating the field work. In July and August the surveys were difficult due to heavy rain.

3. Observations

In June, a flock of five LWfG (probably moulting or migrating non-breeders) was seen in Kevo Strict Nature Reserve in northern Finnish Lapland. In the core area, where LWfG were breeding at least until 1995, one small unidentified goose (possibly LWfG) was seen flying with a Bean Goose (*Anser fabalis*). During the pre-nesting period two LWfG (not a pair) were observed in the fields of Sirma by the Tana River (see Tolvanen 2000, pp. 18–22 in this report). A flock of six LWfG (flying north, possibly landing on a lake) was seen in the former Finnish core breeding area by a frontier guard on 24 September.

Less Bean Geese and Whooper Swans (*Cygnus cygnus*) were observed in 1999 as compared with 1998. Some individuals of Pink-footed Goose (*Anser brachynchus*) and White-fronted Goose (*A. albifrons*) were observed during the surveys.

On the Norwegian side, only one flock of six LWfG was observed flying north on 1 July in western Finnmark.

4. Limiting the Red Fox population

The population of Red Fox (*Vulpes vulpes*) has increased gradually in the last decades in northern Finnish Lapland. The data collected since 1989 in the former Finnish core breeding area of LWfG indicates that the abundance of Red Foxes may significantly limit the annual reproduction of the geese. Most of the geese seem to give

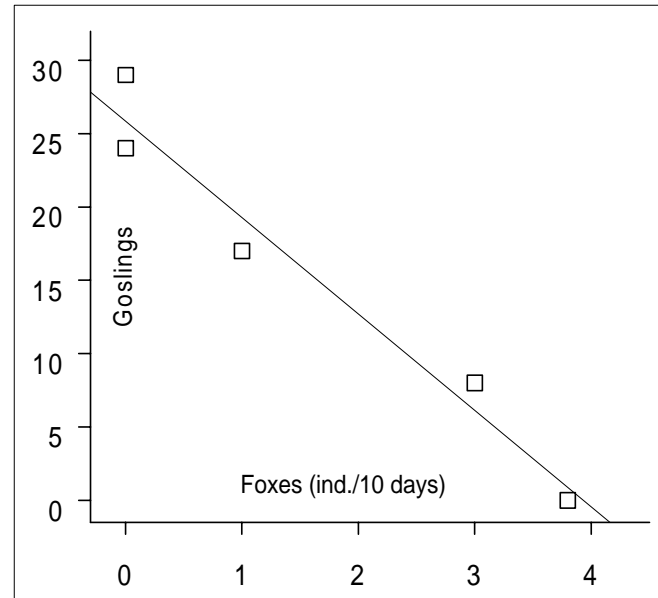

Figure 1. Linear regression indicating the negative correlation between the number of produced LWfG goslings and the number of Red Foxes seen per ten observation days ($p < 0.01$). Each plot represents one of five consecutive years 1989–1993.

up breeding in years when foxes are abundant (Figure 1).

In the winter 1998–99, Red Foxes were hunted with snowmobiles by a special permission for the conservation of the endangered Arctic Fox (*Alopex lagopus*) and LWfG populations. The hunting bag in 1999 was altogether 112 Red Foxes, while the total bag during the last three winters has been c. 300. All foxes were sent to the Veterinary and Food Department (EELA) of the Finnish Ministry of Agriculture and Forestry for further studies.

5. Offering additional food to improve gosling production

A good nutritional status of females is known to improve the egg production in geese. In Finnish Lapland, additional food for geese was offered as a part of the Finnish LWfG Life project. In 1999, the food was supplied only in the former core breeding area of LWfG in some marsh areas, river deltas and lake shores. The feeding sites were checked regularly during two weeks in spring. Bean Geese were seen abundantly feeding on the barley, but no LWfG were observed.

References

Tolvanen, P. 2000: Monitoring Lesser White-fronted Geese in the Varangerfjord area and eastern Finnmark in 1999. – In: Tolvanen, P., Øien, I. J. & Ruokolainen, K. (eds.): Fennoscandian Lesser White-fronted Goose conservation project. Annual report 1999. – WWF Finland Report 12 & Norwegian Ornithological Society, NOF Rapportserie Report no 1-2000:28–31.

Surveys for Lesser White-fronted Goose in the Bolshezemelskaya Tundra, European Russia, in 1999

Vladimir V. Morozov

Russian Research Institute for Nature Protection, Znamenskoye-Sadki, Moscow 113628, Russia & Zoological Museum of Moscow State University, Bolshaya Nikitskaya St., 6, Moscow 103009, RUSSIA, e-mail: morozov@l.zoomus.bio.msu.ru

1. Introduction

The numbers of Lesser White-fronted Goose (*Anser erythropus*, later LWfG) and its range have declined seriously throughout recent decades and this process is going on all over the species range. The once continuous breeding range of the species is at present split into several isolated areas. Twenty years ago the world population was estimated at about 130,000 individuals (Vinogradov 1990), but such high estimates is considered to have been too high (e.g. Rogacheva 1992). Currently, the western (European – central Siberian) LWfG populations are estimated at ca. 8,500–17,000 individuals (Lorentsen et al. 1999). LWfG is included in the list of threatened waterfowl species (Tucker & Heath 1994), and it has been enlisted in the second edition of the Red Data book of the Russian Federation as a species of status II (Vulnerable).

Recently it has been suggested that several geographically separated breeding populations of LWfG exist, with different wintering grounds and migration routes (Morozov 1995). Results from studies carried out by the Wetlands International LWfG Task force in different parts of the LWfG breeding range (Aarvak et al. 1997, Morozov & Kalyakin 1997, Karvonen & Markkola 1998, Lorentsen et al. 1998, Øien et al. 1999) confirmed this suggestion.

Within Russia, the population inhabiting European tundras is the most vulnerable. According to estimations made 10 years ago, it does not exceed a total of 500–1,000 birds. In the eastern part of Bolshezemelskaya Tundra, only 125 adults were counted (Morozov

1988). The data collected in the period 1993–1995 have indicated extinction of the LWfG in many sites of this region (Morozov 1995).

Besides being the most vulnerable, the population of the European tundras of Russia remains one of the least known ones. Recently published information on genetic structure exist for the Fennoscandian and Yamal populations of LWfG. The genetic structures of these populations are very different, but we still lack knowledge on genetic structure, migration routes, wintering grounds and present status of the LWfG population of Bolshezemelskaya Tundra between the two subpopulations of Fennoscandia and Yamal. Data on genetic structure of the LWfG population in this region is important since it occupies the territory between the breeding areas of the Fennoscandian and Yamal LWfG populations.

The existing information on the LWfG population of European tundras of Russia is obviously insufficient to implement effective conservation measures for this population on the breeding grounds. Therefore, a pilot project to clear up the present status of the LWfG population of the Bolshezemelskaya Tundra was initiated.

The main aim of the survey was to outline the recent breeding grounds, to estimate the numbers and to find staging areas for the European LWfG population in Russia. In accordance with this final goal the following objectives should be pursued:

- check breeding sites that were not checked for 10 years;
- estimate breeding numbers;
- catch LWfG for marking with neckbands and colour leggrings;



Photo 1. Landscape view of the Bolshaya Rogovaya River basin area. © Vladimir Morozov, 1999



Photo 2. Landscape view of the Polar Ural area. © Vladimir Morozov, 1999

- study breeding biology, productivity, habitat preferences and moult patterns;
- collect feathers and blood samples for genetic analyses.

2. Study areas

The study was carried out in the eastern part of Bolshezemelskaya Tundra and the Polar Ural mountains, where LWfG were observed in the period 1984–93 (Morozov 1988, 1995). The study area is located in the southern tundra subzone within 67°30'–68°30' N, 60°00'–70°00' E. It encompasses the basins of Bolshaya Rogovaya River and foothills of the Polar Ural. Co-ordinates of the Bolshaya Rogovaya River basin are 67°25'–67°36' N, 62°01'–62°30' E, and for Polar Ural areas: 67°02'–67°28', N, 63°55'–65°10' E.

The landscape of the lowland tundras of Bolshaya Rogovaya River basin is hilly, and watersheds are usually flat and considerably swampy (Photo 1). Profusely meandering rivers occupy deep valleys and sometimes form steep slopes. Rivers flow usually slowly, and sandy or muddy banks prevail. In the watersheds there is a great number of lakes of different origin.

The landscape of the Polar Ural is typically mountainous (Photo 2). Watersheds in foothills are drier than those of lowland tundras. There are practically no lakes and areas dominated by mires are scarce. Rivers are of mountain character with rapid flow, stony bottoms and banks composed of rocks. Some river valleys form narrow canyons. The vegetation in the lowland tundra is similar to the vegetation in the mountains. Shrub tundras and dense bushes prevail everywhere within the study area. In these types of tundras, dwarf birch (*Betula nana*) and willows (*Salix lanata*, *S. glauca*, *S. phyllicifolia* and *S. lapponum*) dominate. The shrubs reach 50–60 cm in height, and dense bushes of more than 2 m high grow along river and stream valleys. On the flood-plains there are small sedge and grassy meadows.

3. Weather conditions

In general 1999 was characterised by cold and wet weather. The

spring came late, and in early June 80% of the area was covered by snow. Regularly the temperature fell below 0°C. It was snowing practically every day, and frost at night occurred daily. By mid June, about 50% of the area was covered by snow. Due to a very cold winter, many rivers were frozen to the bottom. Drifting of ice observed 7–15 June, occurred only in large rivers, in small ones the water flowed on top of the melting ice. The lakes became ice-free after 5 July.

The summer was cool, cloudy and rainy. From 1 July to 20 August only 20 days were without precipitation. Strong rain showers in August caused short time floods in the mountains and foothills. In total the breeding conditions were not favourable. Bean Geese started to breed late, the broods had few goslings and the percentage of non-breeding birds was relatively high. Apparently LWfG did not breed in one of the investigated areas because of the unfavourable weather conditions.

4. Methods

Transportation. Since the distance between the two study areas was more than 150 km, we rented a caterpillar truck, by which our team moved from Vorkuta to both study areas. During the spring flooding we used motorboat. In summer, when rivers became shallow, a rubber boat was used to drive along the large rivers (Usa and Bolshaya Rogovaya rivers). In the foothills of the Polar Ural we went by foot.

Counts. We counted geese in order to reveal present distribution and numbers of LWfG within the study area. In the Usa and Bolshaya Rogovaya River valleys, the geese were counted by using motorboat in spring and rubber boat in summer. One field worker went by boat along the stream while two others moved by foot along each river bank. Watersheds and small streams were surveyed by walking. Attention was paid to traces of geese (footprints, feathers, excrements, grazing sites). The total length of the boat censuses was 320 km, and for counts by foot 440 km. The surveyed area in the Bolshaya Rogovaya River basin totalled 400 km², and the one in Polar Ural 950 km². The surveyed area of the foothills of Polar Ural was 450

km², and the surveyed area of the mountains was approximately 500 km². Since LWfG do not inhabit interior part of the mountains, the population density was estimated only for the foothills. In order to estimate the population density of LWfG, we plotted on maps the location of broods and groups of non-breeding birds. Densities were calculated for a 100 km² area. We used maps in the scale 1:100,000 and 1:500,000.

Catching. The geese were caught in July and August when adults were moulting. Different ways of catching were applied. Usually, LWfG family was chased to the shore and caught by hoopnets or by hand on the river banks. Diving geese were caught by hoopnets or by hand. We took blood samples from every caught bird and put in a tube with buffer. Goslings weighing more than 400 g were supplied with standard metal ring. We planned to mark adult geese with red neck-bands, but we caught no adults. The goslings we caught were too young to mark with neck-bands. Data on breeding sites, breeding biology, habitat preferences and moult was collected.

5. Results

Distribution. In comparison with 1983–1987, the distribution of LWfG in the the Polar Ural mountains had not changed considerably (Figures 1 and 2). Also in the Bolshaya Rogovaya River basin LWfG inhabited the same places as during the first survey.

Numbers. In total 81 LWfG (46 adults and 35 juveniles) were counted in the investigated areas. In the Bolshaya Rogovaya River basin, 21 adult individuals in two groups were found occupying different sites (Figure 3). Thus, nine of them were registered in the Bolshaya Rogovaya River valley, where the river crosses Tyulissemussyur upland, 12 LWfG were found in the Syatteityvis stream which is the a tributary of the Bolshaya Rogovaya River. The total population density in lowland tundras is estimated at 5.25 ind./100 km². As for the Polar Ural several breeding sites of LWfG were found (Figure 2). Breeding density was estimated at 2.07 pairs/100 km², while population density was estimated at 6.67 ind./100 km².

Habitats. LWfG were only found in the river valleys only. In watersheds, tundra and lakes they were not observed. In June, feeding birds were also found in swamps. Later, however, in the brooding and moulting period, Lesser White-fronts were not observed there. The preferred habitats both in lowland tundra and foothills tundra were the river valleys sites with steep banks alternating with bush

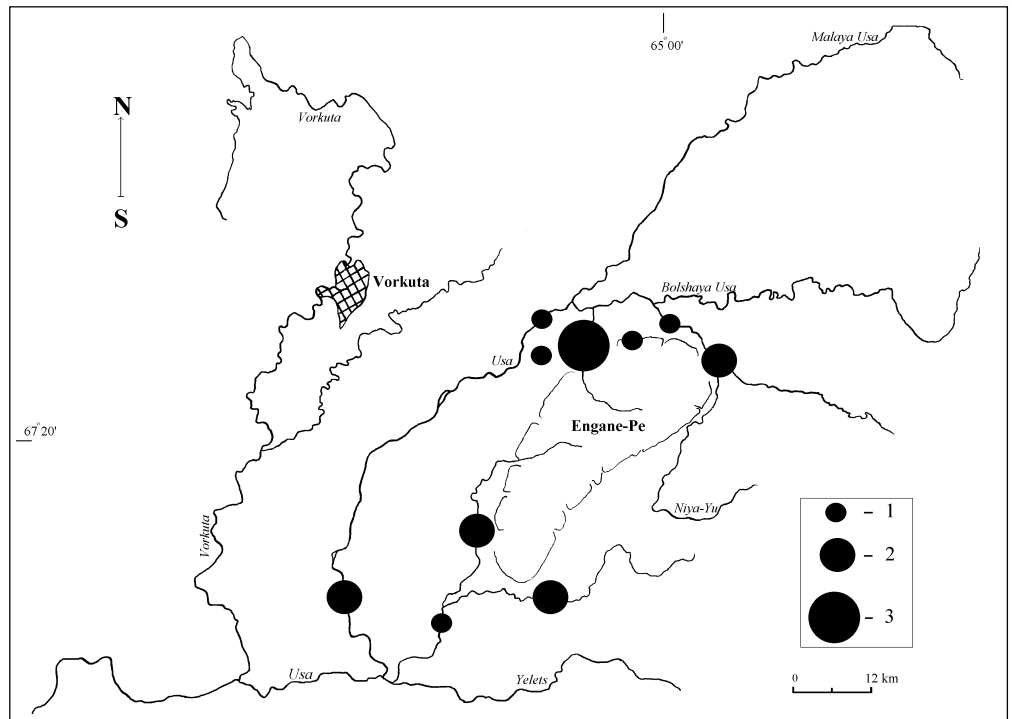

Figure 1. Distribution and numbers of Lesser White-fronted Geese in the Polar Urals in 1984–1987. Symbols: 1 = 1–5 adults; 2 = 6–10 adults; 3 = 11–40 adults.

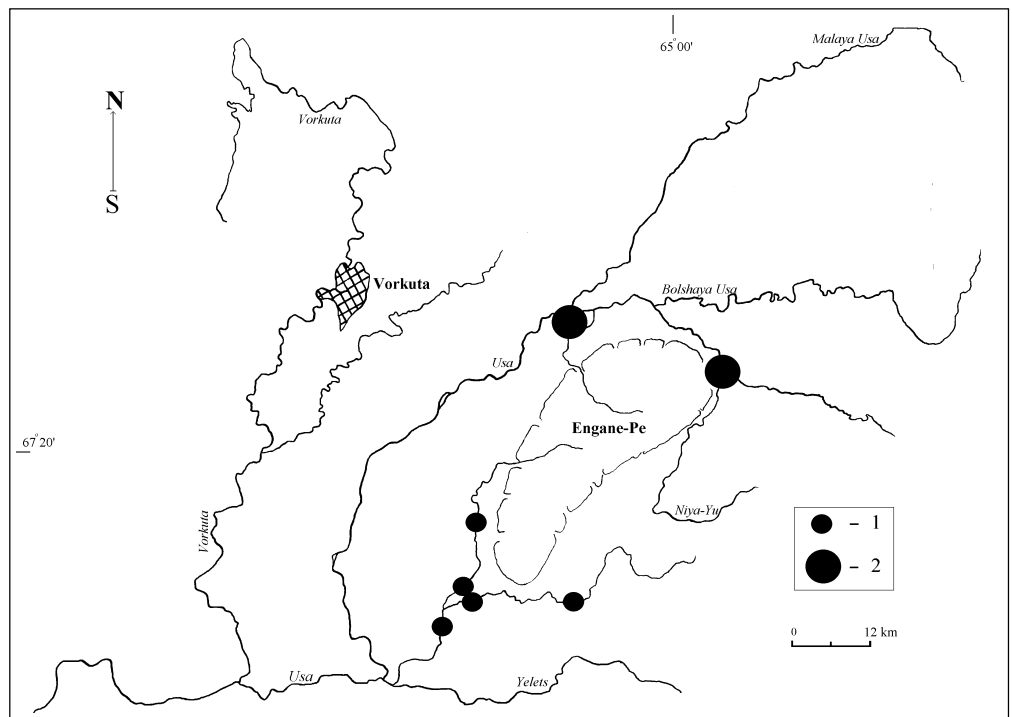

Figure 2. Distribution and numbers of Lesser White-fronted Geese in the Polar Urals in 1999. Symbols: 1 = 1–5 adults; 2 = 6–10 adults.

thickets and flood plain meadows in flat places. In the mountains Lesser White-fronts were confined to rocky canyons.

Breeding. LWfG did not breed in tundras of the Bolshaya Rogovaya River. The probable reason for that was unfavourable weather conditions in the beginning of the breeding season. The birds stayed within the area until the beginning of July and then left the area probably for moulting as did non-breeding LWfG in Yamal and the Polar Ural (Morozov & Kalyakin 1997). In the foothills and mountain areas of the Polar Ural LWfG bred successfully. However, all birds did not attempt to breed. Non-breeding birds left the area in summer and probably moved to unknown moulting areas. We found ten broods of LWfG in the Polar Ural study area. The number of goslings varied from 1 to 6, with an average of 3.5. The breeding success can be assessed as relatively good, yet unfavourable breeding

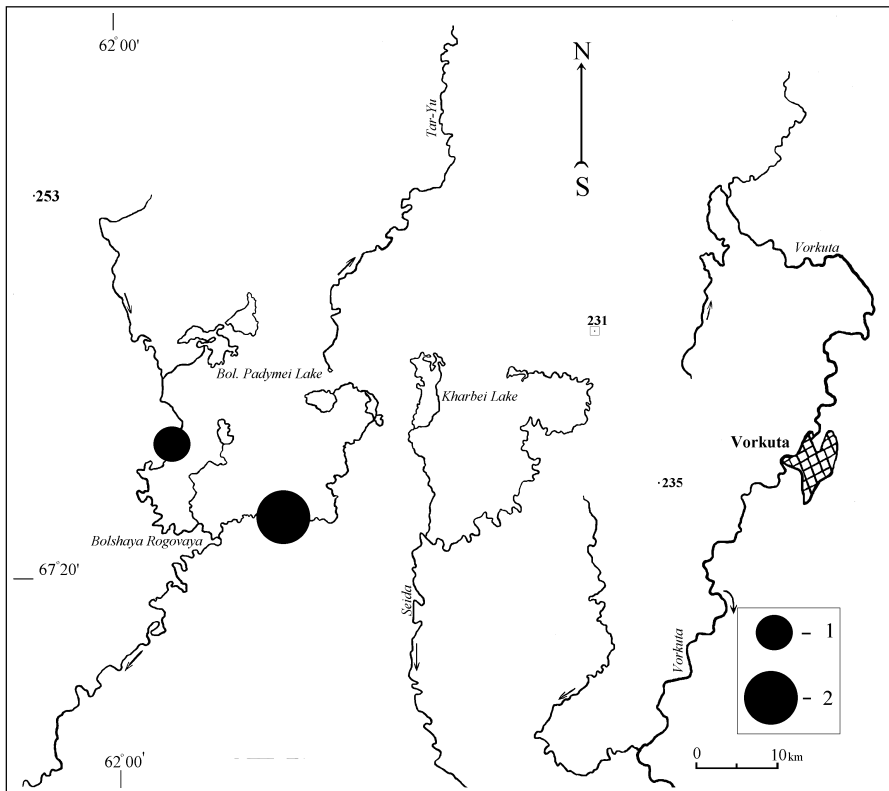

Figure 3. Distribution and numbers of Lesser White-fronted Geese in the Bolshaya Rogovaya River basin in 1999. Symbols 1 = 6–10 adults; 2 = 11–20 adults.

conditions could have affected it.

Ringling. Totally, seven LWfG (all goslings) were caught in 1999. Only one gosling was marked with standard metal ring. The other goslings were too small (weighting less than 400 g) for ringling.

6. Conclusions

The comparison of earlier data (Morozov 1988) with the data from this survey demonstrate that the population of LWfG in the eastern tundras of European Russia still preserves its viability. Still, the population is vulnerable because the distribution area has declined at least in the Polar Ural. Also the numbers of LWfG have slightly declined. This observed decrease may result from the unfavourable breeding conditions in 1999.

The present status of LWfG east of Bolshezemelskaya Tundra provides promising perspectives for a full-scale investigation and tagging effort of LWfG with colour rings and satellite transmitters, in order to reveal the migrating routes and wintering grounds. In turn, awareness of their migration routes and wintering grounds should lead to development of a complex of measures to conserve this globally threatened bird species.

7. Acknowledgements

This pilot project was financed by The Ministry of Agriculture, Nature Management and Fisheries of The Netherlands and by the Finnish LWfG EU Life project.

References

Aarvak, T., Øien, I. J., Syroechkovsky Jr., E. E., & Kostadinova, I. 1997: The Lesser White-fronted Goose Monitoring Programme. Annual report 1997. – Klæbu, Norwegian Ornithological Society. NOF Rapportserie. Report no. 5-1997.

Karvonen, R. & Markkola J. 1998: Satellite follow-up of the Yamal Lesser White-fronted Goose Sibyako (the Mother). In: Tolvanen, P., Ruokolainen, K., Markkola, J. & Karvonen, R. (eds.): Finnish Lesser White-fronted Goose conservation project. Annual report 1997. – WWF Finland Report 9:36–37.

Lorentsen, S.-H., Øien, I. J., & Aarvak, T. 1998: Migration of Fennoscandian Lesser White-fronted Goose *Anser erythropus*

mapped by satellite telemetry. – *Biological Conservation* 84:47–52.

Lorentsen, S.-H., Øien, I. J., Aarvak, T., Markkola, J., von Essen, L., Faragó, S., Morozov, V., Syroechkovski Jr., E. E. & Tolvanen, P. 1999: Lesser White-fronted Goose *Anser erythropus*. In: Madsen, J., Cracknell, J. & Fox, T. (eds): *Goose Populations of the Western Palearctic. A review of status and distribution.* – Wetlands International Publ. No. 48. Wageningen, The Netherlands. National Environmental Research Institute, Rønde, Denmark. Pp 144–161.

Madsen, J. 1996: Lesser White-fronted Goose. In: Heredia, B., Rose, L. & Paynter, M. (eds.). *Globally threatened bird in Europe. Action Plans.* – Strasbourg. France. Council of Europe Publishing.

Morozov, V. V. 1988: The Lesser White-fronted Goose in east of Bolshezemelskaya Tundra and Polar Urals. – *Resources of rare animals in RSFSR, their conservation and use.* Moscow. Pp. 71–77 (In Russian).

Morozov, V. V. 1995: Status, distribution and trends of the Lesser White-fronted Goose (*Anser erythropus*) population in Russia. – *Bulletin of geese study group of eastern Europe and northern Asia* 1: 131–144 (In Russian with English summary).

Morozov, V. V. & Kalyakin, V. N. 1997: Lesser White-fronted Goose (*Anser erythropus*) in Southern Yamal: retrospective analysis of population changes. – *Casarca* 3:175–191. (In Russian with English summary).

Rogacheva, E. V. 1992: *The Birds of Central Siberia.* – Husum Druck- und Verlagsgesellschaft. Husum, Germany.

Tucker, G. & Heath, M. 1994: *Birds in Europe: their conservation status.* – Cambridge, UK. BirdLife Conservation series No 3.

Vinogradov, V. G. 1990: *Anser erythropus in the USSR.* In: Matthews, G.V.T. (Ed.). *Managing waterfowl population.* – IWRB Spec. Publication 12:193–200.

Øien, I. J., Tolvanen, P., Aarvak, T., Litvin, K. E. & Markkola, J. 1999: Surveys and catching of Lesser White-fronted Geese in Taimyr Peninsula – preliminary results on autumn migration routes mapped by satellite telemetry. In: Tolvanen, P., Øien I.J. & Ruokolainen, K. (eds.): *Fennoscandian Lesser White-fronted Goose conservation project. Annual report 1998.* – WWF Finland Report 10 & Norwegian Ornithological Society, NOF Rapportserie Report no.1-1999:37–41.

New breeding and moulting areas of Lesser White-fronted Goose revealed in Indigirka, Yakutia

Evgeny E. Syroechkovski, Jr.

Russian Acad. Sci., Institute of Ecology and Evolution, Leninski prospect 33, Moscow, RUSSIA, e-mail: rgg@eesjr.msk.ru

1. Introduction

The status of the East-Asian population of Lesser White-Fronted Goose (*Anser erythropus*, later LWfG) is still poorly known. The current estimate of the total population is at least 14,000 individuals (Iwabuchi 1998), but only fragmented information about some few small breeding sites in Siberia has been presented in ornithological literature until recently (Kretchmar et al. 1991, Degtyarev & Perfiliev 1996).

In June–August 1999, the Goose and Swan Study Group of Eastern Europe and North Asia and IPEE, Russian Academy of Sciences arranged an expedition to Indigirka in Yakutia. The work was carried out as part of a project on surveying important goose areas in co-operation with the Japanese Association for Wild Geese Protection.

Several new breeding and moulting locations of LWfG were found in the middle and lower parts of the Indigirka river. The first information on breeding locations in Abyi Lowland is published by Artyukhov & Syroechkovski, Jr (1999). Here we present a more detailed review of the distribution of LWfG at Indigirka.

2. Results

2.1. Breeding distribution

Breeding LWfG were found in the taiga areas of Abyi Lowland. The main part of the observations was made by A.I. Artyukhov along the tributaries of Indigirka River north of the Momi Ridge (67°32'N; 144°15'E). In 9 out of 15 study areas in the taiga zone visited by our expedition in summer 1999, no LWfG was found.

About 250 birds (including 24 broods) were observed along the Indigirka River south of the Momi Ridge. According to interview data and previously published material, at least six more areas possessed breeding LWfG (see Figure 1). All observations of LWfG were reported from the marginal parts of the Abyi Lowland not further than 50 km from the mountains. The preferred habitat of LWfG was slow-flowing river stretches not wider than 100 m, with numerous branches and islands. No birds were seen on the Indigirka river and closer than 5 km from the main river, most likely due to disturbance and illegal hunting.

The first brood, with 3–5 days old goslings, was recorded on 27 June. The average brood size was difficult to estimate. We have the following data on brood size: 2 broods with 5 young; 6 broods with 4 young, and 2 broods with 3 young. On 15 July a flock of ca. 20 adults and 60 young was seen. In some broods it was not possible to estimate accurately the number of goslings. If we calculate the approximate average brood size during the first 3 weeks of age of the goslings up to mid July, we obtain an average of about 4 goslings per pair for single broods, 6 goslings per pair in an aggregation seen on 15 July, and an average of 5 goslings for all observed broods (n = 20). Survival in brood aggregations could possibly be higher than for single broods, but the sample size is too small to estimate this with certainty.

At the middle stretches of the Uyandina River (68°30'N; 142°30'E), 39 LWfG were registered during 5 days in late June and one pair was probably breeding (Table 1). Also the Uyandina river consists of numerous branches and green flood plain pastures where most of the LWfG were seen. Again, all geese were mostly met at shallow remote parts of the river that are rarely visited by native people in summer.

2.2. Distribution of moulting non-breeders

Northward moult migration of the non-breeding LWfG is earlier described from Taimyr (Syroechkovski, Jr. 1996).

During our work in 1999 this phenomenon was also observed for the East Asian population. Lesser White-fronts do not moult in the Indigirka Delta but can be met in the small river valleys west and east of the delta. The main location of moulting non-breeding LWfG was found in the basin of the rivers Melkaya and Volchya (about 72°N, 147°E).

Hunters from Russkoe Ust'e settlement reported that about 10–15 years ago a concentration of about 2,500 LWfG was found in the lower Volchya River. The place have the name "Piskun" (local name for LWfG) and was regularly visited by hunters who killed 50–300 LWfG every July in the 1980's–early 1990's.

During 1990's the remaining LWfG have moved to smaller rivers nearby due to increasing disturbance and hunting pressure. In early July 1999, several hundreds were observed in the area and on 23–25

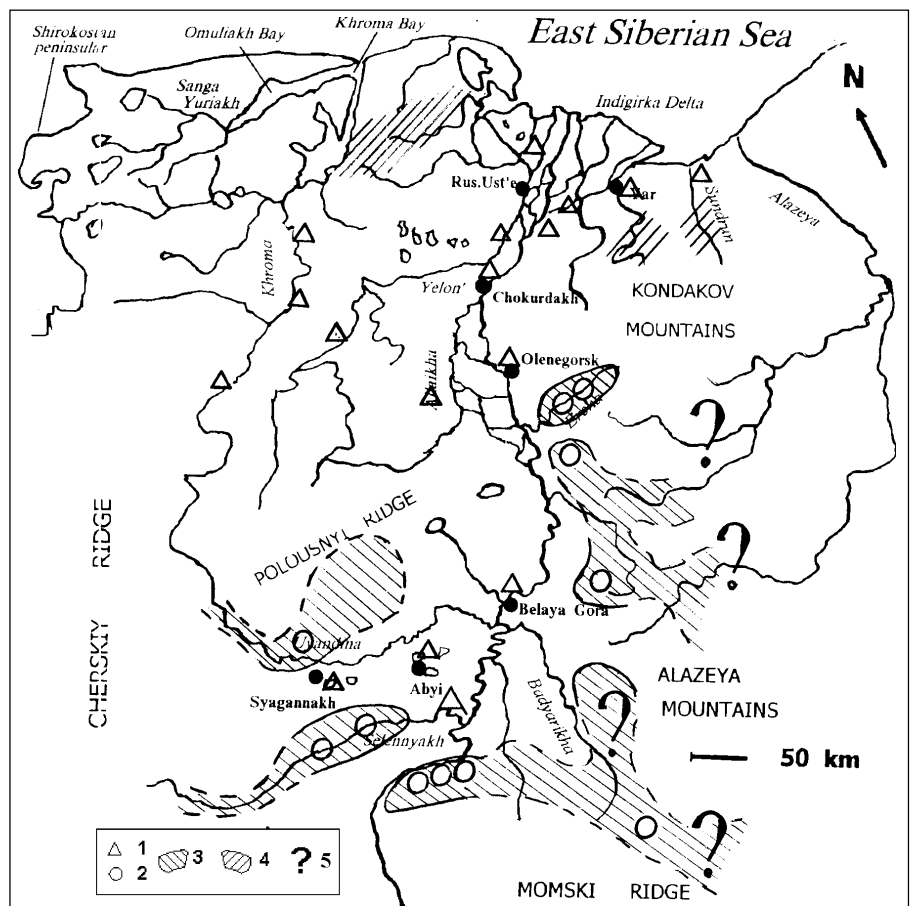

Figure 1. Distribution of LWfG at Indigirka. Legend symbols: 1 – non-breeding records; 2 – proved or assumed breeding records; 3 – assumed breeding range; 4 – current distribution of moulting non-breeders 5 - areas with suitable breeding habitats for the species

Table 1. Numbers of geese in the middle stretches Uyandina River in June 1999 (* = individuals assumed to be breeding).

	Buor-Yuryakh	Uyandina Upstream	Uyandina downstream	Mountain field-camp	Total.
Boat trip, km	480	270	270	–	
Observation period	19–20 June	21–22 June	25–26 June	23–24 June	19–26 June
Anser fabalis	*3	*28	*24	2	57
Anser albifrons	1	*60	*32	8	101
Anser erythropus	-	15	14	*10	39
Unidentified geese	3	11	45	8	67
Total	7	124	116	28	275

July, we were able to find only 24 birds on the Melkaya River in areas reachable by motor boat and by foot. We suggest that moulting concentrations of LWfG still exist in the area, but are relocated and dispersed due to human disturbance. Interview data indicate the presence of several moulting locations of LWfG in the 1960's-1980's also upstream Gusinaya River, and small tributaries at Khromskaya Bay west of the Indigirka Delta and in the middle stretches of Sundrun and Shandrin rivers east of Indigirka River.

2.3 Status of the LWfG populations at Indigirka

By summing up our field observations and interview data it is possible to specify the following breeding areas of LWfG in middle Indigirka (Figure 1.):

1. Branches and tributaries of Indigirka, mainly on the east coast, south of Momski Ridge and nearly up to Krest-Major. This is about 100 km along the river valley, including the tributaries Burunnas and Kyllakh
2. About 200 km of a valley of middle reaches of Uyandina River (approximately 50 km from west to east) just east from the mountains Esteriktyakh-Tas
3. Khatnyngnakh river basin (tributary of Uyandina River), except its lower reaches
4. Valley Sellenyakh River for about 100-150 km of the valley just east of the mountains
5. the upper and middle stretches of the rivers flowing north from the Momski Ridge – Bour-Yuryakh, Myatis, and almost the whole basin of the rivers Chukcha, Sakanya, Behelekh
6. Upstream of Badyarikha River and its tributary Kamchatka. Few other small rivers coming down from Alazeya Plateau, and also upstreams Ozhogina River which belongs to Kolyma Basin (Labutin, Perfiliev, 1991)
7. the middle stretches of Bolshaya Ercha River between Kondakovskoe Plateau and Ulakhan-Sys Ridge
8. Several sites in Shangina River Basin

Moulting non-breeders were concentrated in the tundra areas between Khroma Bay and Indigirka Delta (9). Some few locations still exist on the rivers Volchya and Melkaya and likely on other small rivers of the area out of reach by motor boats. The current breeding range of LWfG includes the periphery of Abyi Lowland, and does not include the mountain areas with the poorly developed valleys and the central plains of Abyi Lowland (Figure 1). The almost continuous strip of the LWfG's breeding range is 10-50 km wide. The interview data verify that LWfG do not breed, and occur only sporadically in more northern and more southern areas (Allaikhovski and Momski regions of Yakutia). Another promising area to search for LWfG breeding grounds is the western part of the Kolyma Lowland, upstream Alazeya River (about 67°30'N; 151°E).

According to our estimation, a total of roughly 3,500–4,500 LWfG could be found during summer in the Abyi Lowland and at least an additional 500 birds as non-breeders in the tundra areas. The estimation of 3,500–4,500 individuals was made by extrapolating the actual field data (ca. 250 individuals observed) for the total area of suitable LWfG habitats in the whole Abyi Lowland (covering of an area of ca. 300 x 500 km, of which a minor fraction was surveyed). This estimated number is approximately 20–25 % of the total East Asian LWfG population, and allows us to consider the middle stretches of Indigirka as one of most important areas for conservation of breeding LWfG.

3. Protection status and threats

None of the areas important for LWfG in Indigirka Valley have any protection status, even though some of them now experience a year-round hunting pressure and an increasing human disturbance. The main breeding area discovered by us is located only 50 km downstream Indigirka River from a large coal deposit planned to be developed in the near future. The local people have very poor experience in identification of LWfG and are unaware of the importance of the protection of this species.

We recommend the following measures on LWfG protection at Indigirka:

- creation of a network of local protected areas, and in the future, a Nature Reserve (Zapovednik), to protect the high level of biodiversity in the region considering the absence of Nature Reserves in similar northern taiga lowlands of Yakutia
- implementation of the public awareness campaign and environmental educational programmes among the local authorities and people
- regulations on the timing of spring hunting in taiga areas in order to make a shift in the hunting pressure to ducks and reduce the hunting pressure on geese.

4. Acknowledgements

We sincerely thank our colleagues A. Artyukhov, E. Lappo, S. Rupasov, C. Zoeckler, J. Lugert, K. Shenk and others for their assistance during the field work. The local people and administration as well as representatives of the Ministry of Nature Protection of Yakutia were most helpful during our expedition. The funding of the project was possible due to the grant of Japanese Fund for Global Environment (JFGE), Arctic Ecology and Anthropology Research Centre (Moscow) and several other small sources. Comments of E. Lappo and K. Litvin were helpful during the preparation of the manuscript.

References

- Artyukhov, A. I. & Syroechkovski, Jr, E. E. 1999: New data on distribution of Lesser White-fronted Goose in the Abyi Lowland (Eastern Yakutia) – Casarca 5: 136-143
- Degtyarev A. G. & Perfiliev V. I. 1996: Lesser White-fronted Goose (*Anser erythropus*) in Yakutia. – Casarca 2: 113-124
- Iwabuchi, S., Ikeuchi T., Gang L., Yung, J. & Yue S. P. 1998: Record count of Lesser White-fronted Geese at Dongting Lake, China. Threatened Waterfowl Specialist Group News No. 11:38–40
- Kretchmar A. V., Andreev A. V. & Kondratiev A. Ya. 1991: Birds of northern plains, Leningrad, Nauka: 1-288.
- Labutin Yu. V. & Perfiliev V. I. 1991: Structure and spatial distribution of bird population of Ozhoginski Dol. – Fauna and ecology of animals of Yakutia. Yakutsk, Yakutian State University publ. house: 87-97.
- Mikhel N. M. 1935: Materials on bird fauna of Indigirski Region – Arctic Institute Publ, Ö. XXXI (biology), Leningrad: 1-101.
- Syroechkovski, Jr, E. E. 1996: Present status of the Lesser White-fronted Goose (*Anser erythropus*) populations in Taimyr and some peculiarities of the system of species migrations in the Western Palearctic. – Casarca 2: 71-112

The status of Lesser White-fronted Goose in the Kola Peninsula, north-western Russia

Esko Aikio¹, Sami Timonen², Natalia Ripatti³ & Erkki Kellomäki³

¹ A 777, Korrettoja, 99800 Ivalo, FINLAND, e-mail: esko.aikio@samediggi.inet.fi

² Kosteperäankatu 2 B 12 K, 90100 Oulu, FINLAND, e-mail: sami.timonen@vyh.fi

³ Regional Environmental Agency of Häme, P.O. Box 131, FIN-13010 Hämeenlinna, FINLAND, e-mails: natalia.ripatti@vyh.fi, erkki.kellomaki@vyh.fi

1. Introduction

The recent status of the Lesser White-fronted Goose (*Anser erythropus*, later LWfG) in the Kola Peninsula in north-western Russia is unclear. According to the scientific literature published in 1990's there is only scattered data about the breeding and migration of LWfG in the Kola Peninsula.

In this article we try to summarise the available knowledge about LWfG in this region, especially during the breeding season, and try to estimate the status of it. The summary is not a complete one, and it is based on the material published in some Russian journals, hand books and questionnaires to Russian scientists (V. Zimin, K. Litvin, A. Giljazov, V. Bianki).

Very little information exists about the breeding population of LWfG in the Kola Peninsula. In the beginning of the 20th century, LWfG was said to be regular during migration in the region of Aynovy Islands (Heinäsaaret) (Figure 1). In the pictorial bird book of Heinäsaaret made by the Finnish ornithologist Einari Merikallio (1939), there is a note (in Finnish): "the goose species is hard to determine because of the shyness of the birds, but it seems that LWfG is the commonest one visiting Heinäsaaret, it might also have bred here (according to a monk, whose information I could not confirm). LWfG are seen mostly in pairs or most usually in small flocks (less than ten birds) at least in the early summer, but also in August 1928. In midsummer I have not observed them. The harvest time may frighten them away. The hay makers have told that the geese have sometimes wandered all around in the hayfields which indicates that some goose species have at that time spent their time here in big numbers".

The breeding of several pairs of LWfG has been confirmed in the larger island of Heinäsaaret at least in 1949 (Dementiev & Gladkov 1967). In addition, according to Tugarinov (1941), "...the northern limit of breeding distribution of LWfG in the Kola Peninsula has reached seaside only rarely, while it is a very common bird on inland peninsula, also on the mountainous lakes".

In the White Sea region, in northern Russian Karelia, the southern limit of the breeding distribution of LWfG has reached the Nuorunen hill in Paanajärvi National Park in Kuusamo district, c. 60° N. On 24 July, 1937, a female LWfG with four goslings has been caught on a lake in mountainous tundra zone of the Nuorunen hill (Suomalainen 1952). According to an assumption by Dr. V. Zimin, LWfG probably was a breeding species even in Karelia at the beginning of the last century. At present, this area is included in the territory of Paanajärvi National Park. In this area there has been carried out research of the bird fauna from the end of the 1980's to the beginning of the 1990's by Dr. Sergey Sazonov from the Karelian Research Centre RAS, but LWfG have not been observed. Later on, Dr. Vladimir Zimin and two Finnish ornithologists, Mr. Esa Lammi and Mr. Ilkka Heiskanen have visited the Nuorunen hill in July, 1998. During their visit no LWfG or any faeces of the species were observed (Zimin 1998).

Since the 1930's, a systematic scientific research of flora and fauna has been carried out in the Laplandsky Strict Nature Reserve (Zapovednik) (Figure 1) in the westernmost part of the Kola Peninsula, but breeding pairs or goslings of LWfG have not been observed in this area in the years 1930–1998 (A. Giljazov, pers. comm). There has been only some observations of LWfG: 25 May, 1937, one pair was seen at Tsuna River, and in autumn 1939 one juvenile was found at the Lake Ekostrovskaya Imandra (possibly on

migration) (Figure 1). Later on, there has been only two observations of LWfG in the Laplandsky Strict Nature Reserve in the breeding period: on 27 June, 1969 three geese in a bog area in Lake Rumel and a pair flying at Lake Tsuno on 25 May, 1982 (Semenov-Tjansanski & Giljazov 1991).

Many observations of LWfG have been made in the highland between the Rivers Teriberka and Mutska (Figure 1) (Kitshinski 1960). Mikhailov (1992) considers LWfG to be a rare species in this area. According to the latest publications (Bianki et al. 1993), LWfG is regarded as a rare breeding species on the islands and in the coastal zone of the Barents Sea in the western and northern parts of the Kola Peninsula. In this area LWfG is estimated as a scarce breeder with a frequency of breeding only 1–3 times in 10 years.

In the region of the Pasvik Nature Reserve in the Paz River (Paatsjoki) valley, during the field work of Dr. Bianki from 1991 to 1996, LWfG was not observed (Bianki 1997). For the first time, in 1996, in the region of Yaniskoski (Jäniskoski), a Russian ornithologist Dr. Bakkal (Institute of Zoology, RAS, St. Petersburg) investigated the territory on the eastern side of Paz River, south of the Pasvik Nature Reserve. According to the results of this survey, LWfG was very rare in this area or was missing totally.

The main breeding area of LWfG in the Kola Peninsula is said to be in the inland mountain areas of the north-eastern parts of the peninsula. Bianki et al. (1993) mention that LWfG breeds most frequently in the area between the Yokanga and Ponoy rivers (Figure 1). Here, as in the Kanin Peninsula, the breeding frequency has been estimated at 8–10 times in 10 years, but the breeding density is estimated similar to the western and northern parts of the Kola Peninsula (Bianki et al. 1993). Bianki et al. (1993) also present data from four nests measured by the Tundra Station, but the exact locations of the nests are not mentioned. LWfG is commonly seen in the area during spring and autumn migration, but no moult migration has been observed (Bianki et al. 1993).

2. What is the present distribution of LWfG in the Kola Peninsula?

In the years 1976–1981, the breeding bird fauna of the north-eastern Kola Peninsula was extensively surveyed, and at least one flying LWfG was seen in the Yokanga River. On the other hand, in the same article there is a note that LWfG breeds regularly in the areas near River Yokanga and Lake Enozero (Mikhailov 1993). In the same area, Mr. Ilppo Kangas from Finland found two LWfG flocks consisted of 18 and 22 individuals (part of them probably juveniles) in early September, 1997 (I. Kangas, pers. comm.). In addition, in September 1999, I. Kangas (pers. comm.) observed a flock of 17 ind. and a brood of two adults and two juveniles in an area near Lake Maksim (c. 80 km NNW of Lake Enozero). In the summer 1999, another brood of 5 birds (probably 2 ad and 3 juv) was reported by another Finnish observer in the pine forest zone in the north-eastern parts of the Kola Peninsula (I. Kangas, pers. comm), but the observer of the latter brood (E. Petterson) unfortunately died before he reported the details of his observation.

One breeding LWfG pair was found in 1978 or in 1979 near the mouth of the river Ponoy in a small river valley during extensive surveys carried out within an area of c. 800 km² (Filchagov & Tserenkov 1984). On 31 August, 1992 one LWfG was seen together



Figure 1. Map of the Kola Peninsula. 1 = Teriberka, 2 = Mustka, 3 = Aynovy Islands (Heinäsaaret), 4 = Ekostrovskaja Imandra and 5 = Laplandsky Strict Nature Reserve (Zapovednik).

with Bean Geese in the Chunozero Lake valley (A. Giljazov, pers. comm.).

According to Bianki et al. (1993), LWfG occur during the spring migration along the coastline of the Kola Peninsula, excluding the coastal area south of mouth of the river Ponoy. On the Rybachiy Peninsula (Kalastajasaarento) (Figure 1), LWfG is said to be more numerous than elsewhere in the Kola Peninsula. During the autumn migration the geese are seen in the same areas, more regularly in the area north-west from Yokanga River. According to Bianki et al. (1993), moulting LWfG has been observed only on Kalastajasaarento (6–10 ind./km²), but there are no notes about the regularity of the migration.

3. Discussion

The present status of LWfG on the Kola Peninsula is unclear, especially in the north-eastern and middle parts of the peninsula. People visit this most potential breeding area only very rarely, and thus these remote areas have been undisturbed for a long time (V. Zimin, pers. comm.).

It is clear that more detailed research is needed in this area to reveal the current status of LWfG. It would be important to localise the present breeding and moulting sites of the LWfG population in Kola, which perhaps represents the majority of the genetically and conservationally discrete unit of the Fennoscandian population assumed by geneticists (Ruokonen & Lumme 1999). Surveys would be important also for the knowledge of the local bird fauna and the status of natural habitats in this area. For the field work, helicopter and boat transport is necessary because there are no roads in the area (A. Giljazov, V. Bianki, V. Zimin, pers. comm.).

The human influence is increasing in the north-eastern Kola Peninsula, mainly because of fishing and hunting tourism and mining industry. It is notable and regrettable, that sports hunters from western countries arrange goose hunting trips to the Kola Peninsula at spring time.

4. Acknowledgements

Some data of LWfG in the Kola Peninsula has been received by the conservation co-operation between Finland and Russia within the framework of the Finnish LWfG Life Project. Thanks to Dr. V. Bianki (State Nature Reserve of Kandalaksha), Dr. V. Zimin (Institute of

Zoology, Karelian Research Centre RAS), Dr. A. Giljazov (Laplandsky Biosphere Reserve) and Dr. K. Litvin (Bird Ringing Centre, Russian Academy of Sciences) for giving data of the status of LWfG.

References

- Bianki V. V., Kohanov V. D., Koriakin A. S., Krasnov J. V., Paneva T. D., Tatarinkova I. P., Chemiakin R. G., Shklarevich F. N. & Shutova E. V. 1993:** Ptitsi Kolsko-Belomorskogo Regiona. – *Rus. ornitol. zhurn.* 2(4):491–586. (In Russian)
- Dementiev, G. P. & Gladkov, N. A. (eds.) 1967:** Birds of the Soviet Union. – Vol.7. pp. 342–346.
- Filchagov, A. V. & Tserenkov, A. E. 1984:** Tsislennost vodoplavaytshih ptits na vostotsnom poberezhe Kolskogo polyostrova. – *Ornitologija. M.: MGY, Vyp. 19.* pp. 215–216. (In Russian)
- Kitshinski, A. A. 1960:** Faune i ekologi ptits Teriberskogo rajona Murmanskoi oblast, Tr. Kandalakshkogo gos. zapovednikah. – Murmansk: Kn. izd-vo. Vip. 2. pp. 122–212. (In Russian)
- Merikallio, E. 1936:** Heinäsaarten lintukuvakirja. 198 pp. Helsinki, Otava, 1939. (In Finnish)
- Mikhailov, K. E. 1993:** Avifauna zonalnyh tundr severnoi tsasti Kolskogo polyostrogo. – *Rus. ornitol. zhurn.* 2, 1:7–28. (In Russian)
- Ruokonen, M. & Lumme, J. 1999:** Phylogeography and population genetic structure of the Lesser White-fronted Goose. In: Tolvanen, P., Øien I. J. & Ruokolainen, K. (eds.): Fennoscandian Lesser White-fronted Goose conservation project. Annual report 1998. – WWF Finland Report 10 & Norwegian Ornithological Society, NOF Rapportserie Report no. 1-1999:51–52.
- Semenov-Tjan-Shanski, O. I. & Giljazov, A. S. 1991:** Ptitsi Laplandii. (In Russian)
- Suomalainen, P. 1952:** Havaintoja Oulangan-Paanajärven seudun ja kaakkois-Sallan linnustosta – *Ornis Fennica* 29(3):88–102. (In Finnish)
- Tugarinov, A. J. 1941:** Fauna of the USSR, Ptizi, T1, v.4, M-L.
- Zimin, V. B., Artemiev, A. V. & Lapshin, N. V. 1998:** Raport “Vesennie skopleniya migriruyushih ptis na Olonetskoi ravnine v 1998”. (In Russian)



Photo. A flock of White-fronted Geese (with four Red-breasted Geese and one Lesser White-fronted Goose visible in this photo) taking off from Lake Korzhynkol, Kazakstan © Petteri Tolvanen, October 1999

Monitoring the autumn staging of Lesser White-fronted Geese in Kazakstan, October 1999

Petteri Tolvanen¹, Toni Eskelin¹, Tomas Aarvak², Götz Eichhorn³, Ingar Jostein Øien² & Elena Gurtovaya⁴

¹ WWF Finland, Lintulahdenkatu 10, FIN-00500 Helsinki, FINLAND, e-mails: tolvanen@sll.fi, teskelin@paju oulu.fi

² Norwegian Ornithological Society (NOF), Seminarplassen 5, N-7540 Klæbu, NORWAY, e-mails: tomas@birdlife.no, ingar@birdlife.no

³ Zoological Institute, University of Frankfurt; F.W.v. Steuben- Str. 90/ F28, D-60488 Frankfurt am Main, GERMANY, e-mail: geichhor@stud.uni-frankfurt.de

⁴ Russian Academy of Sciences – Bird Ringing Centre, Leninski Pr. 86-310, Moscow 117313, RUSSIA, e-mail: klitvin@gol.ru

1. Introduction

In October 1999, two parallel surveys of Lesser White-fronted Geese (*Anser erythropus*, later LWfG) were carried out in northern Kazakstan. One group surveyed the Kustanay region, which is already well known as a very important staging area for the western LWfG populations breeding in the area from the Taimyr Peninsula to Fennoscandia (Tolvanen & Pynnönen 1998, Markkola et al. 1998, Tolvanen et al. 1999b, Lorentsen et al. 1999) Another group studied the Kurgaldzhino–Tengiz area in north-central Kazakstan, c. 300 km ESE of the Kustanay region. This area is known as an important staging area for arctic geese (Vinogradov 1990), and two out of three of the LWfG tagged with satellite transmitters on the Taimyr Peninsula had a stopover in the area during autumn migration in 1998 (Øien et al. 1999).

The aims of the surveys was to: 1) monitor staging numbers of LWfG and other goose species; 2) study the breeding success; 3) identify threats to LWfG and clear out possibilities for conservation of the species in these areas and 4) discuss continuation of the conservation work with local conservation organisations and nature management authorities. In the poorly known Kurgaldzhino–Tengiz area, a basic objective was also to locate the most important staging areas for LWfG. Through these two parallel surveys, contemporary and comparable data on the occurrence of LWfG in these areas was

collected in order to reveal the relative importance of the two areas as staging grounds for LWfG. For results from earlier expeditions to the Kustanay region, see Tolvanen & Pynnönen (1998), Markkola et al. (1998) and Tolvanen et al. (1999b). Results from the 1999 surveys published by Gurtovaya et al. (1999) were preliminary, so the present paper is the recommended source of reference for the figures.

2. Methods

The field surveys were carried out in the period 1–13 October, 1999 in the Kustanay area, and 2–13 October in the Kurgaldzhino–Tengiz area. The schedule of the survey and a list of surveyed roosting lakes with co-ordinates is shown in Table 1. To achieve comparable results with the 1996 and 1998 surveys in the Kustanay region, and to avoid double counting of the geese, we surveyed as many as possible of the previously visited lakes, starting from the SW parts of the region and proceeding towards N. By the help of local expertise we found that some of the lakes studied in the Kustanay region in 1998 (e.g. Lake Biesoygan) had dried out, so the itinerary had to be modified. The weather was sunny and exceptionally warm throughout the survey period in both areas, with day maximum temperatures up to 25°C and only some few frosty nights.

Our methods for counting geese and estimating species and age ratios followed the 'Field instructions for monitoring LWfG'

Table 1. The surveyed lakes and the time schedule.

Name of the lake	Date of survey	Co-ordinates	
<i>Kustanay region</i>			
Lake Kulykol	2–3 October	51° 20'N	61° 50'E
Lake Ayke	4–5 October	51° 05'N	61° 34'E
Lake Batpakkol	6 October	51° 25'N	62° 39'E
Lake Kulakol	7 October	51° 13'N	64° 33'E
Lake Kushmurun	8–9 October	52° 36'N	64° 28'E
Lake Koybagar	10 October	52° 35'N	65° 32'E
Lake Tyuntyugur	11 October	52° 43'N	65° 53'E
Lake Bozshakol	12 October	53° 08'N	65° 57'E
Lake Sarykol	12 October	53° 20'N	65° 32'E
Lake Tali	12–13 October	53° 16'N	64° 59'E
<i>Kurgaldzhino–Tengiz region</i>			
Lake Sholak	2 and 13 October	50° 34'N	69° 46'E
Lakes Zhylandyshalkar, Uyalyshalkar and Zhanybekshalkar	3 October	50° 38'N	70° 27'E
Lakes Kumdykol and Ashi-Kumkol	4 October	50° 33'N	70° 46'E
Lake Kubikol	6 October	50° 53'N	68° 42'E
Lake Sochinskoye	7 October	50° 58'N	68° 12'E
Baumanskoye, Lake Korzhynkol	8 October	51° 05'N	68° 55'E
Karazhar, Lake Zultankeldi	9 October	50° 29'N	69° 33'E
Lake Saumalkol	9 October	50° 40'N	69° 43'E
Lake Shandykol	10 October	51° 04'N	69° 41'E
Lake Shunkyrkol	10 October	51° 10'N	69° 57'E
Lake Alakol	11 October	51° 15'N	69° 44'E
Burevestnik, Lake Zharlykol	11 October	51° 02'N	69° 52'E
Lake Kumkol	12 October	50° 46'N	70° 02'E
Lake Zhumai	12 October	50° 42'N	69° 48'E



Photo. Local hunting inspector of a private company holding a hunting bag of White-fronted Geese and a Ruddy Shelduck at Lake Shandykol, Kazakhstan. © Petteri Tolvanen, October 1999

(Tolvanen et al. 1999c). The numbers of geese on the roosting lakes were counted early in the morning during the mass departure from the roosting lake to the feeding grounds. The sites of the morning counts were selected to ensure that all flight departure sectors were covered. Data on species and age ratios were collected during daytime in random samples of the flocks returning back from the feeding places to the roost. To avoid possible bias caused by different diurnal activity of different species, samples were taken evenly during the whole return flight period. At Lake Kulykol (in the Kustanay region) samples were taken in different places in two consecutive days, but at all other lakes all samples at a site were collected during one single day.

For the lakes where adequate sample data were not obtained, a weighted mean of the species proportion of the sampled lakes was used to estimate the species ratio of the lakes where we don't have sufficient data. The weighting was made by summing up the estimates of the number of individuals (of that particular species) from the sampled lakes, and dividing it by the total number of geese at these lakes. The 95% confidence intervals for the species proportions in the sample data (Bernoulli distributed) were calculated using the following formulas:

$$\text{Lower 95\% confidence limit} = s - 1.96 \times \sqrt{s \times (1-s)/n}$$

$$\text{Upper 95\% confidence limit} = s + 1.96 \times \sqrt{s \times (1-s)/n},$$

where s = mean proportion of the species in the sample data set, n = sample size (at that particular lake) and $\sqrt{\quad}$ = square root.

3. Results

3.1. Kustanay region

The total number of geese observed was c. 247,000 individuals (Table 2). The largest concentrations of geese were counted at the lakes Kulykol and Ayke, while the lakes Koybagar, Batpakkol and Tyuntyugur had moderate numbers. At the other lakes only low numbers of geese were seen. At Lake Kulykol, it was somewhat problematic to find a suitable point for the morning counts: the geese had several flight directions from the roost, and because of huge numbers of birds and intense morning departure, some flocks could have been missed.

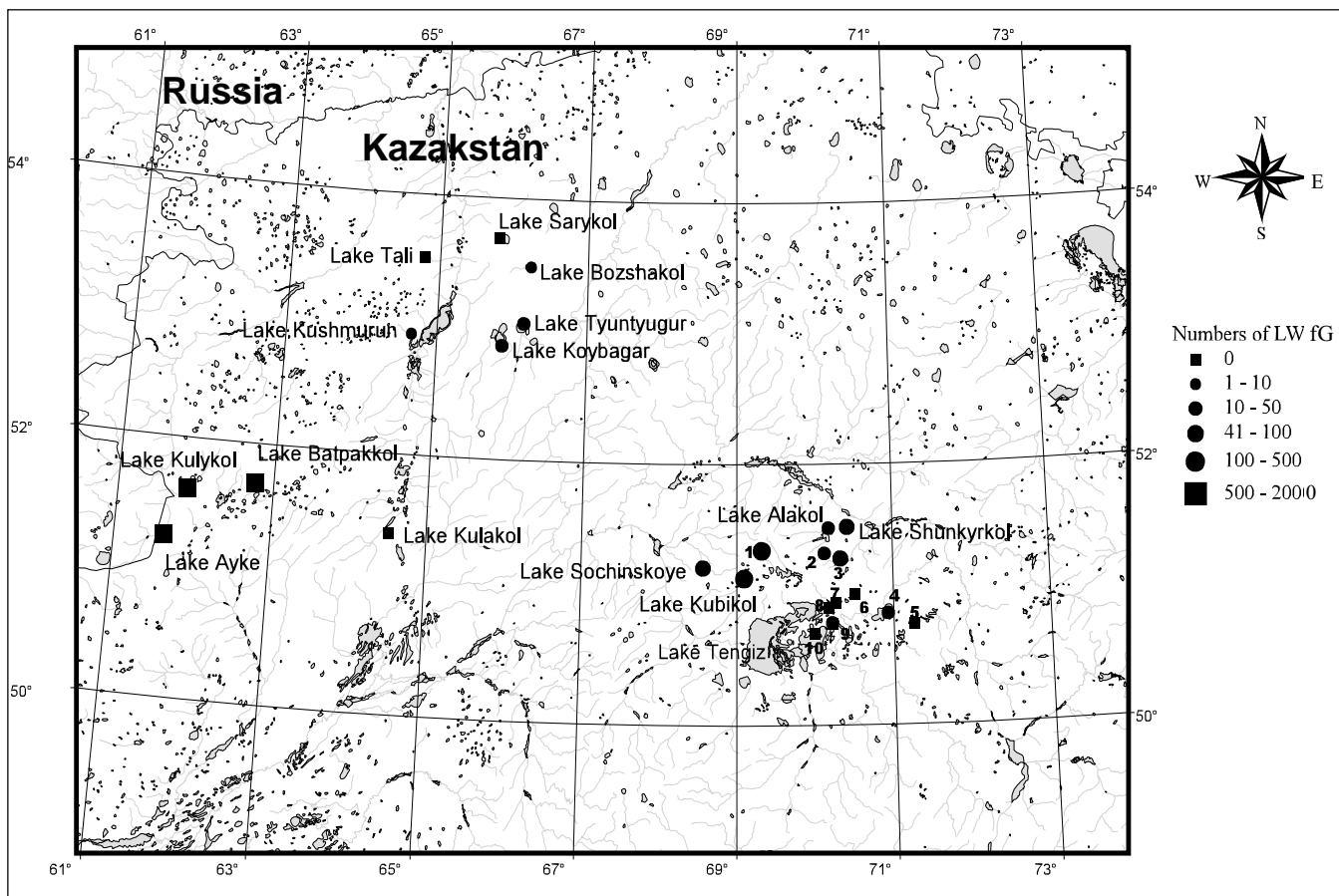

Figure 1. Map of the surveyed area: (1) Baumanskoye, Lake Korzhynkol, (2) Lake Shandykol, (3) Burevestnik, Lake Zharlykol, (4) Lake Zhylandyshalkar, (5) Lake Kumdykol, (6) Lake Kumkol, (7) Lake Zhumai, (8) Lake Saumakol, (9) Lake Sholak and (10) Karazhar, Lake Zultankeldi.

Hence, the total number of geese at Lake Kulykol represents a minimum value, while for the other lakes the total numbers should be regarded as reliable absolute figures.

Adequate sample data sets for species ratio was obtained at four lakes (Kulykol, Ayke, Koybagar, Tyuntyugur), hosting altogether 204,000 individuals, i.e. 83 % of the total number (Table 2). In total, 20,400 individuals (680 samples of 30 ind., i.e. 10 % of the total number of geese) were included in the species ratio samples at these lakes. At these well sampled lakes, 1.54 % of the geese were LWfG, 70.1 % White-fronted Geese (*Anser albifrons*), 9.6 % Greylag Geese (*A. anser*) and 19.6 % Red-breasted Geese (*Branta ruficollis*) (Table 2). The respective estimates for numbers of individuals at these four well sampled lakes were c. 3,140 LWfG (95 % confidence intervals for the estimate 2,580–3,720 individuals) and c. 40,100 Red-breasted Geese (95 % confidence intervals 37,900–42,300 ind.) (Table 2).

Except for the lakes Kulykol, Ayke, Koybagar, Tyuntyugur, adequate sample data was not obtained, and a weighted mean of the species proportion was used for these places. A distinct difference between the S/SW and N/NE parts of the region in the species proportion was found, based on the sample data sets (Table 2), and this also fits with our subjective impression in the field. Thus, the weighted means were calculated separately for the S and N parts of the area (see Table 2). For Lake Batpakkol, where the absolute number of Red-breasted Geese could be directly counted, the estimates for the *Anser* species was calculated as a weighted mean of the proportions of *Anser* geese at the lakes Kulykol and Ayke (see Table 2). At the lakes Kulakol and Tali, the numbers of each species were counted directly without sampling. The total estimate for LWfG in the survey, including the non-sampled lakes, was c. 3,880 individuals, and for Red-breasted goose c. 44,300 individuals (Table 2).

In addition to the species mentioned in Table 2, one Brent Goose of the nominate race (*B. b. bernicla*) was seen at Lake Kulykol on 1

October. No Bean Geese (*A. fabalis*) were recorded in this area.

The age ratio of LWfG was 56.1 % adults and 43.9 % juveniles ($n = 212$ ind., 95 % confidence intervals for $juv\% = 37.22\text{--}50.58$), and the corresponding age ratio in White-fronted Goose ($n = 450$ ind.) was 52.4 % adults and 47.6 % juveniles (95 % confidence intervals for $juv\% = 42.99\text{--}52.21$). The mean brood size could not be determined due to problems in identifying family groups in the flocks.

3.2. Kurgaldzhino–Tengiz region

The total number of geese counted during the survey was c. 500,700 individuals (Table 3). The random sampling of the species proportion resulted in a sample data set of 26,340 ind. (878×30 individuals), i.e. 5.3% of the total number of geese in the survey. Only for the lakes Zhylandyshalkar and Kumkol (which hosted 5.0% of all geese counted in the region) no sample data was obtained. The largest concentrations were observed at Lake Kubikol and Lake Shandykol.

Based on the sample data from the lakes where adequate sample data was obtained (see Table 3), the estimated total number of LWfG in the survey was c. 940 individuals (0.19% of the total number of geese, see Table 3). For the Red-breasted Goose, the corresponding estimate was c. 8,300 individuals (1.7% of the total). More than 89% of the geese seen in the survey were White-fronted Geese, and Greylag Goose accounted for 6% (Table 3). Applying the weighted mean proportion of the species at the other lakes for Lake Zhylandyshalkar (where 15,800 geese were counted but no samples obtained), the corresponding total estimates for the whole area were somewhat higher: LWfG 970 individuals and Red-breasted Goose c. 8,600 individuals (Table 3).

In addition to the four species shown in Table 3, Bean Geese of both tundra (*A. f. rossicus*) and taiga (*A. f. fabalis*) forms, and nominate race Brent Geese were recorded. For Bean Goose, an estimate of c. 90 individuals in the survey was derived from 3

Table 2. Total numbers (counts) of geese in the surveyed roosting lakes in the Kustanay region, proportions of the four most numerous goose species based on random sample data, and respective estimates of number of individuals. For the lakes Batpakkol, Kulakol, Kushmurun, Bozshakol, Sarykol and for other places where no sample data was obtained and no rough estimate of species proportion was made in the field, a weighted mean of the proportion of these species at the sampled lakes was applied (marked with * in the table). The estimates for each species were achieved by using these weighted mean proportions. Because of the clear difference in the species proportions between the southern and northern parts of the area, the species proportions were calculated separately in the southern and northern parts. The weighted mean of the southern lakes Kulykol and Ayke was applied for Lake Batpakkol, and the weighted mean of the northern lakes Koybagar and Tyuntyugur was applied for the lakes Bozshakol and Sarykol and for other places. The numbers of individuals in **bold** (counts for the lakes Kulakol and Tali) are not estimates but direct counts, and for these two lakes the percentages of each species are calculated directly from these counts. For the sampled lakes, the 95% confidence intervals for species proportion estimates and for the corresponding estimates of the number of individuals are given below the estimates.

Lake	Total no. of geese	no. ind. sampled	Anser albifrons		Anser anser		Anser erythropus		Branta ruficollis	
			%	estimate	%	estimate	%	estimate	%	estimate
Kulykol	86,000	10,950	65.91	56,700	8.44	7,260	2.15	1,850	23.50	20,200
95% c.i.:			65.02–66.80	55,900–57,400	7.92–8.96	6,810–7,710	1.88–2.42	1,620–2,080	22.71–24.29	19,500–20,900
Ayke	60,000	3,210	78.04	46,800	9.78	5,870	2.09	1,250	10.10	6,060
95% c.i.:			76.61–79.47	46,000–47,700	8.75–10.81	5,250–6,490	1.60–2.58	960–1,550	9.06–11.14	5,440–6,690
Batpakkol	30,000	*0	*82.1	*24,600	*10.4	*3,120	*2.5	*740	*5.0	1500
Kulakol	550	0	36.36	200	54.55	300	0	0	9.09	50
Kushmurun	1,500	*0		*1,040		*120		*1		*360
Koybagar	33,000	3,000	55.67	18,400	10.93	3,610	0.07	22	33.33	11,000
95% c.i.:			53.89–57.45	17,800–19,000	9.81–12.05	3,240–3,980	0–0.16	0–54	31.64–35.02	10,400–11,600
Tyuntyugur	25,000	3,240	84.81	21,200	3.83	960	0.06	15	11.30	2,820
95% c.i.:			83.57–86.05	20,900–21,500	3.17–4.49	790–1,120	0–0.14	0–36	10.21–12.39	2,550–3,100
Bozshakol	8,000	*0	*68.2	*5,460	*7.9	*630	*0.06	*5	*23.8	1,900
Sarykol	400	*0	*68.2	*270	*7.9	*32	*0.06	*0	*23.8	*95
Tali	1,100	0	77.27	850	18.18	200	0	0	4.55	50
Other places	1,000	*0	*68.2	*680	*7.9	*79	*0.06	*1	*23.8	*240
Total	246,550	20,400		176,200		22,200		3,880		44,300

individuals in the sample material (0.02% of the total) – altogether 9 Bean Geese were observed, 3 of them identified as rossicus-type and 3 of fabalis-type. Two Brent Geese of the nominate race bernicla were seen (one at Lake Kubikol 6 October, and one at Lake Sholak 13 October) – the latter of these happened to be included in a random sample.

The total sample size for the age ratio of White-fronted Goose was 13,680 individuals (456 samples of 30 individuals), i.e. 3.16% of the estimated total number of White-fronted Geese. This sample data resulted in a proportion of 53.3% juvenile (1st-calendar year) birds (95 % confidence interval for juv% = 52.46–54.14). Due to the relatively low number of LWfG, the age ratio (or brood size) of LWfG could not be sampled in a similar way. In the species sample data, 16 out of the 62 LWfG identified by age were 1st-calendar year birds, which yields a juvenile proportion of 26 %.

3.3. Pooled results

Altogether, c. 747,000 geese were counted contemporaneously in the two survey areas. Of these, c. 4,850 ind. (0.65%) were estimated to be LWfG, c. 52,900 ind. (7.1 %) Red-breasted Geese, c. 54,300 ind. (7.3%) Greylags, and the majority, c. 635,200 ind. (85 %) were White-fronted Geese. The proportion of LWfG was considerably higher in the Kustanay region (1.6% of all geese), as compared with the Kurgaldzhino–Tengiz region (0.19%). The same applies for Red-breasted Goose (18.0% in the Kustanay region versus 1.7% in the Kurgaldzhino–Tengiz region). Data on the the brood size of LWfG is presented in Table 4.

4. Discussion

The results of the surveys ascertain the importance of the Kustanay region as the main autumn staging area for the western populations of LWfG and for the entire world population of Red-breasted Goose: the proportion and the estimate of the number of individuals for these two species were considerably higher in the Kustanay region as compared with the Kurgaldzhino–Tengiz region. However, much higher numbers of White-fronted Geese were counted in the Kurgaldzhino-Tengiz region. In the Kustanay region, the most important staging areas for LWfG are clearly located in the south-western part, with Lake Kulykol being the most important. In the Kurgaldzhino–Tengiz region, the lakes Korzhynkol (Baumanskoye), Shunkyrkol and Sholak hosted the highest proportions of LWfG,

Table 4. The brood size data of Lesser White-fronted Goose in different regions.

Brood type	Kustanay		Kurgaldzhino-Tengiz		Total
	1 ad	2 ad	1 ad	2 ad	
1 juv.	–	1	2	2	5
2 juv.	–	3	2	1	6
3 juv.	–	2	–	–	2
4 juv.	–	1	–	4	5
5 juv.	–	1	–	–	1
6 juv.	–	2	–	1	3
Total	–	10	4	8	22
mean juv. / brood		3.4		2.7	2.8
mean ad. / brood		2.0		1.7	1.8

although Lake Kubikol hosted the highest number of geese in total.

In the previous surveys in the Kustanay region in 1996 and 1998, numbers equalling c. 50% and up to more than 90% (Table 5) of the western population of LWfG (c. 8,500-17,000 ind. according to Lorentsen et. al. 1999) and up to 100% of the world population of Red-breasted Goose (70,000 ind. according to Hunter et al. 1999) have been estimated staging in the area in autumns 1996 and 1998 (Tolvanen & Pynnönen 1998, Tolvanen et al. 1999b). The lower total number of geese in Kustanay in 1999 region as compared with the years 1996 and 1998 (Table 5) might be a result of differences in timing of the migration of LWfG and Red-breasted Goose due to unusual warm weather in autumn 1999; possibly some part of the geese could still be staying in the more northern staging areas during the first half of October. However, in the Kurgaldzhino-Tengiz region, where G. Eichhorn continued the waterbird censuses until the beginning of November, the peak number of geese was observed during the LWfG survey (2–13 October), which does not support the assumption of late timing of the goose migration.

4.1. Kustanay region

In the Kustanay region, the total number of geese was somewhat less than during previous surveys. This difference is mainly due to a lower number of geese at Lake Kulykol, where remarkable concentrations were observed during the previous surveys: 120,000 ind. in October 1996 (Tolvanen & Pynnönen 1998) and 160,000 ind. in October 1998 (Tolvanen et. al 1999b). In the lakes visited both during the 1998 and 1999 surveys, considerably more birds were seen in 1999 at the lakes Batpakkol and Koybagar, while the figures

Table 3. Total numbers (counts) of geese at the surveyed roosting lakes in the Kurgaldzhino–Tengiz area, proportions of the four most numerous goose species based on random sample data, and respective estimates of numbers of individuals. For Lake Zhylandyshalkar, where no sample data was obtained and no rough estimate of species proportion was made in the field, a weighted mean of the proportion of these species at the sampled lakes was applied (marked with * in the table), and the estimates for each species was counted using these weighted mean proportions. For Lake Kumkol, a rough estimate for the species proportion was achieved without sampling in the field (marked with ** in the table). For the sampled lakes, the 95% confidence intervals for the species proportion estimate and for the corresponding estimate of the number of individuals are given below the values.

Lake	Total no. of geese	no. ind. sampled	Anser albifrons		Anser anser		Anser erythropus		Branta ruficollis	
			%	estimate	%	estimate	%	estimate	%	estimate
Zhylandyshalkar	15,800	0	*91.9	*14,500	*6.1	*970	*0.2	*31	*1.8	*277
Kumdykol & Ashi–Kumkol	11,800	330	96.97	11,400	3.03	360	0.00	0	0.00	0
:95% c.i.:			95.12–98.82	11,200–11,700	1.18–4.88	140–580	–	–	–	–
Kubikol	176,800	5,910	92.17	162,900	5.97	10,600	0.20	360	1.61	2,840
:95% c.i.:			91.49–92.85	161,700–164,200	5.37–6.57	9,480–11,600	0.09–0.31	150–560	1.29–1.93	2,280–3,410
Sochinskoye	35,300	1,080	92.01	32,500	4.83	1,710	0.19	66	2.97	1,050
:95% c.i.:			90.39–93.63	31,900–33,100	3.55–6.11	1,250–2,160	0–0.45	0–160	1.96–3.98	690–1,400
Baumanskoye	29,300	3,810	97.48	28,600	0.26	77	0.89	260	1.36	400
:95% c.i.:			96.98–97.98	28,400–28,700	0.10–0.42	29–124	0.59–1.19	170–350	0.99–1.73	290–510
Shandykol	115,300	6,150	87.14	100,500	9.50	11,000	0.03	37	3.33	3,840
:95% c.i.:			86.30–87.98	99,500–101,400	8.77–10.23	10,100–11,800	0–0.07	0–84	2.88–3.78	3,320–4,360
Shunkyrkol	10,000	1,080	98.70	9,870	0.56	56	0.74	74	0.00	0
:95% c.i.:			98.02–99.38	9,800–9,940	0.11–1.01	11–101	0.23–1.25	23–125	–	–
Alakol	35,300	1,290	91.86	32,400	8.06	2,850	0.08	27	0.00	0
:95% c.i.:			90.37–93.35	31,900–33,000	6.57–9.55	2,320–3,370	0–0.23	0–83	–	–
Burevestnik	49,700	3,390	98.61	49,000	0.94	470	0.15	73	0.29	150
:95% c.i.:			98.22–99.00	48,800–49,200	0.62–1.26	310–630	0.02–0.28	10–139	0.11–0.47	50–230
Kumkol	9,300	**0	**80	**7,440	**20	**1,860	**0	**0	**0	**0
Sholak	12,100	3,300	81.76	9,900	17.48	2,120	0.33	40	0.39	48
:95% c.i.:			80.44–83.08	9,700–10,100	16.18–18.78	1,960–2,270	0.13–0.53	16–64	0.18–0.60	21–73
Total	500,700	26,340		459,000		32,100		970		8,600

for the lakes Ayke and Bozshakol, together with the combined figure for the Tyuntyugur–Zhanshura–Biesoygan lake system were rather similar to 1998 (cf. Tolvanen et al. 1999b).

The percentage and total number of LWfG this year was markedly lower as compared with the 1996 and 1998 surveys (Table 5). Nearly all LWfG were seen at the two southern lakes; Kulykol and Ayke, both already known to be very important staging areas for the species. Both of these lakes differed to some extent from the other lakes in lacking extensive reed beds on the shores. The relative proportion of White-fronted Geese was much higher and those of Greylag and Red-breasted Geese were lower than in autumn 1996, but closer to the level of autumn 1998 (Table 3, cf. Tolvanen et al. 1999b).

The estimates derived for Lake Batpakkol are based on calculated weighted means of the proportions of *Anser* geese at the lakes Kulykol and Ayke, without any actual sample data set from this lake. Thus, the estimates for *Anser* species at Lake Batpakkol have to be treated with caution.

4.2. Kurgaldzhino–Tengiz region

For the Kurgaldzhino–Tengiz region, comparison of the 1999 data with previous surveys is not possible. However, the area is known as a traditional stop-over for migrating arctic geese (Vinogradov 1990), and the results of this survey confirm that this area is still a very important autumn staging area for White-fronted Geese, and (although not as important as the Kustanay region) also for LWfG and Red-breasted Goose, numbers equalling c. 6% of the western population of LWfG (current estimate c. 15,000 ind., Lorentsen et al. 1999) and c. 12% of the world population of Red-breasted Goose (70,000 ind. according to Hunter et al. 1999) were estimated in the area during the survey.

4.3. Breeding success of LWfG and White-fronted Goose

The results indicate a very successful breeding season for White-fronted Geese, and a relatively high juvenile proportion also for LWfG (Table 5). This is another indication supporting the assumption that in general the juvenile production of LWfG populations is high, and that the reason for the population decline is due to high (hunting) mortality during the migration and wintering periods (Tolvanen et al. 1999a). In Kustanay region the mean brood size of observed LWfG broods was 2.0 ad and 3.4 juv (n = 10 broods) and in the Kurgaldzhino–Tengiz region 1.7 ad and 2.7 juv (n = 12 broods) (Table 4).



Photo. An adult Lesser White-fronted Goose (second from right in the lower row) in a flock of White-fronted Geese at Lake Korzhynkol, Kazakstan © Petteri Tolvanen, October 1999

4.4. Conservation status and hunting control

The main threats for LWfG in the region are hunting and disturbance at the staging areas. LWfG is not yet protected in Kazakstan, although a proposal to include the species in the Red Data Book of Kazakstan has been made.

None of the surveyed roosting lakes or feeding areas in either of the regions is included in nature reserves. Around most of the lakes in both areas, local hunting inspection has established 500–1500m wide hunting-free zones. The main reason for the establishment of these hunting-free zones, however, is not the conservation of the geese, but to avoid scaring of the roosting geese and other waterfowl away to other roosts for hunting purposes. For the same reason, hunting of geese is normally forbidden in some weekdays during the hunting season.

Hunting regulations of geese vary between different lakes and between years. In 1999 in the Kustanay region, the open season for goose hunting was 28 August – 8 November, but hunting of LWfG

was forbidden by a regional decision between 20 September and 8 November at some lakes (incl. Lake Kulykol, Lake Tyutyugur and some other lakes in the Turgay depression). In practice, however, these protective measures are not very effective for LWfG conservation due to the difficulties of separating LWfG and White-fronted Geese in flight. Another major problem for the protection of the geese in this region is that the hunting inspection authorities do not have sufficient resources to control the lakes, and the administrative position of the hunting inspection is unstable. The re-establishment of a bonus for conviction of poachers could possibly help to intensify the hunting control system. Although the number

of active hunters has officially decreased (in the Kustanay region from c. 14,000 hunters in 1997 to the present c. 4,500 hunters), illegal hunting seems to be a problem at least at some lakes. In October 1999, especially heavy hunting was noticed at the lakes Koybagar and Tyutyugur in the Kustanay region.

In the Kustanay region, economical difficulties have resulted in dividing the regional Fish, Forest and Hunting Committee (i.e. the regional authority responsible for hunting control) into two departments, and at the same time the staff has decreased from 80 to 16. The Business Department of the committee is specialising in raising money by promoting hunting tourism for foreign hunters,

Establishment of a network of protected areas for waterfowl and other wetland birds in north-western Kazakhstan

The lakes of the forest steppes and steppes of northern Kazakhstan are one of the most important areas for concentrations of migratory waterfowl in Eurasia. Huge numbers of geese, ducks, gulls, cranes and other birds pass through the area in spring and especially in autumn. The general ecological conditions in the wetlands are favourable for waterfowl, but on the other hand, the recent status of some wetlands in the area can be characterised as unsustainable because of increased human pressure, like hunting, fishing and cattle breeding. The list of migratory bird species of the wetlands in the Kustanay region includes several rare and particularly important species like the Lesser White-fronted Goose (*Anser erythropus*), Red-breasted Goose (*Branta ruficollis*), White-headed Duck (*Oxyura leucocephala*), Siberian White Crane (*Grus leucogeranus*), and possibly even the extremely rare and endangered Slender-billed Curlew (*Numenius tenuirostris*). The necessity to conserve the breeding, moulting and staging habitats of endangered species as well as game species has been the main purpose of the programme presented below.

In 1999–2000, WWF International took the initiative to fund a project in order to establishment of a network of protected wetlands in north-western Kazakhstan. The project was devoted to:

- survey and monitoring of the key wetlands of north-western Kazakhstan
- analysis of existing data from different sources and field research
- preparation, approval and further establishment of a network of protected areas, including the most important breeding and staging habitats for waterfowl.

The objectives of the project were:

- to gather and analyse data on the main conservation areas for breeding and migratory waterfowl species from northern Europe
- preparation of a survey of the key wetlands, with an analysis of their status, existing and potential threats, including land use conflicts in surrounding areas
- identification of the necessary measures for conservation of migratory waterfowl concentrations in each area, preparation of a well founded proposal on conservation of different areas
- recommend establishing of a network of protected areas, including new areas and extension of existing ones, e.g. the Naurzum Zapovednik
- preparation of necessary documents ("passports" for protected areas)
- adjustment and approval of the proposal by local authorities
- approval of the proposal by regional and national authorities

Progress in the second part of 1999

Field research was carried out in Kustanay and northern Kazakhstan regions in July 1999 (in the southern and northern groups of lakes by teams from Kustanay and Petropavlovsk regions) and in

September–October 1999 (including migration studies, description of lakes and water tests by field teams from Kustanay, Almaty and Petropavlovsk regions) including a joint expedition with Finnish Lesser White-fronted Goose specialists. Analysis of data from the most important areas for migratory waterfowl from northern Europe was continued, and the necessary measures for conservation of migratory and breeding waterfowl in each area were identified. The first part of the water samples is now analysed (salt concentration, N/P and radiation tests). Maps for all lakes of the northern Kazakhstan region were prepared. Necessary documents for new protected areas (northern Kazakhstan and Kustanay) and proposals for local, regional and national authorities were prepared. However, reorganisation of all levels of the nature management authorities of Kazakhstan has complicated continuation of these discussions.

Preparation of new documents for Sary-Copa Zakaznik (Kustanay region) and approval of the proposal for regional and national authorities is now finished. At present, this protected wetland includes more than 80,000 ha (increased by more than 30,000 ha) and is under the responsibility and protection of Naurzum Zapovednik. The preparation of a proposal for establishment of new protected areas in the territory of Naurzum Zapovednik and in northern Kazakhstan region was continued. In the Naurzum region, the local government have already signed (14 February, 2000) a decision to enlarge the Naurzum Reserve by 103,000 ha. On 9 February, 2000 the project co-ordinator had a new meeting in Kustanay with all stakeholders of Kustanay Oblast for other important sites. In addition, two regional TV-programs has been prepared by using video film material from the project group (the Kustanay team) and the Finnish Lesser White-fronted Goose survey team.

Needs and perspectives for a follow-up project

The analyses of water samples and vegetation descriptions are not yet finished for some wetlands because no scientific descriptions are available. There is also a need for additional field investigations. Surveys of breeding birds have not been carried out in all the regional wetlands due to shortage of time and limited economical resources. Funds for printing a publication on the key wetlands for waterfowl of the forest steppe and steppe regions of northern Kazakhstan would be needed. In general, there are good perspectives for implementation of this project because of a new conservation legislation for wetlands in Kazakhstan.

Tatyana M. Bragina

Project co-ordinator

459730 Kazakhstan, Kustanaiskaya Oblast, Naurzum Rayon,

Karamendy, Altynsarin Str., 45-1, tel. +7(314-54) 91838

e-mail: naurzum@krcc.kz



Photo. Lesser White-fronted Geese (one adult with one juvenile and two adults with three juveniles) with White-fronted Geese on the shore of Lake Korzhynkol, Kazakstan © Petteri Tolvanen, October 1999

which has resulted in an increased hunting pressure on geese.

In the Kurgaldzhino–Tengiz region there is a large nature reserve – The Kurgaldshinskiy Zapovednik. However, none of the important roosting lakes for geese in this region are situated inside the reserve. Inside the reserve all kinds of resource exploitation is forbidden, including agriculture. The German Society for Nature Conservation (NABU) has been working actively in the region since 1996, and now NABU and its partners in Kazakstan are preparing a biosphere reserve (in the framework of the UNESCO’s programme on Man and Biosphere) in the area around Lake Tengiz. The suggested biosphere reserve would include the whole territory of the Kurgaldshinskiy Zapovednik with some proposed enlargements as the core zone, surrounded by a buffer zone, and a zone of sustainable land use around the buffer zone. This area (including the buffer and sustainable land use zones) is almost ten times larger than the current reserve.

Formerly the Kurgaldshinskiy Zapovednik was to a much higher extent used by roosting geese. Also at that time cultivation inside the zapovednik was prohibited, but after the collapse of the Soviet Union, the wheat production decreased in the areas outside the reserve, especially in the climatic border zone south of Lake Tengiz. As a consequence, there is at present clearly less wheat fields close to the reserve, and therefore only a small proportion of the staging geese presently use the lakes inside the reserve as compared with the situation 10 years ago. Only when the geese arrive in the area, and at the end of their stay in the region, they use the large Lake Tengiz and other lakes inside the reserve in significant numbers. The most important roosting lakes are situated in the area to the north of the reserve.

The hunting and disturbance pressure for geese in the Kurgaldzhino–Tengiz region is clearly higher than in the Kustanay region. This is mainly due to the close localisation of the new capital Astana (only 120 km NE of Kurgaldzhino). There has been suggestions to transform the strictly protected Kurgaldshinskiy Zapovednik into a "national park" where hunting, fishing and other utilisation would be allowed. Furthermore, there is still plans e.g. to establish hunting clubs in the area for high authorities and wealthy citizens of Astana. Almost all of the surveyed important roosting

Table 5. Total numbers of geese, minimum estimates of total Lesser White-fronted Goose numbers and the juvenile proportion of LWfG in the Kustanay region in October 1996, 1998 and 1999. For the 1996 results, see Tolvanen & Pynnönen (1998); for the 1998 results, see Tolvanen et al. (1999b).

Period	Total no. of geese	LWfG number (min estimate)	LWfG juv %
4–15 October, 1996	280,000	7,900	33.3
5–16 October, 1998	293,000	7,300	43.3
1–13 October, 1999	247,000	3,880	43.9

lakes in the Kurgaldzhino–Tengiz region are rented by private hunting companies (e.g. Lake Kubikol rented by the company ‘Chesna’) or privately owned (e.g. Lake Shandykol), and we recorded a heavy hunting pressure on geese at these lakes. Also at most of these lakes, up to 1,500 m broad hunting free zones around the lakes have been established. In the Kustanay region, altogether c. 110 lakes have been rented for fishing, which has resulted in increased disturbance of geese, but at the moment the private hunting business has not yet been established in this region.

In addition to the urgent need for direct conservation efforts at the most important staging places of LWfG and Red-breasted Goose, there evidently is need for further public awareness campaigns and educational work to inform about the endangered status of the LWfG for local hunters. Many hunters and even hunting inspectors e.g. erroneously identify young White-fronted Geese as LWfG. During the surveys, awareness on the critical situation of LWfG was highlighted by distributing stickers and posters in Russian and Kazakh languages (see Øien et al. 2000, p. 57–58 in this report), and by giving interviews in the local television channel and newspaper.

5. Acknowledgements

We would like to thank Murat Aytjanov, the director of the Kurgaldzhinskiy Zapovednik for the arrangements in the Kurgaldzhino–Tengiz area. Transportation was provided by The Forest, Fish and Hunting Inspection Committee of the Kustanay Region, and by Ivan Luft from the Kurgaldzhinskiy Zapovednik. The help of Tatyana Bragina and Evgeny Bragin from Naurzum Zapovednik was

indispensable in the arrangements and during the field work in the Kustanay region, and Sami Timonen and Aki Arkiomaa both did a good job in the Kustanay survey team.

References

- Gurtovaya, E., Tolvanen, P., Eskelin, T., Øien, I.J., Bragina, T., Aarvak, T., Eichhorn, G., Arkiomaa, A. & Timonen, S. 1999:** Preliminary results of the Lesser White-fronted Goose monitoring in Kazakstan in October 1999. – *Casarca* 5:145–154. (In Russian with English summary)
- Hunter, J.M., Black, J.M., Rusev, I., Michev, T. & Munteanu, D. 1999:** Red-breasted Goose (*Branta ruficollis*). In: Madsen, J., Cracknell, G. & Fox, A.D. (eds.): *Goose populations of the Western Palearctic. A review of status and distribution.* – Wetlands International Publ. No. 48, Wetlands International, Wageningen, The Netherlands. National Environmental Research Institute, Rønde, Denmark. Pp. 328–340.
- Lorentsen, S.-H., Øien, I.J., Aarvak, T., Markkola, J., von Essen, L., Farago, S., Morozov, V., Syroechkovsky Jr., E. & Tolvanen, P. 1999:** Lesser White-fronted Goose (*Anser erythropus*). In: Madsen, J., Cracknell, G. & Fox, A.D. (eds.): *Goose populations of the Western Palearctic. A review of status and distribution.* – Wetlands International Publ. No. 48, Wetlands International, Wageningen, The Netherlands. National Environmental Research Institute, Rønde, Denmark. Pp. 144–161.
- Markkola, J., Pynnönen, P., Tolvanen, P., Veersalu, A. & Yerohov, S. 1998:** The second international Lesser White-fronted Goose Anser erythropus expedition in NW Kazakstan in May 1997. In: Tolvanen, P., Ruokolainen, K., Markkola, J. & Karvonen R. (eds.): *Finnish Lesser White-fronted Goose Conservation Project. Annual report 1997.* – WWF Finland report 9:21–22.
- Øien, I.J., Tolvanen, P., Aarvak, T., Litvin, K.E. & Markkola, J. 1999:** Surveys and catching of Lesser White-fronted Geese at Taimyr Peninsula 1998 - preliminary results on autumn migration routes mapped by means of satellite telemetry. In: Tolvanen, P., Øien, I.J. & Ruokolainen, K. (eds.): *Fennoscandian Lesser White-fronted Goose conservation project. Annual report 1998.* – WWF Finland Report 10 & Norwegian Ornithological Society, NOF Rapportserie Report no 1-1999:37–41.
- Øien, I. J., Kostadinova, I. & Aarvak, T. 2000:** Status on the awareness campaign for the Lesser White-fronted Goose. In: Tolvanen, P., Øien, I. J. & Ruokolainen, K. (eds.): *Fennoscandian Lesser White-fronted Goose Conservation Project. Annual report 1999.* – WWF Finland Report 12 & Norwegian Ornithological Society, NOF Rapportserie Report no. 1-2000:57–58.
- Tolvanen, P. & Pynnönen, P. 1998:** Monitoring the autumn migration of Lesser White-fronted Goose Anser erythropus and other geese in NW Kazakstan in October 1996. In: Tolvanen, P., Ruokolainen, K., Markkola, J. & Karvonen R. (eds.): *Finnish Lesser White-fronted Goose Conservation Project. Annual report 1997.* – WWF Finland Report 9:19–20.
- Tolvanen, P., Markkola, J., Aarvak, T. & Øien, I.J. 1999a:** Introduction. In: Tolvanen, P., Øien, I. J. & Ruokolainen, K. (eds.): *Fennoscandian Lesser White-fronted Goose conservation project. Annual report 1998.* – WWF Finland Report 10 & Norwegian Ornithological Society, NOF Rapportserie Report no. 1-1999:5–8.
- Tolvanen, P., Litvin, K. E. & Lampila, P. 1999b:** Monitoring the autumn staging of Lesser White-fronted Goose in north-western Kazakstan, October 1998. In: Tolvanen, P., Øien, I. J. & Ruokolainen, K. (eds.): *Fennoscandian Lesser White-fronted Goose conservation project. Annual report 1998.* – WWF Finland Report 10 & Norwegian Ornithological Society, NOF Rapportserie Report no. 1-1999:42–46.
- Tolvanen, P., Pynnönen, P., Markkola, J., Aarvak, T. & Øien, I.J. 1999c:** Monitoring instructions for Lesser White-fronted Goose surveys. In: Tolvanen, P., Øien, I.J. & Ruokolainen, K. (eds.): *Fennoscandian Lesser White-fronted Goose Conservation Project. Annual report 1998.* – WWF Finland Report 10 & Norwegian Ornithological Society, NOF Rapportserie Report no. 1-1999:68–71.
- Vinogradov V. G. 1990:** Anser erythropus in the USSR. In: Matthews, G. V. T. (ed.): *Managing Waterfowl Populations.* – Proc. IWRB Symp., Astrakhan 1989. IWRB Spes. Publ. 12, Slimbridge, UK:199–203.

Occurrence of the Lesser White-fronted Goose in Spain, up to 1999

Hakon Persson

Department of Animal Ecology, Ecology Building, S-223 62 Lund, SWEDEN

Spain is, indeed, not a country one associates with the Lesser White-fronted Goose (*Anser erythropus*, later LWfG). And the available material up to 1984 is, in fact, extremely scanty. Pascual Madoz (1848) reported the occurrence of three kinds of geese in Laguna de la Nava, without identifying the birds to species. In the South Spanish marshes, primarily the Guadalquivir Marismas, three goose species were reported to occur in the second half of the 19th century (Chapman & Buck 1893). The Greylag Goose (*A. anser*) was the principal one, followed by the less numerous Tundra Bean Goose (*A. fabalis rossicus*). The LWfG seemed to occur as well, as Lord Lilford, who possessed individuals hunted in the province of Sevilla, mentioned that he had seen one individual together with Greylags. As for the other European goose species, there were no evidence that they reached southern Spain in winter. Francisco Bernis (1966) knew about only three sporadic captures of LWfG in Iberia, lending the species status of being very rare in Spain in winter (Bernis 1972). Later, one adult was captured in the Guadalquivir Marismas on the 5th of March 1971 (Hidalgo & Rodríguez 1972).

The LWfG has been more frequently observed during the last 15 years, especially in Doñana National Park and Doñana Natural Park (Table 1). García et al. (1989) estimated that at least 15 individuals were present in the Guadalquivir Marismas during the winter 1985/86. For the same area, Llandres & Urdiales (1990) described the LWfG as a very scarce winterer, which could be observed from the beginning of December to the middle of February. Based on intensive field work in all main areas in Spain, the number of wintering LWfG was estimated to be on average one individual during the three winters 1989/90 to 1991/92 (Persson 1995a, 1995b). Accordingly, the number of LWfG in Spain during the last 15 years has showed marked among-winter fluctuations, ranging from one single individual to at least 15.

The almost total lack of data up to 1984 invites speculation. To use that as a justification to count the LWfG as a mere vagrant in Spain is, however, to jump to conclusions. If the LWfG was a regular wintering bird in Spain, its winter quarters were most likely situated in steppe areas in the central or north-central part of the country, where large numbers of geese wintered. Bernis et al. (1964) wrote, for instance, about the core area (in translation from Spanish): "It is more than likely that at times not so long ago, hundreds of thousands of geese wintered in the Duero Basin". When these geese attracted the attention of scientists in the early 1960s, the major decline had already occurred, and only a few thousand wintering Tundra Bean Geese remained (Bernis 1964). Since then, the Tundra Bean Goose has disappeared from Spain altogether (Persson & Urdiales 1995). It is more than likely that substantial numbers of LWfG could have passed unnoticed in these multitudes, especially as hunting was of little significance (Bernis et al. 1964).

One reason for the sharp rise in the number of observations during the last 15 years is, of course, that birds from the Swedish re-establishment project (von Essen 1996) turned up in Spain. Another important factor is that the Nordic Greylag Goose Project was launched in 1984 (Nilsson et al. 1993). As from 1985 it pays to check the large flocks of Greylag Geese carefully for the occurrence of neck-collared individuals. This much is certain that it is not easy to spot a LWfG in the Guadalquivir Marismas. In fact, several of the individuals included in Table 1 were heard long before they were sighted, while others were only heard.

Restoration and protection of wetlands in the Duero Basin, first at Villafáfila (Palacios & Rodríguez 1989), then at Laguna de la Nava (Jubete 1991), offered geese safe roosts in this formerly so important wintering area. The first to react positively on these measures was the Norwegian Greylag Goose population. More than half of the

Table 1. Records of Lesser White-fronted Geese in Spain, 1985–1999. All localities, except Villafáfila, are situated in the Guadalquivir Marismas. Observations marked with * are the only ones accepted by the Spanish Rarities Committee so far (Eduardo de Juana, pers. comm). cr = colour-ringed.

Date	Number of individuals	Locality	Observer/Reference
Nov 1985	1 group, with <i>B. leucopsis</i>	Marisma del Rocío	Local bird-watchers
19 Nov – 20 Dec 1985	1 ad cr + 1 ad unmarked	Boca del Lobo	Luis García
20–21 Dec 1985	1 ad colour-ringed	Boca del Lobo	Hakon Persson
23 Dec 1985	1 ad colour-ringed	Coto del Rey	Hakon Persson
7 Feb 1986	1 ad cr, with <i>B. leucopsis</i>	Boca del Lobo	Luis García
19 Jan 1988	1 ind	Villalobos	Luis García
2–24 Feb 1988	1 ad	Matasgordas/Coto del Rey	Luis García
24 Feb 1988	1 ad	Guadimar	Luis García
2 Jan 1989	3 ad + 4 juv + 2 ind	Coto del Rey	Luis García
5–7 Jan 1989	1 juv	Coto del Rey	Luis García
12 Jan 1989	4 ind	Cangrejo Grande	Pablo Pereira
16 Jan 1989	1 ad	Coto del Rey	Luis García
27 Jan 1989	1 juv colour-ringed	Cangrejo Grande	Luis García
24 Dec 1989 – 26 Feb 1990	1 juv unmarked	Hato Ratón/Guadimar	Hakon Persson
13 Nov 1990	1 ind	Hato Blanco	Hakon Persson
25 Nov – 3 Dec 1991	1 juv	Boca del Lobo	Hakon Persson
11 Dec 1991	1 juv unmarked	Marisma de Hinojos	Hakon Persson
Feb 1992	2 ind	Villafáfila	Sanz-Zuasti et al. 1997
Nov 1993	4 ind	Villafáfila	Sanz-Zuasti et al. 1997
1 Dec 1993	1 ind	Boca del Lobo	Hakon Persson
24 Jan 1994	1 ad unmarked	Hato Barrera	Hakon Persson
6–18 Jan 94	1 ad unmarked	Villafáfila	Hakon Persson
11–16 Feb 1994	1 juv unmarked	Villafáfila	Hakon Persson
24 Nov – 5 Dec 1994	1 ind	Boca del Lobo	Hakon Persson
Jan 1996	1 ind	La Nava Lagoon	Sanz-Zuasti & Velasco 1999
Dec 1997	2 ind neck-collared	Marisma de Hinojos	Markkola et al. 1999
27 Jan 1998	2 ind	Marisma de Hinojos	Hakon Persson
11 Feb 1998	1 ind	Los Caracoles	Hakon Persson
*25–26 Feb 1998	1 ad	La Nava Lagoon	Enrique Gómez Crespo
*23 Dec 1998	1 ad	Boada Lagoon	Enrique Gómez Crespo
23 Oct 1999	4 ind, with 1 <i>B. leucopsis</i>	Villafáfila	Gunnar Brusewitz

Norwegian population can be found now in this area in winter (pers. obs.). The Duero Basin is very likely more suitable for wintering LWFg than those sites in The Netherlands currently used by birds from the Swedish re-establishment project (von Essen 1999). However, to re-locate these birds to Spain is absolutely out of the question as long as the hunting pressure on geese in France is as high as it is today (cf. Persson 1999).

References

- Bernis, F. 1964:** La invernada y migración de nuestros Ansares (*Anser anser* y *Anser fabalis*). – *Ardeola* 9:67–109. (In Spanish)
- Bernis, F. 1966:** Aves Migradoras Ibéricas. Fasc. 2. – SEO, Madrid. (In Spanish)
- Bernis, F. 1972:** Breve reseña geográfica, migratológica y demográfica sobre algunas aves acuáticas censadas. – *Ardeola* 17–18:207–230. (In Spanish)
- Bernis, F. y colaboradores 1964:** Información Española sobre Anátidas y Fochas (Epoca Invernal). – Publicaciones de la Sociedad Española de Ornitología, Madrid. 154 pp. (In Spanish)
- Chapman, A. & Buck, W. J. 1893:** Wild Spain. – Journey and Jackson, London.
- von Essen, L. 1996:** Reintroduction of Lesser White-fronted Goose (*Anser erythropus*) in Swedish Lapland (1981–1991). In: M. Birkan, J. van Vesseem, P. Havet, J. Madsen, B. Trolliet & M. Moser (eds.): Proc. of the Anatidae 2000 Conf., Strasbourg, France, 5–9 December 1994. – *Gibier Faune Sauvage, Game Wildl.* 13:1169–1180.
- von Essen, L. 1999:** The Swedish reintroduction project of Lesser White-fronted Geese. In: Tolvanen, P., Øien, I.J. & Ruokolainen, K. (eds.): Fennoscandian Lesser White-fronted Goose conservation project. Annual report 1998. – WWF Finland Report 10 & Norwegian Ornithological Society, NOF Rapportserie Report no. 1–1999:53–55.
- García, L., Calderón, J. & Castroviejo, J. 1989:** Las Aves de Doñana y su Entorno. – Sociedad Cooperativa Andaluza “Marismas del Roció”. 136 pp. (In Spanish)
- Hidalgo, J. & Rodríguez, P. 1972:** Captura de un *Anser erythropus* en las marismas del Guadalquivir. – *Ardeola* 16:254–255. (In Spanish)
- Jubete, F. 1991:** La nueva laguna de la Nava. – *Quercus* 64:26–29.
- Llandres, C. & Urdiales, C. 1990:** Las Aves de Doñana. – Lynx Edicions, Barcelona. 124 pp. (In Spanish)
- Madoz, P. 1848:** Diccionario Geográfico-Estadístico-Histórico de España y sus posesiones de Ultramar. Tomo XII. – Establecimiento literario tipográfico de P. Madoz y L. Safareta, Madrid. (In Spanish)
- Markkola, J., Timonen, S. & Nieminen, P. 1999:** The Finnish breeding and restocking project of the Lesser White-fronted Goose: results and the current situation in 1998. In: Tolvanen, P., Øien, I.J. & Ruokolainen, K. (eds.): Fennoscandian Lesser White-fronted Goose conservation project. Annual report 1998. – WWF Finland Report 10 & Norwegian Ornithological Society, NOF Rapportserie Report no. 1–1999:47–50.
- Nilsson, L., Andersson, Å., Follestad, A. & Persson, H. 1993:** Observations of neck-banded Nordic Greylag Geese (*Anser anser*) during 1989/90. – *Seevögel* 14(1):14–17.
- Palacios, J. & Rodríguez, M. 1989:** Las Salinas de Villafáfila, Revellinos y Villarrín (Zamora). Censo y Obras de Recuperación. – *Vida Silvestre* 65:46–50. (In Spanish)
- Persson, H. 1995a:** Gansos. ¿Cuántos invernan en España? – *Trofeo* 296:80–87. (In Spanish)
- Persson, H. 1995b:** Geese wintering in Spain. (In Spanish with English summary). – *Quercus* 109:19–22.
- Persson, H. 1999:** La chasse à l’Oie cendrée *Anser anser* en France; ou de l’exploitation excessive d’une ressource naturelle. – *Alauda* 67:223–230. (In French with English summary)
- Persson, H. & Urdiales, C. 1995:** The disappearance of the Tundra Bean Goose *Anser fabalis rossicus* from the Iberian Peninsula. – IWRB Goose Research Group Bulletin 6:17–19.
- Sanz-Zuasti, J., Velasco, T. & Sánchez, C. 1997:** Guía de las Aves de las Lagunas de Villafáfila y su Entorno. – Asociación para el desarrollo rural integral A.D.R.I. “Palomares”. 212 pp.
- Sanz-Zuasti, J., Velasco, T. & Sánchez, C. 1999:** Guía de las Aves de Castilla y León. Valladolid: Junta de Castilla y León. XX pp. (In Spanish)

The Swedish project on re-establishment of the Lesser White-fronted Goose in Swedish Lapland – a summary for 1999

Lambart von Essen¹, Anders Bylin² & Bo Fagerström³

¹Fågelvik, Ludgo, S-61191 Nyköping, SWEDEN

²Stockholms Universitet, Tovetorps forskningsstation, S-64050 Björnlunda, SWEDEN

³Dalgatan 10, S-82442 Hudiksvall, SWEDEN

In winter 1998/1999 ca. 75 Lesser White-fronted Geese (*Anser erythropus*, later LWfG) of Swedish re-introduced origin were wintering in The Netherlands. Of these birds, 56 were colour-ringed. At the most frequented wintering site, Petten in Noord-Holland, we counted at least 28 individuals. Also a Barnacle Goose (*Branta leucopsis*) pair, that has been wintering there for four years in succession, was present together with five of their six LWfG juveniles. They started to use this wintering site together with their LWfG foster juveniles in 1995. Unfortunately, a LWfG was reported shot at Petten in November (a male released in 1997).

During spring 1999, some LWfG were seen at staging sites in Central Sweden. At Öster-Malma (i.e. the education centre for the Swedish Association for Hunting and Wildlife Management, and the reproduction site for the captive LWfG), 14 geese were staging for ca. one month until they went on and were seen in Lapland two days after they left Öster-Malma. A very favourable meadow area before the geese enter their home range in the mountains was used by about 35 individuals. An old farmer and his wife living in the area were

able to identify most of them.

In June, we were in the release area looking for the geese and trying to reveal if any of them were breeding. Like 1998, also this spring was fairly cold and late. However, we found 36 ringed and ca. 10 unringed LWfG. We found three breeding pairs, and when returning in July we found that one of the breeding pairs was "Limping Lotta" and her mate (see von Essen et al. 1993). When we observed them, they had only one gosling, but anyway she had carried through the breeding at the age of 10 years, and limping since she was three years old. Of course, when finding the brood on 9 July, we were happy and we had an extra drink in our cottage. Nevertheless, that day was the last time she was sighted. In the beginning of September, she did not arrive to Hudiksvall as she usually has done. During the moult she probably had been preyed upon by an Eagle or a Red Fox – ending the life of this remarkable and brave bird. She bred successfully four times and in total she produced eight fledglings.

Also another nest in the breeding area hatched successfully, and the brood of three juveniles seen in September at Hudiksvall, and at



Photo. A flock of Lesser White-fronted Geese of Swedish reintroduction origin in Swedish Lapland. © Anders Bylin, June 1999

Table 1. Survival (minimum figures) of Lesser White-fronted Geese released as goslings at Svaipa in Swedish Lapland (NL = Netherlands, W = winter and S = summer). The goslings are released at the age of about six weeks in July. Sightings are reported up to 15 October, 1999.

Year	Number	Cumul. Sum	South Sweden	NL 1st W	Lapland 2nd S	NL 2nd W	Lapland 3rd S	NL 3rd W	Lapland 4th S	NL 4th W	Lapland 5th S
1995	20	20	18	12	12	10	9	10	10	9	9
1996	21	41	21	18	13	14	12	10	7	–	–
1997	22	63	21	21	13	13	5 (+7*)	–	–	–	–
1998	18	81	15	15	11	–	–	–	–	–	–
1999	11	92	10	–	–	–	–	–	–	–	–
Total	92	–	85	66	49	37	33	20	17	9	9
Mean			92 %	82 %	60 %	59 %	52 %	49 %	41 %	45 %	45 %

*Observed only in central Sweden in autumn

Petten in The Netherlands 5 January 2000. In addition, at least one nest in the breeding area was found preyed upon, probably by a Raven (*Corvus corax*). A pleasant surprise was the observation of a brood of two ringed parents with six unringed juveniles in Central Sweden on 10 September. The male was three and the female four years old. This is the biggest brood of the totally 23 successful breedings registered since the project started in 1981. This brood was seen at the Lake Tåkern in October, and on 20 November it was in Zuid-Holland in The Netherlands. At Lake Tåkern, also another brood of three young was sighted, which we had not seen in the release area. The parents were unringed.

The production of goslings at the Öster-Malma farm was this year not very good. We only got two pairs of Barnacle foster parents with 11 goslings (6 and 5) to release. However, we also had six 2nd calendar-year geese from last year to release. Of the 11 goslings, 10 were seen in southern Sweden during the autumn. In total, about 70 LWfG were seen in southern Sweden during autumn migration. The most frequented stop-over sites are Hudiksvall, Hjälstaviken (50 km NW Stockholm), Norrköping and Lake Tåkern. Thanks to reports from many bird watchers, especially in The Netherlands and Germany, migration routes, wintering sites and survival of the geese has been possible to follow up quite well. Thus, out of 20 geese which were released in 1995, 9 were reported from The Netherlands in winter 1998/1999, and they were also sighted in Lapland in summer 1999. Also remarkable is the high percentage of juveniles, which are fledged and seen in southern Sweden (Table 1).

Since 1997, 18 2nd calendar-year LWfG have been released together with broods of goslings with Barnacle Geese as foster parents. Out of five released in 1997 and seven in 1998, four have been reported seen in The Netherlands and only two (both females) were seen returned to Lapland. As from our experiences in the 1980s it seems that these 2nd calendar-year geese, that during the moult have been released to fly free for the first time, have not been imprinted on the area like the goslings have been when they began to fly. In 1998, some of the former breeding areas of LWfG were investigated, but in 1999, no inventories were carried through and no reports of LWfG outside the re-introduction area have appeared from ornithologists or local people.

References

- von Essen, L. , Ouweneel, G. L. & van den Berq, A. B. 1993:** Origin of colour-ringed Lesser White-fronted Goose at Strijen. – *Dutch Birding* 15:220–224. (In Dutch with English summary)
- von Essen, L. 1996:** Reintroduction of Lesser White-fronted Goose (*Anser erythropus*) in Swedish Lapland (1981–1991). – *Gibier Faune Sauvage, Game Wildl.* 13:1169–1180.
- von Essen, L. 1999:** The Swedish reintroduction project of Lesser White-fronted Geese. – In: Tolvanen, P., Øien, I. J. & Ruokolainen, K. (eds.): *Fennoscandian Lesser White-fronted Goose conservation project. Annual report 1998.* – WWF Finland Report 10 & Norwegian Ornithological Society, NOF Rapportserie Report no 1-1999:53–55.

Genetic composition of the captive Lesser White-fronted Goose population

Minna Ruokonen

Department of Biology, University of Oulu, P.O.Box 3000, FIN-90014 Oulu, FINLAND, e-mail: minna.ruokonen@csc.fi

1. Introduction

Captive breeding stocks of endangered species are kept as a gene bank to preserve the genetic information of a species, to collect ecological knowledge and to increase public awareness often with the ultimate purpose to preserve material for restocking/reintroduction programs as a conservation measure. From the conservation point of view, some aspects in the genetic composition of the stock are important. The amount of genetic variation is usually maximised by mixing different breeding groups and by manipulating the reproductive output of the captive individuals to avoid possible harmful effects caused by inbreeding. Also, the individuals used for restocking should be genetically close to the original wild population. This increases the chances for survival due to similar adaptive background and prevents outbreeding depression caused by mixing of differentially adapted stocks (Templeton 1986).

According to the international action plan, most of the emphasis in the conservation of the Lesser White-fronted Goose (*Anser erythropus*, later LWfG) should be put on the research and protection of the wild population (Madsen 1996). Although the Fennoscandian breeding population has shrunken to 30-50 breeding pairs (Lorentsen et al. 1999), maintenance of the captive LWfG population and restocking has been given a low priority status as conservation measures as long as the wild population is able to persist (Madsen 1996). However, in Finland attempts to restock the wild population have been carried out earlier by releasing captive LWfG close to the breeding areas of the wild individuals (Markkola et al. 1999). In

Sweden, a population of LWfG with captive origin has been reintroduced and maintained by using semi-captive Barnacle Geese (*Branta leucopsis*) as foster parents (von Essen 1996, 1999). As a means to improve the survival of the Swedish reintroduced birds, the traditional migration route has been changed to areas with lower hunting pressure.

The origin of the captive stock of LWfG in Finnish and Swedish farms is unknown, but can be traced to wildfowl farms in Britain, Germany and The Netherlands (Delacour 1954, von Essen 1996). According to Delacour (1954) the species has long been a favourite in captivity raised both by private farmers and in zoos for decades. To clarify the origin and the background of the captive individuals, the composition of the maternal lineages present in the Hailuoto farm stock was studied.

2. Material and methods

Altogether 15 captive LWfG from the Hailuoto farm, Finland (out of 28 individuals present in the stock in 1993), and six White-fronted Geese (*A. albifrons albifrons*) from Kazakstan, Bulgaria and Nenets Autonomous District (Russia) were analysed. The hypervariable fragment of the maternally inherited mitochondrial control region was sequenced for the study. The detailed methodology related to DNA isolation, PCR and sequencing have been described elsewhere (Ruokonen et al. 2000b, c). Additionally, mitochondrial haplotypes present in the wild LWfG populations were used for comparison of



Photo. 'Limping Lotta' at the age of nine years at Hudiksvall just before the moult in July 1998. © Bo Fagerström

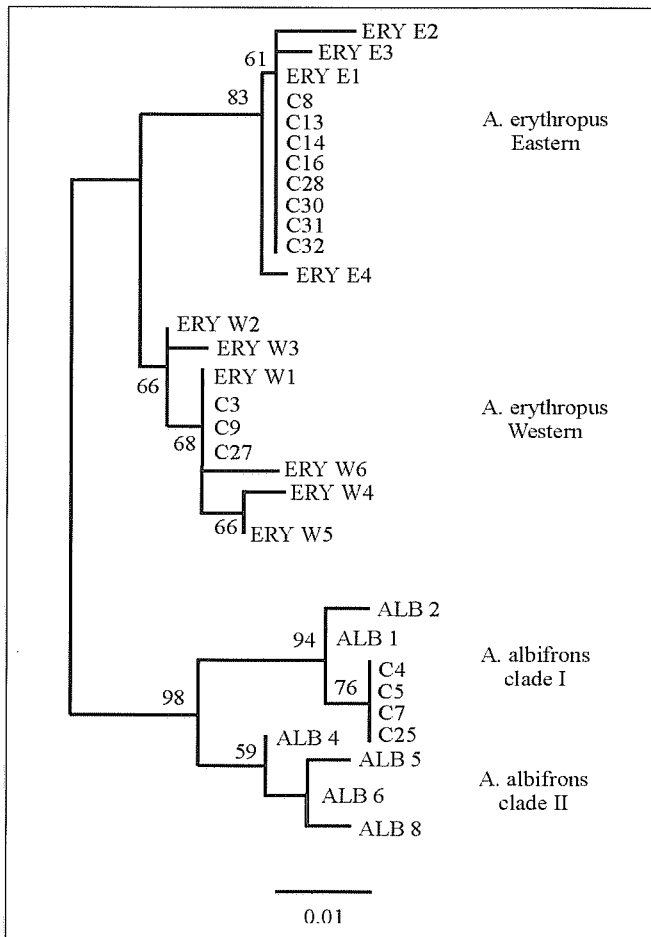

Figure 1. Neighbour-joining tree based on Kimura's 2-parameter distances among mtDNA control region haplotypes of the wild and captive LWfG and the White-fronted Geese based on the mtDNA control region sequences. Bootstrap values at the nodes are based on 500 replicates, only values above 50% are shown. ERY = Lesser White-fronted Goose, ALB = White-fronted Goose, C = captive Lesser White-fronted Goose.

the captive and the wild LWfG (Ruokonen et al. 2000a).

3. Results and discussion

Crucial for the successful planning of the conservation measures of a threatened species is the knowledge of the evolutionary history of the species and the degree of differentiation among the populations. Among the 15 individuals studied from the Fennoscandian wild population, three mitochondrial haplotypes have been found (Ruokonen et al. 2000a). One of the haplotypes is clearly prevalent (W1, 87%), the second haplotype was found only in one individual as well as the third one, which is found only in the Fennoscandian breeding population. The low amount of variation could be due to the recent decline of the population, but the analysis of prebottleneck individuals collected from museums suggests that Fennoscandia was colonized by a few individuals. The haplotype frequencies detected differ significantly between Fennoscandia and other breeding populations studied suggesting restricted amount of female gene flow among the breeding areas.

The phylogenetic relationships of the captive LWfG, wild LWfG and White-fronted Geese are shown in Figure 1. Three out of 15 captive LWfG (C3, C9, C27) were identical to the haplotype W1, which is the most common of the western haplotypes in the wild LWfG population. Eight captive individuals (C8, C13, C14, C16, C28, C30–32) represented the haplotype E1, which is the most common of the eastern haplotypes among the wild LWfG. However, four of the captive individuals (C4, C5, C7, C25) were placed together with the White-fronted Geese. The sequence of the captive individuals

differs from the sequence of White-fronted Goose haplotype ALB1 (Figure 1) by 0.45% or one nucleotide substitution.

LWfG carrying the mitochondrial DNA of the White-fronted Goose has not been found in the wild population (Ruokonen et al. 2000a), which suggests that the species is monophyletic with respect of mitochondrial DNA and that hybridisation between the two species is rare or does not lead to introgression. Because maternally inherited mitochondrial DNA is used as a marker, this conclusion applies to transfer of the White-fronted Goose mitochondrial DNA to LWfG through the offspring of a cross between a female White-fronted Goose and a male LWfG. Hybridisation between the two species is believed to be occasional in the natural populations (Nagy 1950, Panov 1989, Shackleton 1956), although difficult to detect reliably due to the great morphological similarity of the species. Furthermore, from the captive hybrids it is known that the morphological characters of the male parental species dominate: the hybrid offspring of a female White-fronted Goose and a male LWfG has a yellow eye-ring and a frontal patch typical for the LWfG (Nagy 1950).

In captivity, hybrids of LWfG with two *Anser* and three *Branta* goose species have been reported (Gray 1958). A cross between LWfG and White-fronted Goose is said to be fairly frequent and it has occurred in both directions. Therefore, a more probable explanation for the occurrence of the White-fronted Goose mtDNA in the captive LWfGs is that the hybridization has taken place at some point in the history of captive propagation.

Because the hybridisation was detected by the presence of heterospecific mtDNA in the captive stock and the history of the stock is unknown, it is not possible to estimate the proportion of heterospecific nuclear alleles in the stock and their effect directly. However, because the female is the heterogametic sex in avian species and the W chromosome is inherited linked to mtDNA to the female offspring, all the females carrying White-fronted Goose mtDNA in the captive population also have the W chromosome of White-fronted Goose. Some additional indirect indications for the presence of White-fronted Goose nuclear alleles in the captive stock exist: some of the individuals have unusually pale eye-rings or long and heavy bills or both (J. Markkola, pers. comm.). In a small population, such as a captive stock, these kind of phenotypically extreme characters can also be caused by random genetic drift.

The founders of the Hailuoto LWfG farm have been obtained from two Swedish farms, Öster-Malma and Eriksberg (Markkola et al. 1999). The pedigree information from the Hailuoto farm is incomplete and it was not possible to trace back the origin of all the mitochondrial lineages present in the captive stock. However, three of the 15 founders were included for the study (C25, C27, C28). One of them (C25) is a female with White-fronted Goose mtDNA, which suggests that also the Swedish stocks are contaminated with the alien alleles.

According to the international action plan for the conservation of the LWfG (Madsen 1996) reintroductions and restocking will be used to enhance the survival of the species and to increase or to maintain the size or genetic diversity of the wild population (sensu Kleiman et al. 1994). Since there are no indications of deleterious effects of inbreeding (e.g. offspring production in Fennoscandia comparable to other breeding areas; Aarvak et al. 1997) explaining the decline of the population there probably is no immediate need to carry out restocking efforts to increase the genetic diversity. More importantly, since the main causes for the species' decline, hunting and habitat destruction (Lorentsen et al. 1999), still threaten the wild population it is likely that the individuals with captive origin have lower chances for survival compared with wild individuals along the traditional migration route of the LWfG. Ultimately, because of the mixed genetic background, the captive stock available is not appropriate for restocking or reintroduction. Introduction of heterospecific alleles may jeopardize the still existing wild population and creating a hybrid population as a reintroduction attempt does not serve the conservation purposes. As long as the proportion of the alien nuclear alleles present in the captive stock is not known,

the mixing of the wild population and birds with a captive origin should be prevented.

4. Acknowledgements

Thanks are due to Juha Markkola and Pekka Nieminen for sampling the captive birds and discussions concerning the captive stock. I wish to thank also all the (numerous) people who have contributed in some way.

References

- Aarvak, T., Øien, I. J., Syroechkovski Jr., E. E. & Kostadinova, I. 1997: The Lesser White-fronted Goose Monitoring Programme. Annual report 1997.-Klæbu, Norwegian Ornithological Society. NOF Rapportserie. Report no. 5-1997.
- Delacour, J. 1954: The waterfowl of the world. Vol. 1. Country Life Ltd., London.
- von Essen, L. 1996: Reintroduction of LWfG (*Anser erythropus*) in Swedish Lapland (1981–1991). – *Gibier Faune Sauvage, Game Wildlife* 13:1169–1180.
- von Essen, L. 1999: The Swedish reintroduction project of Lesser White-fronted Geese. In: Tolvanen, P., Øien, I. J. & Ruokolainen, K. (eds.): Fennoscandian Lesser White-fronted Goose conservation project. Annual Report 1998. – WWF Finland Report 10 & Norwegian Ornithological Society, NOF Rapportserie Report no. 1-1999:47–50.
- Gray, A. P. 1958: Bird hybrids. A checklist with bibliography. Commonwealth Agricultural Bureaux, Bucks, England.
- Kleiman, D. G., Stanley Price, M. R. & Beck, B. B. 1994: Criteria for reintroductions. In: Olney, P. J. S., Mace, G. M. & Feistner, A. T. C. (eds.): Creative conservation: Interactive management of wild and captive animals. Chapman & Hall, London. Pp. 287–303.
- Lorentsen, S.-H., Øien, I. J., Aarvak, T., Markkola, J., von Essen, L., Faragó, S., Morozov, V., Syroechkovsky, E. Jr. & Tolvanen, P. 1999: Lesser White-fronted Goose *Anser erythropus*. In: Madsen, J., Cracknell, G. & Fox, T. (eds.): Goose populations of the Western Palearctic. A review of status and distribution.- Wetlands International Publ. No 48. Wetlands International, Wageningen, The Netherlands. National Environmental Research Institute, Rønde, Denmark. Pp. 144–161.
- Madsen, J. 1996 (compiler): Lesser White-fronted Goose. In Heredia, B., Rose, L. & Painter M. (eds.): Globally threatened birds in Europe. Action Plans. Council of Europe Publishing, Strasbourg, France.
- Markkola, J., Timonen, S. & Nieminen, P. 1999: The Finnish breeding and restocking project of the Lesser White-fronted Goose: results and the current situation in 1998. In: Tolvanen, P., Øien, I. J. & Ruokolainen, K. (eds.): Fennoscandian Lesser White-fronted Goose conservation project. Annual report 1998. – WWF Finland Report 10 & Norwegian Ornithological Society, NOF Rapportserie Report no. 1-1999. Pp. 47–50.
- Nagy, E. 1950: Über Gänsebastarde. In *Syllogomena Biologica, Festschr.* 80. Geburtst. Otto Kleinschmidt. Akademische Verlagsgesellschaft Geest & Portig, Leipzig. Pp. 256–266.
- Panov, E. N. 1989: Hybridization and ethological isolation in birds. Nauka, Moscow. (In Russian)
- Ruokonen, M., Kvist, L., Aarvak, T., Iwabuchi, S., Lei, G., Markkola, J., Morozov, V., Syroechkovsky, E. Jr., Tolvanen, P., Øien, I. J. & Lumme J. 2000a: Population genetic structure and phylogeography of the Lesser White-fronted Goose, manuscript.
- Ruokonen, M., Kvist, L. & Lumme J. 2000b: Close relatedness between mitochondrial DNA from seven *Anser* goose species. – *J. Evol. Biol.*, in press.
- Ruokonen, M., Kvist, L., Tegelström, H. & Lumme, J. 2000c: Goose hybrids, captive breeding and restocking of the Fennoscandian Lesser White-fronted Goose (*Anser erythropus*), submitted manuscript.
- Shackleton, K. 1956: Apparent hybrid Lesser White-fronted x White-fronted Goose in Hampshire and Sussex.-*British Birds* 49:229–230.
- Templeton, A. 1986: Coadaptation and outbreeding depression. In: Soule, M. (ed.): *Conservation Biology*. Sinauer Associates, Sunderland MA. Pp. 105–116.

SHORT NEWS

Lesser White-fronted Goose exhibition

In autumn 1999, the Finnish Lesser White-fronted Goose (*Anser erythropus*, later LWfG) Life Project arranged a large exhibition concerning LWfG, ranging from scientific research to conservation actions world wide. The exhibition, consisting of 13 large posters in English and Finnish was arranged in Inari in northern Finnish Lapland, in the Sami Museum *Siida* from 15 November, 1999 until 15 January, 2000.

The posters depicted identification of LWfG and the ecology of the species in the breeding grounds and at the migration staging places. A central subject was the different actions of the LWfG project. The spring migration route from Greece via Hungary, Estonia and the Finnish Bothnian Bay to breeding areas in Lapland and Finnmark was presented by an own poster, as well as the autumn migration route from Lapland and Finnmark via the Kanin

Peninsula and Kazakstan to wintering areas somewhere in the Caspian Sea – Black Sea region.

The breeding, from the egg-laying and incubation period to the fledging of goslings and a description of the breeding areas were presented as were also the monitoring work along the migrating routes and in the breeding areas. Other posters described catching of geese by cannon nets at a staging ground, catching of LWfG during moulting for ringing and satellite transmitter tagging, expeditions to Siberia, Kazakstan and China, farming of captive LWfG and genetic studies.

The posters, including c. 75 pictures, were supplemented by a set of 50 slides, a short video film, a recording of LWfG voices and examples of field equipment like satellite transmitters, colour rings and a cannon net.

The exhibition was visited by c. 3000 persons from altogether 26 different countries.

The exhibition (posters) is designed to

be transportable, and it will be circulated first in Finland and later also in other countries: contact Maarit Kyöstilä, Siida / Northern Lapland Visitor Centre, FIN-99870 Inari, Finland, e-mail: maarit.kyostila@metsa.fi

Internet pages based on the exhibition can be viewed at <http://www.metsa.fi/natural/projects/lwfg/index.htm> (in English) and at <http://www.metsa.fi/luo/projektit/kiljuh/index.htm> (in Finnish).

Jarmo Pääläinen
Sami Timonen

North Ostrobothnia Regional
Environment Centre, P.O. Box 124,
FIN-90101 Oulu, Finland,
e-mails: jarmo.paalainen@vyh.fi,
sami.timonen@vyh.fi

SHORT NEWS

Lesser White-fronted Goose exhibition

In autumn 1999, the Finnish Lesser White-fronted Goose (*Anser erythropus*, later LWfG) Life Project arranged a large exhibition concerning LWfG, ranging from scientific research to conservation actions world wide. The exhibition, consisting of 13 large posters in English and Finnish was arranged in Inari in northern Finnish Lapland, in the Sami Museum *Siida* from 15 November, 1999 until 15 January, 2000.

The posters depicted identification of LWfG and the ecology of the species in the breeding grounds and at the migration staging places. A central subject was the different actions of the LWfG project. The spring migration route from Greece via Hungary, Estonia and the Finnish Bothnian Bay to breeding areas in Lapland and Finnmark was presented by an own poster, as well as the autumn migration route from Lapland and Finnmark via the Kanin

Peninsula and Kazakstan to wintering areas somewhere in the Caspian Sea – Black Sea region.

The breeding, from the egg-laying and incubation period to the fledging of goslings and a description of the breeding areas were presented as were also the monitoring work along the migrating routes and in the breeding areas. Other posters described catching of geese by cannon nets at a staging ground, catching of LWfG during moulting for ringing and satellite transmitter tagging, expeditions to Siberia, Kazakstan and China, farming of captive LWfG and genetic studies.

The posters, including c. 75 pictures, were supplemented by a set of 50 slides, a short video film, a recording of LWfG voices and examples of field equipment like satellite transmitters, colour rings and a cannon net.

The exhibition was visited by c. 3000 persons from altogether 26 different countries.

The exhibition (posters) is designed to

be transportable, and it will be circulated first in Finland and later also in other countries: contact Maarit Kyöstilä, Siida / Northern Lapland Visitor Centre, FIN-99870 Inari, Finland, e-mail: maarit.kyostila@metsa.fi

Internet pages based on the exhibition can be viewed at <http://www.metsa.fi/natural/projects/lwfg/index.htm> (in English) and at <http://www.metsa.fi/luo/projektit/kiljuh/index.htm> (in Finnish).

Jarmo Päälainen
Sami Timonen

North Ostrobothnia Regional
Environment Centre, P.O. Box 124,
FIN-90101 Oulu, Finland,
e-mails: jarmo.paalainen@vyh.fi,
sami.timonen@vyh.fi

Lesser White-fronted Goose protected in Turkmenia

The State Committee for Environmental Protection of Russia organised a conference concerning the strategy of use and conservation of Russian wetlands in the period 24-26 February, 1999 in Moscow. During the conference, the protection of the Lesser White-fronted Goose (*Anser erythropus*, later LWfG) within the Russian Federation and also in other neighbouring countries was discussed between the nature conservation authorities and scientists. A Turkmenian scientist asked for contribution to compile an appeal to Turkmenian authorities concerning the protection of the LWfG in Turkmenia. According to him, LWfG was added to the Red Data Book of Turkmenia on 21 June, 1999. This is the first step in protection of the LWfG in Turkmenia.

Turkmenia has formerly been, and could possibly still be an important wintering ground for the LWfG. This was also indicated by the International Waterbird Census (IWC) last spring, when Eldar A. Rustamov observed 43 LWfG at Krasnovodsk Gulf (39°42'–40°02'N, 52°53'–53°32'E) in the period 15-18 March, 1999, and further 395 LWfG somewhat more east at Balkhan Gulf (39°49'–40°02'N, 53°32'–53°50'E) in the period 19–20 March, 1999.

Juha Markkola

New information about wintering Lesser White-fronted Geese in Uzbekistan

In spring 1999, a study titled "Review on Anatidae species and their key sites in Uzbekistan" was published in Uzbekistan by Kreuzberg-Mukhina et al. In this review, lesser White-fronted Goose (*Anser erythropus*, later LWfG) is said to be wintering and also regularly hunted in the Surkhandarya region, along the upper stretches of River Amudarya (37°14'N, 67°47' E), in the bordering areas between Uzbekistan and Afghanistan and close to the border of Tadjikistan. LWfG is proposed to be included in the Appendix of the Red Data Book of Threatened Animals of Uzbekistan (Asimov 1996) as a rare migrant for which hunting and trapping should be forbidden.

According to the review, the proportion of LWfG in hunting bags of geese during winter in the area indicate a rough estimate of 2000–4000 wintering LWfG. This incur that Uzbekistan could be one of the most

important wintering places for LWfG along the European-Siberian-Caspian flyway by now. However, one needs to keep in mind (as shown e.g. in Kazakstan; see Tolvanen et al. 2000, pp. 43–50 in this report) that the statistics of the hunting bags can be unreliable, as White-fronted Geese (*A. albifrons*) are commonly erroneously identified as LWfG.

Original text of the review (English slightly revised) is as follows:

"Lesser White-fronted Goose - Anser erythropus. Status: For this species there is only one reliable old finding known (April, 1944) in the lower parts of the Amudarya river. Data on migration and wintering is practically missing (Kashkarov 1987), but in Surkhandarya region (high parts of Amudarya, near Termez), flocks of LWfG are wintering regularly. In 1990, the proportion of LWfG in the hunting bag was evaluated to be c. 20-30%. The Lesser White-fronted Goose is present in c.20 % of goose flocks, mainly consisting of Greylag Geese (Anser anser). In Chardara water reservoir LWfG has been hunted occasionally during the last years. LWfG commonly occur in flocks of 8-10 birds (Nazarov unpubl.).

Conservation status: This species is suggested to be included in the Appendix of the Red Data Book of Threatened Animals of Uzbekistan (Asimov 1996) as rare migrant. Hunting and trapping should be forbidden".

References

- Asimov, D.A., Abdunazarov, B.B., Vashetko, E.V., Lanovenko, Ye.N., Zinoviev, S.A., Mukhina, E.A., Mirzaev, U.T., Khodjaev, A.F., Shernazarov, E.Sh. 1996: Rare and vanishing animal species of Uzbekistan. Informative bull. 27 pg. Tashkent, "FAN". (In Russian)
- Kashkarov, D. Yu. 1987: Order Anseriformes. In: Birds of Uzbekistan, V.1:57–123. Tashkent, "FAN". (In Russian)
- Kreuzberg-Mukhina E.A., Kashkarov, D. Yu., Lanovanko Ye., N., Nazarov, O.P., Elmurod, Sh. & Shernazarov, E.Sh. 1999: Review on Anatidae species and their key sites in Uzbekistan.
- Tolvanen, P., Eskelin, T., Aarvak, T., Eichhorn, G., Øien, I.J. & Gurtovaya, E. 2000: Monitoring the autumn staging of Lesser White-fronted Geese in Kazakstan, October 1999. In: Tolvanen, P., Øien, I.J. & Ruokolainen, K. (eds.): Fennoscandian Lesser White-fronted Goose Conservation Project. Annual report 1999. – WWF Finland Report 12 & Norwegian Ornithological Society, NOF Rapportserie report no. 1-2000:43–50.

Elena Kreuzberg-Mukhina & Juha Markkola

Status of the awareness campaign for the Lesser White-fronted Goose

Introduction

The awareness campaign for the Lesser White-fronted Goose (*Anser erythropus*, later LWfG) was implemented in the autumn 1998. The basic need is to increase the knowledge and raise awareness on the species' situation among management authorities, and especially, hunters in the countries hosting staging or wintering populations of the species (Kostadinova et al. 1999). The campaign was initiated by the Norwegian Ornithological Society (NOF) and the Bulgarian Society for the Protection of Birds (BSPB) has been responsible for the production of the information material on the ecology, occurrence and identification of LWfG (posters and stickers). This material was produced during 1998 and 1999 in order to be distributed in villages, among groups of hunters and in local/regional administration offices.

The aims of the campaign have been to: Raise awareness among hunters, and try to move the hunting pressure away from the LWfG to a sustainable hunting on the more numerous goose species, e.g. Greylag Goose (*A. anser*) and White-fronted Goose (*A. albifrons*).

Status of the Awareness campaign

The preparation work on the production of information material (poster/sticker) was carried out in 1998 and 1999. During 1999 altogether 11,740 posters and 23,800 stickers are produced in eight different languages/versions. The printed material describes the ecology, occurrence and identification of LWfG in the languages of seven key countries where the LWfG is threatened by hunting - Kazakstan, Azerbaijan, Ukraine, Bulgaria, Hungary, Romania and Russia. For Kazakstan, which possess spring and autumn gathering sites of major importance for both the Fennoscandian and the western Siberian populations of LWfG, both a Russian and a Kazak language version is produced. In addition, we made an English version of the information material for general information and international promotion of the LWfG conservation work.

The printed material is now distributed to the contact persons in all countries except for Azerbaijan (due to technical problems), but during the first part of 2000 the material will be sent to our contact in Azerbaijan. At present the material is being distributed among hunters and local



Photo. During the Lesser White-fronted Goose surveys in northern Kazakhstan, posters and stickers were distributed widely among hunters and general public in October 1999; here is the Kazakh language version of the sticker. © Petteri Tolvanen, 1999

people in key staging areas as well as in the breeding areas in Russia. In Bulgaria, the material was already spread in all areas where LWfG occur in June 1999, and the posters was exposed in visiting places for Eco-tourists as well as in villages in north-east Bulgaria where the hunting pressure on geese is high.

In Kazakhstan, the material was spread during October 1999. This was carried out in close co-operation with the Naurzum State Nature Reserve in the Kustanay area, and the Kurgaldshinski State Nature Reserve in the Astana area. Meetings were held with the national management authorities in Astana. Parallel with the distribution of the material, a comprehensive survey of the occurrence of LWfG was carried out in the Lake Tengiz and the Kustanay area (see Tolvanen et al. 2000, pp 43–50 in this report). Data on the species and age ratios of mixed goose flocks, distribution, behaviour and area use of LWfG in these areas was carried out in order to provide basic knowledge to the management authorities for future conservation efforts. According to the progress plan, the awareness project is fulfilled. However, further national distribution and practical use of the material in the conservation work for LWfG will continue in the future.

In near future the awareness campaign should be extended to the main wintering areas in China, the East Dongting Lake area. The importance of this area for the world population of LWfG, and the poisoning of

LWfG even in the core area of the Nature Reserve (see Markkola et al. 2000, pp 9–15 in this report), makes it the highest priority target area for the awareness campaign.

References

- Kostadinova, I., Øien, I.J. & Aarvak, T. 1999:** Awareness campaign for the Lesser White-fronted Goose. In Tolvanen, P., Øien, I.J. & Ruokolainen, K. (eds.): Fennoscandian Lesser White-fronted Goose conservation project. Annual report 1998. – WWF Finland Report 10 & Norwegian Ornithological Society, NOF Rapportserie Report no. 1-1999:11.
- Markkola, J., Iwabuchi, S., Lei Gang, Aarvak, T., Tolvanen, P. & Øien, I.J. 2000:** Lesser White-Fronted Goose survey at East Dongting and Poyang Lakes in China, February 1999. In: Tolvanen, P., Øien, I.J. & Ruokolainen, K. (eds.): Fennoscandian Lesser White-fronted Goose Conservation Project. Annual report 1999. – WWF Finland Report 12 & Norwegian Ornithological Society, NOF Rapportserie Report no. 1-2000: 9-15.
- Tolvanen, Eskelin, Aarvak, Eichhorn, Øien & Gurtovaya 2000a:** Monitoring the autumn staging of Lesser White-fronted Geese in Kazakhstan, October 1999. In: Tolvanen, P., Øien, I.J. & Ruokolainen, K. (eds.): Fennoscandian Lesser White-fronted Goose Conservation Project. Annual report 1999. – WWF

Finland Report 12 & Norwegian Ornithological Society, NOF Rapportserie Report no. 1-2000:43–50.

Ingar Jostein Øien, Irina Kostadinova & Tomas Aarvak

New Lesser White-Fronted Goose data from Lithuania

A questionnaire about the situation for the Lesser White-fronted Goose (*Anser erythropus*, later LWfG) together with some basic information about the species has been sent to countries along the migration routes of the LWfG by the Finnish LWfG Life project. The target organisations are ministries responsible for nature conservation and hunting as well as governmental and non-governmental hunting and conservation organisations in Estonia, Latvia, Lithuania, Belarus, Ukraine, Moldova, Romania, Bulgaria, Turkey, Poland, Germany, Czech Republic, Slovak Republic, Hungary, Slovenia, Bosnia-Herzegovina, Croatia, Yugoslavia, Albania, Georgia, Armenia, Azerbaijan, Iran, Iraq, Turkmenistan and Uzbekistan. Also Russia, Kazakhstan and Greece will be contacted, but in a different way, because these countries are already involved in international conservation efforts for the LWfG and have some own national conservation initiatives.

One of the most interesting answers to the questionnaire was received from Lithuania. At present, after the protection of LWfG in Romania, Lithuania is the only country in Europe, where the LWfG is not officially protected.

LWfG protected by 2001?

Surprisingly, the Red Data Book of Lithuania contains only rare and endangered animal, plant and fungi species that grow and reproduce within the territory of Lithuania. The species registered only on migration, as is the case of LWfG, are not included in the Red Data Book. On the other hand, LWfG is neither included in the list of wild animal species that are allowed to be exploited (including hunting, catching) in Lithuania (Order of the Minister of Environment No. 249, approved 11 December, 1998). However, this does not have any effect, because there is no penalty foreseen for killed LWfG. On the list of penalties for illegally killed animals (Resolution of the Government of the Rep. of Lithuania No. 1276, 19 December, 1994) only the following text is included: "wild geese (Bean or White-

fronted), the Barnacle Goose – penalty 70 LT" (1 LT=c.0.25 USD). This matter is administered by Biodiversity Division and Nature Resources Division of Nature Protection Department in the Ministry of Environment.

Luckily, the situation will probably change quite soon, because Lithuania is a candidate member of the EU and will carry into effect the EU Birds Directive, where the LWfG is included in Annex I of strictly protected species. An approximation project on EU Habitats and Birds Directives in Lithuania started in September 1999 and will be completed by 2001.

Updated information about the occurrence of the LWfG in Lithuania

The Nature Resources Division of the Ministry of Environment possess statistics only on shot wild geese in general, without separating different species. Ms. J. Urbelionyte from the Nature Resources Division provided statistics of shot geese, except the species included in the Red Data Book. The hunting bag was not very big, 222 geese during the hunting period 1 October – 1 December, 1997 and 60 geese in the period 1 October – 1 December, 1998.

A summary of the occurrence of the LWfG in Lithuania was presented in 1996 by Svazas (1996). A more updated and more comprehensive article was published by Svazas et al. (1997). In these articles, the authors concluded that the staging areas of the LWfG are insufficiently investigated and that LWfG are probably frequently overlooked in large flocks of other goose species. However, until the 1960's, large flocks were sometimes observed: e.g. flocks up to 600–800 LWfG in coastal areas, especially at Kurshiu Lagoon and Nemunas River Delta (55°18'N, 21°20'E) (Valkevicius 1967 cited in Svazas 1996).

According to Svazas et al. (1997), LWfG has been characterised as a very rare and irregular migrant in most published articles, with only single birds or small flocks recorded (Ivanauskas 1959 and Valius 1980 according to Svazas et al. 1997, Logminas 1990). Recent findings, however, indicate that LWfG is still an uncommon, but rather frequent migrant in western Lithuania and also inland observations exist.

LWfG flocks have been frequently recorded during recent intensive autumn surveys (Svazas et al. 1997), but only single birds in spring. A flock of 130 staging LWfG was observed in the Nemunas river delta area in late September 1989. In autumn 1992 (late September - early October), 76 staging LWfG stayed in flooded grasslands east of the delta area

and 43 birds were recorded on pastures near the town of Silute E of the delta area. The largest flock of staging LWfG (200–230 birds) was recorded in the Nemunas Delta area in early October 1995, and a flock of 43 LWfG stayed in wet pastures near Silute in late September 1995 (Svazas 1996). Small staging flocks (up to 30 birds) were also recorded in several coastal sites in autumn 1996–1997.

For the inland areas, Mr. V.Nedzinskas (cited in Logminas 1990) mentions that single birds or small staging groups of LWfG were almost annually recorded in Zuvintas Lake strict nature reserve in 1966–1986, but other ornithologists e.g. Mr. A. Pranaitis have stated that there are no reliable records of LWfG in southern Lithuania for the last 15 years. However, several single birds or small groups of LWfG have been recorded in certain inland sites during recent years. Larger flocks (up to 107 birds) were observed in the Raseiniai district in autumn 1994 and 1997 (Svazas et al. 1997). A single bird stayed 17–19 May, 1985 at the fish ponds in Kietaviskes, Kaisiadorys district (Preiksa & Raudonikis 1998). Furthermore, a flock of 22 birds was seen in Kauno Marios reservoir, Kaunas district on 2 April, 1997 (Preiksa & Raudonikis 1998).

There are only two real wintering observations of the LWfG in Lithuania: in January–February 1980 one young individual wintered in Vilnius town in a pond (Preiksa & Raudonikis 1998), and one wintering bird was observed in 1982 (Idzelis & Grazulevicius 1987 cited in Svazas 1996).

Conservation status of LWfG staging places in Lithuania and suggestions to intensify protection

According to Svazas et al. (1997), several Lithuanian LWfG staging sites are located in protected territories: Zuvintas strict nature reserve (cf. comment above), Nemunas Delta Regional Park. However, the most important staging areas in Silute and Raseiniai districts are not protected and are threatened by possible change of these habitats into agricultural land.

The list of needed activities for conservation of the LWfG in Lithuania is quite long, but well argued:

1. include the LWfG in the Red Data Book of Lithuania
2. improve public awareness especially among hunters (identification of LWfG among White-fronted Geese)
3. set high penalties for killed LWfG
4. to prohibit goose hunting in September–October in the goose staging areas located in Nemunas Delta Regional Park and other important areas near Silute town and in the Raseiniai district

5. carry out supplementary surveys at important or potential staging sites of the LWfG
6. restrict human exploitation of the staging areas near Silute town and Raseiniai district
7. carry out habitat management in order to avoid overgrowing with shrubs and trees

It is obvious that at least a part of the observed LWfG belong to the Fennoscandian breeding population and visit Lithuania on their way to Hungary and Greece (see Lorentsen et al. 1998) and back. Implementation of LWfG protection in Lithuania is of the highest importance.

References

- Logminas, V. (ed.) 1990:** Lithuanian fauna. Birds Vol. 1:79–81. (In Lithuanian)
- Lorentsen, S.-H., Øien, I. J. and Aarvak, T. 1998:** Migration of Fennoscandian Lesser White-fronted Geese *Anser erythropus* mapped by satellite telemetry. – *Biological Conservation* 84:47–52.
- Preiksa, Z. & Raudonikis, L. 1998:** Report of the Lithuanian ornithofaunistic commission. – *Ciconia* 6:64. (In Lithuanian)
- Svazas, S. 1996:** The Lesser White-fronted Goose in Lithuania. – *Wetlands international Goose Specialist Group Bulletin* 7, April 1996:8–9.
- Svazas, S., Stanevicius, V. & Cepulis, M. 1997:** Status, numbers and distribution of swans and geese in Lithuania. – *Acta Zoologica Lituanaica, Ornithologia*, vol.6.
- Valkevicius 1967:** Bird migration in the Kurshiu Lagoon areas in 1962–1966 (In Russian). – *Procl. Inst. Zool.*, Vilnius: 15–37.

Darius Stoncius & Juha Markkola



Photo. A pair of Lesser White-fronted Geese at the Valdak Marshes, Norway. © Ingar Jostein Øien, May 1999

SHORT NEWS

Observations of Lesser White-fronted Geese in central Europe in autumn 1999

During goose surveys at well known staging places for geese in Hungary, Austria and eastern Germany in October and November 1999, Lesser White-fronted Geese (*Anser erythropus*, later LWfG) were observed at seven different sites. In Hungary, the fish ponds in Hortobagy and Biharugra are well known as stopover sites for the Fennoscandian wild population of LWfG. Also the birds observed in eastern Germany and Austria most probably belong to the Fennoscandian

Table 1. Observations of Lesser White-fronted Geese in Central Europe in autumn 1999.

Date	Locality	Country	Number	Comment
26 Oct	Soponya Fishponds	Hungary	2 ad	unringed
27 Oct	Halastó, Hortobagy	Hungary	36	flying to roost
29 Oct	Biharugra Fishponds	Hungary	16	leaving roost
30 Oct	Sükösd, Gemerc	Hungary	2 ad	unringed
7-8 Nov	Larye Lake (Neusiedler See)	Austria	6	at the roost
14 Nov	Schwedt/Oder	Germany	1 ad	at feeding area
18-19 Nov	Neolitheid, Köthen	Germany (Sachsen Anhalt)	28	at the roost

unmanipulated population. It is interesting to notice that 28 LWfG were observed in eastern Germany in mid-November, when 36 LWfG had been observed further south in Hungary already three weeks before. This may indicate that the Fennoscandian LWfG migrate in several bouts on the central European migration route, and even though the LWfG gosling production in Fennoscandia seemed to be low in 1999, the number of LWfG using this route was

quite high (at least if, as assumed, the birds at Biharugra and Hortobagy were not the same birds). Altogether at least 84 individuals were observed.

Leo van den Bergh
Alterra, Wageningen,
The Netherlands

New wintering area for Lesser White-fronted Geese in Crimea Peninsula, Ukraine

Lesser White-fronted Goose (*Anser erythropus*, later LWfG) is not previously described as a wintering species in Crimea. In recent years a marked increase in the number of geese wintering in the Crimea Peninsula has been observed. Among the common goose species, which numbers several hundred thousand individuals, LWfG have been observed in total numbers up to 1000 individuals. Some of the LWfG have been observed mixed in flocks of Red-breasted Geese (*Branta ruficollis*). In these new wintering grounds for geese, several circumstances are unfavourable. The economical situation for local people is aggravating, which incur an unregulated hunting on the geese, including LWfG. There is reason to be worried about the situation for the wintering geese in this area in general, because the goose flocks are now intensively hunted. The situation for LWfG is especially worrying, as local people have no knowledge about the critical conservation status of the species. Since wintering of geese is a new phenomenon in Crimea, no management traditions exist that might regulate hunting. The need for implementing conservation measures are therefore urgent in this area.

Alexander V. Kondratyev
& Valery A. Buzun
Biological Institute of the St.Petersburg
State University

Alexander Grinchenko, Azovo-Sivash
Ornithological Station, Lenina str. 20,
Melitopol, 332339, Zaporozhskaya region,
Ukraine



Photo. A pair of Lesser White-fronted Geese at the Valdak Marshes, northern Norway in May 1999. It is unknown whether the Fennoscandian LWfG migrate through Ukraine or not. © Ingar Jostein Øien, May 1999

Co-operation partners and contacts

BirdLife International

Colin Bibby

EU Commission

Seppo Vuolanto

Wetlands International

Bart S. Ebbinge

WWF Arctic Programme

Peter Prokosch

Belarus

Institute of Zoology, Belarus Academy of Science

Alexey K. Tishechkin

Bulgaria

Bulgarian Society for the Protection of Birds (BSPB)

Petar Iankov, Irina Kostadinova, Dimitar Georgiev, Sergey Deleriev

The Peoples Republic of China

Board of Forestry, Province of Hu Nan, China

Eastern Dongting Lake Strict Nature Reserve

Poyang Lake Strict Nature Reserve

Shanghai Normal University

Gui Xiao-jie

Jian Yong, Lei Gang, Song Fazhong

Mr. Zhao, Mr. Yi

Jianjian Lu, He Wenshem

Croatia

Dept. of Nature Conservation, Ministry of Civil engineering and Nature
Institute of Ornithology

Jasminca Radovic

Jelena Kralj

Czech Republic

Jihocesce Muzeum

Institute of Agriculture and Natural Sciences

Czech Ornithological Society

Peter Burgur

Marcel Honza

Jan Hora

Estonia

Matsalu Nature Reserve

Estonian Ornithological Society

Maire Toming, Alex Lotman, Tiit Kaljuste, Taivo Kastepõld

Aivar Leito

Finland

Bongariliitto / Lintutiedotus, Finland

Employment Offices in Finland

Finnature

Finnish Ministry of the Environment

Finnish Museum of Natural History, Ringing Centre

Inarin riistanhoitoyhdistys

Pohjois-Pohjanmaan lintutieteellinen yhdistys

Pori Environmental Institute, Univ. of Turku

Frontier Guard of Finland

University of Oulu (Finland), Department of Biology

Jari Peltomäki, Ulla Peltomäki

Pertti Rassi, Matti Osara, Esko Jaakkola, Jussi Soramäki

Pertti Saurola

Jaakko Lumme, Marika Niemelä, Minna Ruokonen

Germany

Galenbecker Ornithological Station

Max-Planck-Institute of Colloid and Interface Research

Biological Station Wesel

Naturschutzbund Deutschland (NABU)

Stefan Krüger

Edwin Donath

Johan Mooij

Götz Eichhorn

Greece

WWF Greece

Hellenic Ornithological Society

Society for protection of Nature and Ecodevelopment

Hellenic Republic ministry of Agriculture

Stella Kladara, Panagiota Maragou, Kostas Pistolas

Theodoros Naziridiz

Hans Jerrentrup

G.I. Handrinos

Hungary

Hungarian Nature Conservation Authority

Hortobagy National Park

MME/BirdLife Hungary

Hungarian Nature Conservation Authority

Zsolte Kalota's

Gabor Kova'cs, Janos Tar

György Szimuly

Gabor Magyor

Japan

Japan Association for wild Geese Protection, Sendai Science Museum

Japanese Association for Wild Geese Protection

Shigeki Iwabuchi

Masayuki Kurechi

Kazakstan

Ministry of agriculture

Environmental Agency of Akmola Region

E. Mejramov

APPENDIX A

Institute of Zoology, Academy of Sciences
The Forest, Fish and Hunting Inspection Committee of
the Kustanay Region
Naurzum National Reserve
Kurgadzhinskiy Zapovednik

Amankul Bekenov, Sergey Yerohov
Valeri Poddubny

Tatyana Bragina, Evgeny Bragin
Murat Aytjanov

Latvia

Latvian Ornithological Society

Edmunds Razinskis

Lithuania

Institutas Ecologijias
Ventes Ragas Ornithological Station
Lietuvos Gamtos Fondas

Gedas Vaitkus
Vytautas Jusys
Darius Stoncius

Norway

Directorate for Nature Management
Country Governor of Finnmark, Environm. Dept.
Porsanger municipality
Norwegian Institute for Nature Research
Statskog Finnmark – Mountain Service
Stabburnes Nature house & Museum
Statens naturoppsyn (SNO) (State Nature Control)

Morten Ekker, Arild R. Espelien
Eirik J. Karlssen
Kristina Bjørkli
Svein-Håkon Lorentsen
Torkjell Morseth
Barb L. Håland
Jostein Sandvik

Poland

Institute of Zoology, Polish Academy of Sciences
Institute of natural history, Wroclaw University
Gdansk Ornithological Station

Jerzy Dyczkowski
Jan Lontkowski
Przemek Chylarecki

Romania

Romanian Ornithological Society, Tulcea Office
Romanian Ornithological Society
Danube Delta Institute

Eugen Petrescu
Dan Munteanu
Janos Bottond-Kiss

Russia

Hinganskij Nature Reserve (Amur oblast)
Russian Academy of Science
Academy of Science of Karelian State
Finnish-Russian Nature Conservation Committee
Bird Ringing Centre, Russian Academy of Science
Carelian Scientific Centre, Russian Academy of sciences
Institute for Ecology & Evolution, Russian Academy of Science
Russian State Committee for Environmental protection,
Department of Biological Resources
State Committee of Environment Protection, Russian Institute
for Nature Conservation
Russian Bird Conservation Union (RBCU)
WWF Russian Programme Office

Mihail Parilov

Elena Gurtovaya, Konstantin E. Litvin

Eugeny E. Syroechkovski Jr.
Valentin Ilyashenko

Vladimir V. Morozov

Elena Lebedeva
Victor Nikiforov

Slovenia

Bird watching and Bird study Association of Slovenia.

Peter Trantelj

Slovakia

Slovakian Ornithological Society

Pavol Kanuch

Sweden

Tovetorp Zoologiska forskningstation
Swedish Hunters Society
WWF Sweden
Swedish Ornithological Society (SOF)

Anders Bylin
Lambart von Essen
Ola Jennersten
Björn Welander

Lesser White-fronted working group of WWF Finland in 1999

Aikio Esko, Alhainen Jouko, Arkiomaa Aki (chairman of the group), Alho Pentti, Haapala Seppo, Herva Elja, Holmström Heikki, Eskelin Toni, Kalinainen Pertti, Karlin Antti, Karvonen Risto, Kellomäki Erkki, Koistinen Matti, Lampila Petri, Lavinto Ari, Lehmus Ilkka, Leinonen Ari, Leppäniemi Pirjo, Markkola Juha, Mela Matti, Merilä Eino, Niemelä Marika, Nieminen Pekka, Ohtonen Arvo, Pessa Jorma, Polojärvi Petteri, Pynnönen Jyrki, Pynnönen Petro, Pääläinen Jarmo, Rassi Pertti, Ruokolainen Kalle, Ruokonen Minna, Seppänen Sirpa, Toivanen Juhani, Timonen Sami, Tolvanen Petteri (secretary of the group) and Vikberg Pentti.

Partners of the LWfG Life project in Finland in 1999

Forest and Park Service, Northern Lapland District for Wilderness Management, Nature Conservation: Pirjo Leppäniemi, Kari Kyrö, Joska Laine, Petteri Polojärvi, Maiju Pasanen, Elina Stolt and Eero Sujala; Forest and Park Service, Nature Conservation: Lassi Karivalo; Häme Regional Environment Centre: Erkki Kellomäki and Natalia Ripatti; North Ostrobothnia Regional Environment Centre: Juha Markkola, Tupuna Kovanen, Jorma Pessa, Jarmo Pääläinen, Seppo Haapala, Ari Leinonen and Sami Timonen; Lapland Regional Environment Centre: WWF Finland: Jari Luukkonen, Marja Innanen, Tuuli Äikäs, Sirpa Pellinen and Petteri Tolvanen; Hunters' Central Organisation MKU: Pentti Vikberg; Volunteers in the project in 1999: Janne Aalto, Pirkaa Aalto, Riikka Kaartinen, Olli Koskinen, Aappo Luukkonen, Birgit Petrow, Arto Toivanen and Juhani Toivanen.

Publications from the Fennoscandian Lesser White-fronted Goose conservation project in the report period

Printed papers

- Anonymous 1999: The status of Lesser White-fronted goose in Europe and beyond. The Fennoscandian Lesser White-fronted Goose Conservation project. *Birding World* 12:242–246.
- Anonymous 1999: Lesser White-fronted Goose. In: *Biological Diversity in the Barents Region. The Barents Euro-Arctic Region. Brochure* 16 pp. BirdLife International 1998: Update on satellite tracking of Lesser White-fronted Geese. *BirdLife in Europe* 3 no.4:2.
- Gurtovaya, E., Tolvanen, P., Eskelin, T., Øien, I.J., Bragina, T., Aarvak, T., Eichhorn, G., Arkiomaa, A., & Timonen, S. 1999: Preliminary results of the Lesser White-fronted Goose monitoring in Kazakhstan in October 1999. *Casarca* (Bulletin of the Goose and Swan Study Group of Eastern Europe and North Asia) 5:145–154.
- Lorentsen, S.-H., Øien, I.J., Aarvak, T., Markkola, J., von Essen, L., Faragò, S., Morozov, V. V., Syroechkovski Jr., E. E. & Tolvanen, P. 1999: Lesser White-fronted Goose *Anser erythropus*. Pp. 144–161 in: Madsen, J., Cracknell, G. & Fox, T. (eds.): *Goose populations of the Western Palearctic. – a review of status and distribution.*
- Markkola, J. 1999: Progress in the Finnish conservation project for the Lesser White-fronted Goose in 1998. *Wetlands International Goose Specialist Group. 4th Annual meeting. January 24–28, 1999. Matsushima, Miyagi, Japan. Abstracts:* 11–14.
- Markkola, J., Bianki, V. & Zimin, V. 1998: The Lesser White-fronted Goose (*Anser erythropus*). In: Kotiranta, H., Uotila, P. Sulkava, S. & Peltonen, S.-L. (eds.): *Red Data Book of East Fennoscandia. – Ministry of the Environment, Finnish Environment Institute & Finnish Museum of Natural History. Helsinki.* Pp. 220–224.
- Markkola, J. & Merilä, E. 1998: Hailuodon Ison Matalan - Härkäsäikän luonnonsuojelualan käyttö- ja hoitosuunnitelmaehdotus. (Summary: The preliminary management plan for the Life-Nature protected area of Iso Matala - Härkäsäikkä). *Conservation of Liminganlahti Wetland.* 194 pgs + 11 appendices. Oulu. (concerning the LWfG pgs 110-118). (in Finnish)
- Markkola, J., Stolt, E., Timonen, S., Kovanen, T., Leppäniemi, P., Pääläinen, J., Ripatti, N. & Tolvanen, P. 1999: Conservation of the Lesser White-fronted Goose (*Anser erythropus*) population in Finland (1999). *Interim Report Contract no. : B4-3200/97/296 Metsähallitus - The Forest and Park Service. Ivalo 13.11.1997. Part 1 Cost report, part 2 Project activity report 34 pgs + 24 appendices.*
- Øien, I.J., Tolvanen, P., Aarvak, T. & Markkola, J. 1999: Occurrence and identification of Lesser White-fronted Goose. *Alula* 5:18-23.
- Øien, I.J. & Aarvak, T. 1999: Soloppgang i østen – også for dverggåsa? *Vår Fuglefauna* 22:58–59. (In Norwegian)
- Pessa, J. & Anttila, I. 1998: Liminganlahden ja Ison Matalan - Maasyvänlahden kestävän käytön yleissuunnitelma. *Alueelliset ympäristöjulkaisut* 90. Pohjois-Pohjanmaan ympäristökeskus. 82 pgs. (In Finnish)
- Timonen S., Markkola, J., Tolvanen, P., Karvonen, R., Lumme, J., Ruokonen, M., Pääläinen J. & Lampila, P. 1999: Kiljuhanhen suojelu 1997-1998: Perämeren rannoilta Kiinan talvehtimisjärville. - *Linnut-vuosikirja 1998.* pgs 10–22. (In Finnish)
- Tolvanen, P. 1999: Surveys of the Lesser White-fronted Goose and Red-breasted Goose in NW Kazahstan (1996)-1998” *Wetlands International Goose Specialist Group. 4th Annual meeting. January 24–28, 1999. Matsushima, Miyagi, Japan. Abstracts:* 11–14.
- Tolvanen, P. 1999: Ensimmäinen yhteispohjoismainen kiljuhanhiraportti julkaistiin. – *Tiira* 2/1999:5. (In Finnish)
- Tolvanen, P., Øien, I. J., Litvin, K., Aarvak, T. & Markkola, J. 1998: New data on migration of Lesser White-fronted Goose from Taymyr Peninsula. – *Casarca* 4:193–196.
- Tolvanen, P. & Øien, I.J. 1998: Satellites track the Lesser White-fronted Goose. Revealing the secret wintering grounds. – *WWF Arctic Bulletin* 4/1998: 15.
- Tolvanen, P., Øien, I.J. & Ruokolainen, K. (eds.) 1999: *Fennoscandian Lesser White-fronted Goose Conservation Project. Annual report 1998. – WWF Finland Report 10 & Norwegian Ornithological Society, NOF Rapportserie Report no. 1-1999.*
Including the articles: Monitoring and catching of staging Lesser White-fronted Geese at the Valdak Marshes in 1998. – New record of Lesser White-fronted Geese with brood in southern parts of Norway. – Two pieces of the spring migration puzzle of the Fennoscandian Lesser White-fronted goose population in place. – The Swedish reintroduction project of Lesser White-fronted Geese. – Awareness campaign for the Lesser White-fronted Goose. – The Finnish breeding and restocking project of the Lesser White-fronted Goose: results and the current situation in 1998. – Occurrence of Lesser White-fronted Geese in north-east Bulgaria in February 1998. – Surveys of Lesser White-fronted Geese and other geese in Olonets and Sivricha regions, Western Russia in spring 1998. – Field work in Lapland in 1998. – Monitoring Lesser White-fronted Geese in the Varangerfjord area in 1998. – Phylogeography and population genetic structure of the Lesser White-fronted Goose. – The spring migration of the Lesser White-fronted Goose at Bothnian Bay in 1998. – The management plan for the coastal meadows of Säärenperä. – A spring staging area for the Lesser White-fronted Geese recovered in Matsalu, Estonia. – Monitoring the autumn staging of Lesser White-fronted Geese in north-western Kazakhstan, October 1998. – Monitoring instructions for Lesser White-fronted goose surveys. – Southern population of Lesser White-fronted goose finally extinct in Norway? – Surveys and catching of Lesser White-fronted Geese at Taimyr Peninsula 1998: preliminary results on autumn migration routes mapped by satellite telemetry.

Inside field reports

- Aalto P., Aalto J. & Luukkonen A. 1999: Kiljuhanhi-inventoinnit. Enontekiöllä Pöyrisjärven erämaa-alueella 12.-27.6.1999. 13 pgs + 5 maps. Kiljuhanhi-Life-Projekti. Metsähallitus, Ylä-Lappi ja WWF-Finland.
- Kaartinen R. 1999: Ydinalueen inventoinnit 12.6-21.6-1999. 4 pgs, 4 maps. Kiljuhanhi-Life-Projekti.
- Karvonen R. 1999: Lesser White-fronted Goose monitoring and catching attempts at the Valdak marshes, Northern Norway, 15.8.-6.9.1999. 3 pgs, 1 map. Kiljuhanhi-Life-Projekti, WWF-Finland.
- Karvonen R., Leinonen A. 1999: Matkaraportti kiljuhanhi-inventoinneista 20.-31.7.-99. 5 pgs, 5 maps. Kiljuhanhi-Life-Projekti, Pohjois-Pohjanmaan ympäristökeskus, WWF-Finland.
- Karvonen R., Leinonen A & Koistinen M. 1999: Kiljuhanhi-inventoinneista ”ydinalueen” suunnalla sekä Jäämeren rantaniityillä kesäkuussa 1999. *Apnr.* 14 pgs 10 maps. Kiljuhanhi-Life-Projekti, Pohjois-Pohjanmaan ympäristökeskus ja WWF-Finland.
- Pasanen M., Alava M & Kitti P. 1999: Kiljuhanhien muuttoreittien havainnointi Ylä-Lapissa ja Pohjois-Norjassa 17.-30.5.1999. 12 pgs, 3 maps. Kiljuhanhi-Life-Projekti ja Metsähallitus, Ylä-Lappi.
- Polojärvi P., Mela M., Tynys T & Väilitalo M. 1999: Naalinpesien tarkastus ja ketunpyynti ydinalueella 3.-16.2.-99. 11 pgs. Naali-Life-Projekti, Kiljuhanhi-Life-Projekti, Metsähallitus, Ylä-Lappi.
- Polojärvi P. 1999: Kiljuhanhiretki ydinalueelle 20.5.-2.6.-99. 12 pgs, 2 maps. Kiljuhanhi-Life-Projekti, Metsähallitus, Ylä-Lappi.
- Polojärvi P. 1999: Kiljuhanhiretki ydinalueelle 12.-22.6.-99. 10 pgs, 4 maps. Kiljuhanhi-Life-Projekti, Metsähallitus, Ylä-Lappi.
- Polojärvi P., Kitti P. 1999: Retki Näätäjäjokivarteen 29.6.-2.7.-99. 3pgs, 4 maps. Kiljuhanhi-Life-Projekti, Metsähallitus, Ylä-Lappi.
- Polojärvi P., Kitti P. 1999: Retki Sevetijärven suunnalle 6.-9.7.-99. 3 pgs, 3 maps. Kiljuhanhi-Life-Projekti, Metsähallitus, Ylä-Lappi.
- Polojärvi P., Kitti P. 1999: Retki Kaldoaiviin 13.-22.7.-99. 8 pgs, 5 maps. Kiljuhanhi-Life-Projekti, Metsähallitus, Ylä-Lappi.
- Polojärvi P., Kitti P. 1999: Retki Paistunturin erämaan pohjoisosaan 3.-7.8.-99. 3 pgs, 1 map. Kiljuhanhi-Life-Projekti, Metsähallitus, Ylä-Lappi.
- Pääläinen J., Ruokonen M. 1999: Kiljuhanhi-inventointi Vätsärin itä-puolella ja Kevolla. 3 pgs, 4 maps. Kiljuhanhi-Life-Projekti, Pohjois-Pohjanmaan ympäristökeskus, WWF-Finland.

APPENDIX C

Annotated checklist of bird observations during the Lesser White-fronted Goose surveys in Kazakhstan, October 1999

Toni Eskelin & Petteri Tolvanen

This checklist is a summary of the bird observations made during the two parallel surveys in northern parts of Kazakhstan in October 1999; during the period 1–13 October in the Kustanay area, and 2–13 October in the Kurgaldzhino–Tengiz area. For goose species, see article on pp. 39–46.

Abbreviations

ind. = individual(s)
cy = calendar-year
ad = adult = "
juv = juvenile = '
x = 1–9 ind. xx= 10–99 ind.,
xxx= 100–999 ind. etc.
+= observed

Observers

Kustanay region: Toni Eskelin, Sami Timonen, Aki Arkiomaa, Tatyana Bragina and Evgeny Bragin. – Kurgaldzhino–Tengiz region: Petteri Tolvanen, Tomas Aarvak, Ingar Jostein Øien, Götz Eichhorn and Elena Gurtovaya.

For typical wetland birds

(*Podiceps cristatus* – *Oxyura leucocephala* and *Fulica atra*) see Table 1 and Table 2.

Phoenicopterus ruber

Tengiz: 12 October: 1 ind. with broken leg at Lake Zhumai

Haliaeetus albicilla

Kustanay: 14 ind.
Tengiz: 27 ind.

Circus aeruginosus

Kustanay: 1–3 October: a maximum of 10 ind. at Lake Kulykol, 6 October: 1 ind. at Lake Batpakkol
Tengiz: 7 ind.

Circus cyaneus

Kustanay: c. 60 ind.
Tengiz: c. 100 ind.

Circus macrourus

Kustanay: altogether 18 ind., of which the majority were ad males
Tengiz: c. 30 ind. of which the majority were ad males

Circus macrourus/pygargus

Kustanay: 1 October: 1 juv at Lake Kulykol
Tengiz: 4 female/juv. plumage

Accipiter nisus

Kustanay: 6 ind.
Tengiz: 8 ind.

Accipiter gentilis

Tengiz: 3 ind.

Buteo rufinus

Kustanay: 3 October: 1 ind. between lakes Kulykol – Ayke, 10 October: 1 ind. at Lake Tyuntyugur
Tengiz: c. 150 ind.

Buteo buteo

Tengiz: 1 ind. of race *vulpinus*

Buteo lagopus

Kustanay: 4 October: 1 ind. at Lake Ayke, 11 October: 3 ind. at Lake Tyuntyugur and 12 October: 5 ind at Lake Bozshakol
Tengiz: c. 10 ind.

Aquila heliaca

Kustanay: 6 October: 1 3cy+ at Lake Batpakkol, 7 October: 6 ad at Naurzum and 9 October: 1 2cy at Lake Kushmurun
Tengiz: 1 1cy near Karazhar, 9 October

Aquila nipalensis

Tengiz: >40 ind.

Aquila chrysaetos

Kustanay: 4 October: 1 2cy at Lake Ayke and 9 October: 1 2cy at Lake Kushmurun

Falco tinnunculus

Kustanay: 3 October: 1 ind. at Lake Kulykol, 4 October: 1 ind. at Lake Ayke and 7 October: 2 ind. at Naurzum forest
Tengiz: some tens

Falco columbarius

Kustanay: 19 ind.
Tengiz: c. 30 ind., mostly of race *pallidus*

Falco peregrinus

Kustanay: 1 juv at Lake Kulykol, 1 October
Tengiz: 1 1cy in Karazhar, 5 October

Falco subbuteo

Tengiz: 3 ind.

Tetrao tetrix

Kustanay: 7 October: c. 85 ind. at Naurzum forest

Perdix perdix

Kustanay: 7 October: 6 ind. at Naurzum forest and 9 October: c. 10 individuals by the roadside near Lake Koybagar
Tengiz: 3 ind.

Coturnix coturnix

Kustanay: c. 15 ind.
Tengiz: 2 ind.

Grus grus

Kustanay: 1 October: 2 ind. at Lake Kulykol, 4 October 320 migrating ind. in three flocks at Lake Ayke and 6 October: 12 ind. at Lake Batpakkol
Tengiz: c. 200 ind.

Tetrax tetrax

Kustanay: 7 ind. at Lake Kushmurun, 9 October
Tengiz: 1 ind. between Kurgaldzhino and Karazhar, 4 October

Recurvirostra avosetta

Tengiz: c. 430 ind.

Charadrius hiaticula

Kustanay: 1–2 October: 3 ind. at Lake Kulykol
Tengiz: c. 20 ind.

Charadrius morinellus

Tengiz: 1 migrating at Lake Zhylandyshalkar, 3 October

Pluvialis apricaria

Kustanay: 2 October: 1 ind. at Lake Kulykol and 11 October: 3 ind. at Lake Tyuntyugur

Pluvialis squatarola

Kustanay: c. 120 ind.
Tengiz: c. 750 ind.

Pluvialis fulva

Tengiz: 44 juv. of which 15 at Lake Uyalyshalkar, 3 October

Vanellus vanellus

Kustanay: c. 160 ind.
Tengiz: >1000 ind.

Calidris alba

Kustanay: 5 ind. at Lake Kulykol, 1–2 October
Tengiz: 1 juv. at Lake Ashi-Kumkol, 4 October

Calidris minuta

Kustanay: 1–2 October: 40 ind. at Lake Kulykol and 3 October: 10 ind. at Lake Ayke
Tengiz: c. 250 ind., mostly juv.

Calidris alpina

Kustanay: 1 October: 60 ind. at Lake Kulykol, 3 October: 1 ind. at Lake Ayke and 11 October: 1 ind. at Lake Tyuntyugur
Tengiz: c. 600 ind.

Calidris ferruginea

Tengiz: 1 juv. at Lake Sholak, 2 October

Calidris temminckii

Tengiz: 3 ind.

Undertied small wader sp. (Calidris sp.)

Kustanay: 100 ind. at Lake Kulykol, 1 October
Tengiz: some hundreds

Philomachus pugnax

Kustanay: 1–2 October: 20 ind. at Lake Kulykol, 3–4 October: 20 ind. at Lake Ayke and 11 October: 15 ind. at Lake Tyuntyugur
Tengiz: c. 300 ind.

Gallinago gallinago

Kustanay: c. 10 ind.
Tengiz: 3 ind.

Limosa limosa

Tengiz: c. 300 ind.

Limosa lapponica

Kustanay: 2 ind. at Lake Tyuntyugur, 11 October
Tengiz: 6 ind.

APPENDIX C

Table 1. Numbers of wetland birds (except for geese, for which see article on pp. 39-46) in the Kustanay region.

Lake Species	Kulykol 1 Oct	Kulykol 2 Oct	Ayke 4 Oct	Ayke 5 Oct	Batpakkol 6 Oct	Kulakol 7 Oct	Kushmurun 8-9 Oct	Koybagar 9-10 Oct	Tyuntyugur 10-11 Oct	Bozshakol 12 Oct
<i>Podiceps cristatus</i>	6		5	c.20	c.15			xx	c.250	
<i>Podiceps nigricollis</i>					6					
<i>Podiceps auritus</i>					2					
<i>Podiceps nig/aur</i>				6						
<i>Botaurus stellaris</i>					3					
<i>Egretta alba</i>	c.10	3	2	4				1	c.25	
<i>Ardea cinerea</i>			3		c.10			4	c.15	
<i>Phalacrocorax carbo</i>		1			c.20			c.10	12	c.120
<i>Cygnus olor</i>	9	c.10	8		2			xxx		
<i>Cygnus cygnus</i>	c.5		3	6	2	58	c.200		c.260	
<i>Cygnus columbianus</i>	c.20	c.10	1			90			c.10	
<i>Cygnus sp.</i>	c.30	2	c.10	5						
<i>Branta bernicla</i>	1									
<i>Tadorna tadorna</i>	c.15	20	10	4		1				
<i>Tadorna ferruginea</i>	c.400	c.400	c.550	c.1,200		1		x		
<i>Anas penelope</i>	x	xx	xx	x	c.10	c.400	xx	xxx	c.150	
<i>Anas strepera</i>	c.20				1	5		xx	c.10	
<i>Anas crecca</i>	xxx	xxx	xx	xx	c.50			xx	c.150	
<i>Anas platyrhynchos</i>	xxxx	xxxxx	xxx	xxx	c.50	c.150		xxx	c.700	
<i>Anas acuta</i>	xxxx	xxxx(x)	xxx(x)	xxx	c.30	c.40			c.50	
<i>Anas querquedula</i>		10								
<i>Anas clypeata</i>	x(x)	xxx		xx(x)	c.200	c.50		xx	c.30	
<i>Netta rufina</i>		1			7	c.10	c.20	30		
<i>Aythya ferina</i>			c.300	xxx	c.50	c.20	c.20	xxx	c.150	c.100
<i>Aythya fuligula</i>	c.100	xx	c.1,000	xxxx	c.50	c.150		xxxx	c.400	
<i>Aythya marila</i>								3		
<i>Bucephala clangula</i>	c.10	5	5	c.10	c.10	c.20		xxx	c.150	
<i>Mergus albellus</i>			9	20	c.40	c.55	c.20	xx	c.100	
<i>Mergus serrator</i>						1				
<i>Mergus mermerganser</i>							4			
<i>Fulica atra</i>	c.500		c.1,000	c.1,000	c.150			xxxx	xxx	
Waterfowl							c.1,000	>10,000	xxxxx	c.1,000

Numenius arquata

Kustanay: 11 October: 1 ind. at Lake Tyuntyugur and on 12 October: 1 ind. at Lake Bozshakol
Tengiz: 4 ind.

Tringa erythropus

Kustanay: 2 October: 1 ind. at Lake Kulykol, 6 October: 3 ind. at Lake Batpakkol and 11 October: 60 ind. at Lake Tyuntyugur
Tengiz: c. 25 ind.

Tringa nebularia

Tengiz: 1 ind.

Tringa glareola

Kustanay: 1 October: 1 ind. at Lake Kulykol

Tringa totanus

Tengiz: 3 ind.

Phalaropus lobatus

Kustanay: 5 October: 1 ind. on a small pond between lakes Ayke and Batpakkol
Tengiz: 2 juv. at Lake Zhylandyshalkar, 3 October

Stercorarius parasiticus

Tengiz: 1 juv. at Karazhar, 2 October; 1 juv. at Karazhar, 9 October

Larus ichthyæetus

Kustanay: 1 October: 2 ind. at Lake Kulykol, 6 October: 3 ind. at Lake Batpakkol and 11 October: 3 ind. at Lake Tyuntyugur
Tengiz: 18 ind.

Larus ridibundus

Kustanay & Tengiz: thousands

Larus genei

Kustanay: 1 October: 2 ind. at Lake Kulykol and 4 October: 1 ind. at Lake Ayke
Tengiz: 7 ind.

Larus canus

Kustanay & Tengiz: thousands

Larus cachinnans s.l.

Kustanay: 1-2 October: 10 ind. at Lake Kulykol, 3-4 October: 5 ind. at Lake Ayke, 6 October: 5 ind. at Lake Batpakkol and 11 October: 20 ind. at Lake Tyuntyugur
Tengiz: tens (mostly of *barabensis* type, with single ind. of *cachinnans* type)

Gelochelidon nilotica

Tengiz: 1 juv. at Lake Zhylandyshalkar, 2 October

Sterna hirundo

Tengiz: 2 juv. at Lake Sochinskoye, 7 October

Chlidonias leucopterus

Kustanay: 2 October: 1 juv at Lake Kulykol

Columba livia

Kustanay & Tengiz: common in cities and villages

Columba palumbus

Kustanay: 2 October: 2 ind. at Lake Kulykol, 6 October: 4 ind. at Lake Batpakkol and 10 October: 1 ind. at Lake Koybagar
Tengiz: 1 ind.

Columba oenas

Kustanay & Tengiz: hundreds

Streptopelia decaocto

Kustanay: some ind. in villages

Streptopelia orientalis

Kustanay: 9 October: 1 ind. at the northern part of Lake Kushmurun

Streptopelia turtur/orientalis

Kustanay: 2 October: 1 ind. at Lake Kulykol

Asio flammeus & Asio sp.

Tengiz: 11 ind., of which 8 ind. identified as *A. flammeus*

Dendrocopos major

Kustanay: 7 October: c. 10 ind. at Naurzum forest
Tengiz: 1 at Lake Zhylandyshalkar, 3 October

Melanocorypha leucoptera

Kustanay: 4 October: 1 ind. at Lake Ayke, 6 October: 1 ind. at Lake Batpakkol and 7 October: 122 ind. in two flocks at Lake Kulakol
Tengiz: c. 2500 ind.

Melanocorypha yeltoniensis

Kustanay: 1-2 October: 100 ind. at Lake Kulykol, 3-5 October: c. 7,000 ind. at Lake Ayke, 6 October: 500 ind. at Lake Batpakkol and 7 October: 12 ind. at Lake Kulakol
Tengiz: c. 5000 ind.

Alda arvensis

Kustanay: Very common in the south, scarcer in the north. Heavy migration was noticed 4-5 October at Lake Ayke when c. 10,000 individuals were moving north.
Tengiz: some thousands

APPENDIX C

Carduelis spinus

Kustanay: 7 October: 15 ind. at Naurzum forest

Carduelis flavirostris

Kustanay: 6 October: altogether c. 250 ind. were migrating in small flocks at Lake Batpakkol
Tengiz: tens

Carduelis cannabina

Tengiz: 2 ind.

Carduelis flammea

Kustanay: 6 October: 15 ind. at Lake Batpakkol

Coccothraustes

coccothraustes
Tengiz: 3 ind.

Calcarius lapponicus

Kustanay: c.100 ind.
Tengiz: c. 20 ind.

Emberiza citrinella

Kustanay: c. 90 ind.
Tengiz: c. 20 identified pure *E.*

citrinella + c. 100 unidentified *E.citrinella/leucocephala*

Emberiza leucocephala

Tengiz: 8 identified pure *E. leucocephala*, in addition <10 ind. *E.citrinella x leucocephala* hybrids

Emberiza hortulana

Kustanay: 4–5 October: 2 ind. were heard at Lake Ayke

Emberiza rustica/pusilla/aureola

Kustanay: 6 October: 1 ind. at Lake Batpakkol

Emberiza schoeniclus

Kustanay & Tengiz: hundreds

Errata

In the previous Annual report 1998 (Appendix D: Annotated checklist of bird observations during the Lesser White-fronted Goose expedition to Kustanai Region), the

following lines were dropped out:

Larus canus
thousands

Larus "heuglini"
42 ind.

Larus cachinnans
c. 200 ind.

Sterna hirundo
11 October: 2 ind. at Lake Tyuntyugur

Chlidonias niger
12 October: 1 ad at Lake Tyuntyugur

Columba livia
common

Columba oenas
c. 900 ind.

Columba palumbus
7 ind.

Streptopelia decaocto

5 October: 4 ind. at Kustanay, 10 October: 2 ind. between Docuchayevka and Koybagar

Streptopelia orientalis

8 October: 1 juv between Ayke and Batpakkol

Asio flammeus
4 ind.

Alauda arvensis
thousands

Eremophila alpestris

77 ind. of which 74 ind. at Lake Rechnoe

Melanocorypha yeltoniensis
c. 2700, biggest flock 700 ind.

Melanocorypha leucoptera
c. 450 ind.

Hirundo rustica

7 October: 1 ind. at Lake Kulykol and 1 ind. at Lake Karakul

The similarity of the Lesser White-fronted Goose (*Anser erythropus*) and the White-fronted Goose (*Anser albifrons*) is one of the main problems in the conservation of the Lesser White-fronted Goose. The identification of these two species is surprisingly difficult.

Size alone can not be used to identify the species. The head of the Lesser White-front is smaller and neater, more rounded (sometimes the head appears to be box-shaped) with a relatively bigger eye and steeper forehead than White-fronted Goose. The bill is relatively much shorter than in White-fronted Goose and almost triangular in shape. The neck of Lesser White-front is distinctly shorter and relatively thicker than in the White-front. In a flock on the ground, a good hint for sorting out a Lesser White-front is the overall darkness of the bird. In addition, Lesser White-fronts normally show a more upright posture than White-fronts. The wings of the Lesser White-front are relatively somewhat longer, reaching beyond the tail (when fully grown), but careful observation is necessary because also White-fronts can sit in a position where the wings reach beyond the tail.

Flight identification (see front cover)

In flight, the two species are very difficult to separate. The identification is easier if a direct comparison with the other species is possible. Especially single juvenile Lesser White-fronts in a flock of White-fronted Geese are extremely difficult to discover and identify.

The colouring of the wing of Lesser White-fronted Goose and White-fronted Goose is very similar. The primary coverts and the base of a few outermost primaries are quite light blue-grey in both species. Both of the species has one clearly visible white wing bar, formed by the white tips of the greater secondary coverts.

The smaller size of the Lesser White-front alone is not a good cue for flight identification, but the shorter neck and bill, and the relatively somewhat narrower wings are flight identification cues that should be paid attention to. This, combined with the shape of the head and the uniform darkness of the head and the upper neck of the Lesser White-fronted Goose are the only valuable features for flight identification.

Further information on identification:

Øien, I.J., Tolvanen, P., Aarvak, T. & Markkola, J. 1999: Occurrence and identification of Lesser White-fronted Goose. – *Alula* 5:18–23.

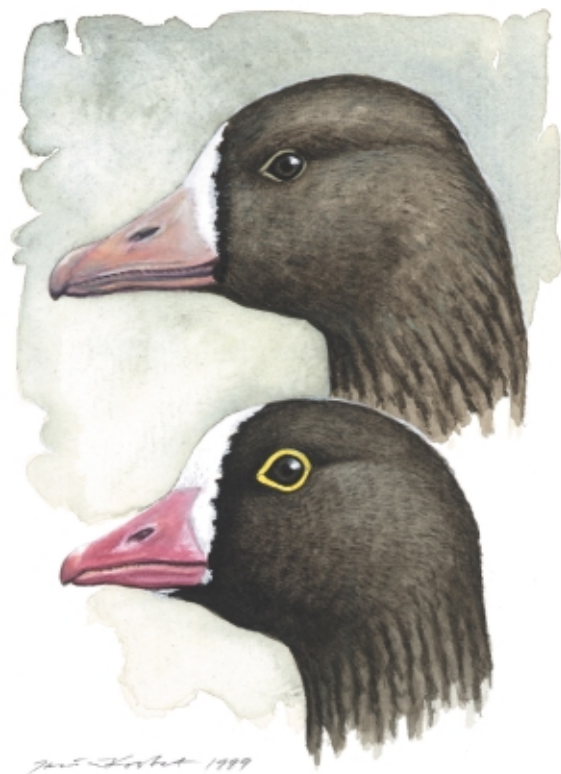

Above. The ground colour of head and neck is one of the most important and useful features to separate adult Lesser White-fronted Goose from White-fronted Goose. In the Lesser White-front, the whole head and the upper 2/3 of neck is quite uniformly dark brown, distinctly darker than in the White-fronted Goose. In the White-fronted Goose, only a narrow zone at the rear margin of the white blaze is dark brown, contrasting clearly with the light brown head and neck.

The short triangular bill of the Lesser White-front is brighter pink in colour than the bill of the White-front, and the white blaze reaches further up on crown. Both species show much variation in the size of the white blaze; some individuals (especially 2cy birds in spring) have very small white blaze and the shape of the blaze should not be used as an identification feature alone.

Even if the swollen bright-yellow eye ring of the Lesser White-fronted Goose is prominent at short distances, it is normally not visible beyond 300 metres, but exceptionally the eye-ring can be seen with a good telescope at a distance of c. 600 metres. It is also worth noting that c. 20% of White-fronts of the nominate race show a thin dull yellow eye ring.



Adult Bean Goose of taiga race
Anser fabalis fabalis



Adult White-fronted Goose
Anser albifrons albifrons



Adult Lesser White-fronted Goose
Anser erythropus